

# RADIO

## Experimenter

RADIO • TELEVISION • ELECTRONICS

A SCIENCE AND MECHANICS  
**35¢**  
PUBLICATION



*How to Build* Television Receiver • Crystal and Battery Sets • Superhet Receivers • Radio Control Home Broadcaster • Electric Eye • Intercom System • Electronic Organ • and many others

# RADIO EXPERIMENTERS' KITS

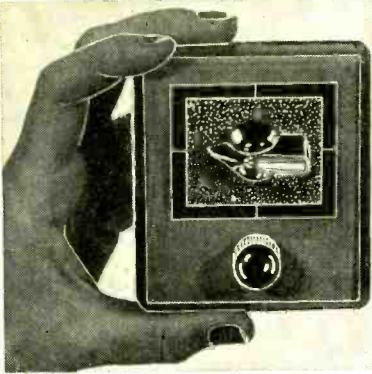

Radio-Electronics-Television are three great hobbies in one! Even if you have had no previous experience, these unique Blanchard Kits make learning lots of fun!

## SUPER-WIDGET POCKET SET

(U. S. Patent No. 2,092,069)

This hearing-aid size radio has amazing power and range. Do not confuse with any crystal gadget. This is an electronic set!

This new Pocket Model of our famous Super-Widget packs more power than even our amazing standard model described below. Yet it is so compact that miniature electron-tube and batteries fit inside the striking plastic case.

Pocket Super-Widget is only 7/8" thick—fits shirt pocket yet we have received stations 2000 miles away, and with good volume. Local stations will work loudspeaker.

No radio knowledge needed to assemble this set. Parts mounting and wiring printed on set chassis plate. Everything, including dial, protected inside streamlined case. Complete kit including miniature tube ONLY \$3.99 postpaid. (Phones & batteries extra.)

## SPECIAL ELECTRONIC KITS

**ELECTRIC EYE CONTROL.** Complete kit for building a Photo Electric Control used in Electronic Light Beam Burglar Alarms, Counters, etc. Outfit includes finished aluminum chassis, sensitive relay, resistors, amplifier tube and photo-electric cell. Operates on 115 v. AC-DC. Complete ready-to-wire kit Only \$4.95 postpaid.

**ELECTRONIC ORGAN.** Ready-to-wire kit for Organ oscillator-amplifier. (See diagram p. 49 this manual.) You receive aluminum chassis, audio transformer, terminal strip, etc. to complete the basic unit, including one tone condenser. Only \$3.75 postpaid, less tube, speaker and keyboard resistors.

**SUPER-WIDGET BROADCASTER.** Similar in design to the famous Super-Widget standard model radio. This tiny battery operated unit transmits voice or music through your home set without connections. Simply attach phono pick-up or mike and this unique electronic unit does the rest. This carrier current device is ideal for school demonstration use. Only \$2.99 postpaid including tube (batteries not included.)

**MINI-ELECTROPHONE.** Assemble your own loud-speaking radio telephone (intercommunicator) with this miniature master station unit. Ideal electronic phone for farm and home. Kit includes finished aluminum chassis and all parts except tubes and speakers which are extra. Only \$4.75 postpaid.

**ACCESSORIES.** Sensitive Double Headsets, \$1.95 pr. PM Speakers, \$1.95. Speaker Transformer, 69c. Midget Soldering Irons, \$1.59. Solder (radio type) 25c. Tubes for all kits (except "Pocket Electric") 95c each. Heavy Aluminum Boxes with cover size 5x3x2 in. only 79c. Plastic Boxes, 3x3x1 in. clear acetate, 49c. Sensitive Relays, 5000 ohms. SPST, \$1.49 ea.



## POCKET RADIO & BROADCASTER

This versatile device is actually a miniature electronic lab! Get into this fascinating hobby by assembling a real radio and transmitter yourself. Use same kit for other experiments.

This Duo-Set comes ready-to-assemble. Has sparkling gray wrinkle chassis, plus dial, knobs, socket, resistors, condensers, hardware, coil, etc., as shown here. A truly great value! Works on 115v. AC-DC. ONLY \$3.99 POSTPAID, less tubes and phones

### HOW TO ORDER

Remit by postal note, postal or express money-order, check or cash (at your risk). C.O.D. orders must include \$1.00 deposit. School and institution orders filled on "open account" if sent on official Purchase Order.

## SUPER-WIDGET

(U. S. Patent No. 2,092,069)

## RADIO SET \$2.99

Twenty times more powerful than best crystal set. Louder than many sets with several tubes. Highly selective. Works anywhere on two inexpensive batteries.

This new Blanchard design is a home! Complete kit, including tube as shown, only \$2.99, postpaid anywhere. (Phone and batteries extra.) Picture plans included



## THE ORIGINAL AND GENUINE ALL-WAVE MINI-BATTERY SET

Tiny as king-size cigarettes. Electro-Mite works on penlite or hear-aid cells. Amazing Power! Coast-to-coast results obtained. Not a toy, gadget, or surplus! New & improved circuit. Thousands of pleased users. Complete kit. Add 25c for postage. Tubes extra 95c each.

ONLY \$2.99



## 3 in 1 ELECTRONIC SET

Radio • Electric Eye • Broadcaster

Complete kit builds this all-electric 2-tube radio. Everything furnished, ready to wire as shown! Easily converted into Electric Eye and Home Broadcaster at slight extra cost. Nothing like this available anywhere at three times the price! Brilliant rod steel chassis with new streamlined dial & bakelite knobs. Set also receives domestic & foreign shortwave stations as explained with kit. Order now @ \$3.99 (including postage packing tubes 95c ea.



## ULTRA-GEM SCHOOL SET

We have long realized the need for a really low-cost students radio for group project use. Until now, however, it was impossible to pare down costs to a point where a really sensitive and powerful electron-tube radio could be offered at less than a feeble and crude crystal set would cost.

The Ultra-Gem employs our unique "Super-Widget" circuit (U.S. Patent # 2,092,069) plus ultra-simplified components designs (Pat. Applied For) that make this set a fascinating student project in Manual Training, Physics, and Therapeutic classes.

**ATTENTION TEACHERS!** The Ultra-Gem described above is furnished in minimum quantities of 10 kits at only 99c each, including an individual instruction sheet with each kit. This price, of course does not include miniature tube, phone, or batteries. However a special tube offer is included with kits.

## E. G. LITTLE, Mfrs.

BLANCHARD ELECTRONIC PRODUCTS  
SPRINGDALE 11, CONNECTICUT





*I Will Show You How to*  
**LEARN RADIO**  
 Servicing or Communications  
*by Practicing in Spare Time*

*I Send You  
 Many Kits of  
 Radio Parts*

**YOU PRACTICE RADIO SERVICING**

You build the modern Radio shown below as part of my Servicing Course. I send you the speaker, tubes, chassis, transformer, loop antenna, EVERYTHING you need to build this modern Radio Receiver. Use it to make many tests, get practical experience.

**YOU PRACTICE RADIO COMMUNICATIONS**

I send you parts to build the Transmitter shown below as part of my new Communications Course. Conduct actual procedure of Broadcast Station Operators, practice interesting experiments, learn how to put a transmitter on the air.

**NEW**

**YOU BUILD THIS TESTER**

as part of my Servicing Course. It soon helps you EARN EXTRA MONEY fixing neighbors' Radios in spare time.

**BUILD THIS WAVEMETER**

as part of my NEW Communications Course. Use it with Oscillator you also build that furnishes basic power to transmitter and determines transmitter frequency.

**I TRAINED THESE MEN**

HAS GOOD JOB IN RADIO STATION "Am Chief Engineer of Radio Station WORD in charge of 4 men. Owe all I know about Radio to NRI."  
 —CLYDE J. BURDETTE, Spartanburg, South Carolina.

HAS HIS OWN RADIO BUSINESS "Now have two Radio shops servicing about 200 sets a month. Have largest service establishment in South-eastern Missouri."  
 —ARLEY STUDYVIN, DeSoto, Missouri.

**KNOW RADIO • Win Success**  
**I Will Train You at Home • SAMPLE LESSON FREE**

Want a good-pay job in the fast-growing Radio and Television Industries, or your own money-making Radio-Television shop? I've trained hundreds of men WITH NO PREVIOUS TRAINING to be Radio technicians. I can do the same for you. Or now you can enroll in my NEW practical course in Radio-Television COMMUNICATIONS—learn to be a Broadcasting and Communications technician. You get practical Radio experience with MANY KITS OF PARTS I send you in my train-at-home method. All equipment yours to keep.

**Make Extra Money In Spare Time**  
 As part of my Radio Servicing Course, I send EXTRA MONEY booklets starting the day you enroll. Make extra money fixing Radios in spare time while training. Then start your own Radio sales and service shop

or get a good-pay job in Government, Police, Aviation or Marine Radio, Broadcasting, Public Address work, etc. Or think of amazing Television opportunities. Already manufacturers are producing over 100,000 sets a month. New stations going on the air everywhere! Television is America's fastest-growing industry and men who know it will be in demand.

**Get Actual Lesson And Book Free**  
 My DOUBLE FREE OFFER entitles you to actual SAMPLE LESSON and my 64-page book, "HOW TO BE A SUCCESS IN RADIO—TELEVISION—ELECTRONICS," both FREE. Mail coupon now. See how quickly, easily you can start. J. E. SMITH, President, Dept. 9KT, National Radio Institute, Pioneer Home Study Radio School, Washington 9, D. C.

**VETERANS**  
 Get This Training Without Cost Under G. I. Bill

**Good for Both—FREE**

- MR. J. E. SMITH, Pres., Dept. 9KT National Radio Institute, Washington 9, D. C.
- Mail me FREE Lesson and 64-page book. (No salesman will call. Please write plainly.)

GETTING ACQUAINTED WITH RECEIVER SERVICING

How to Be a Success in RADIO TELEVISION ELECTRONICS

MY COURSE INCLUDES **TELEVISION**

NAME..... AGE.....

ADDRESS.....

CITY..... ZONE..... STATE.....

Check If Veteran APPROVED FOR TRAINING UNDER G. I. BILL

# RADIO

## *Experimenter*

**RADIO • TELEVISION • ELECTRONICS**

**V. D. ANGERMAN**  
Editor and Publisher

**DON DINWIDDIE**  
Managing Editor

**PAT D. URBAIN**  
Associate Editor

**L. G. ANDERSEN**  
Assistant Editor

---



---

### CONTENTS

---



---

Modern Television Receiver . . . . .	5	Mini-Battery Set . . . . .	79
Pee Wee Oscillator . . . . .	22	Electronic Duo-Set . . . . .	82
Dial a Tune Radio . . . . .	24	Fixed Detector Crystal Set . . . . .	85
FM Converter and Pocket Radio . . . . .	27	"Ocean Hopper" Receiver . . . . .	87
Super Power Midget . . . . .	28	Tapped Coil Crystal Set . . . . .	91
Single Tube Amplifier . . . . .	33	Replacing Filter Condensers . . . . .	94
Precision Electronic Timer . . . . .	36	Electronics Made Easy . . . . .	98
20-Minute Mike . . . . .	39	Radio Control for Models . . . . .	103
Loudspeaker Crystal Receiver . . . . .	40	Portable Di-Poles for TV and FM . . . . .	115
Twin-Lead Standoff Insulators . . . . .	42	Miniature Power Supply . . . . .	118
Home Broadcaster . . . . .	43	Home Built Record Player . . . . .	121
Electronic Timer . . . . .	46	Phonograph-Radio Combination . . . . .	127
Electronic Organ . . . . .	48	Surplus Headphones . . . . .	130
Three-in-One Electronic Set . . . . .	52	Toy Bank Crystal Set . . . . .	134
Portable Superhet . . . . .	61	Speed Control for Record Players . . . . .	137
Multi-Purpose Sound System . . . . .	64	Constructing a 4 Tube TRF Receiver . . . . .	140
Alarm Clock Time Switch . . . . .	66	Modern Crystal Radio Receiver . . . . .	144
Listen-Ear—A Real Radio Aid . . . . .	68	For Your Radio Notebook . . . . .	136
Tele-Tenna . . . . .	70	How to Get Three Speeds from a Two-Speed Phono Motor . . . . .	147
Converting Table Radio into Radio Phono . . . . .	74	Radio and Electrical Soldering . . . . .	148
Two Tube Intercom . . . . .	76		

Published and Copyright 1949 by  
SCIENCE AND MECHANICS PUBLISHING COMPANY  
450 East Ohio Street, Chicago 11, Ill.





**SENSATIONAL**



**A NEW  
D. T. I.  
TRAINING  
FEATURE**

**New Training Offer!**

**NOW you build and keep a top quality**

**TELEVISION**

**RECEIVER**

to help you prepare for a real job in

**TELEVISION  
RADIO-ELECTRONICS**

**Choice of 10, 12 or 16 INCH TELEVISION PICTURE TUBE**

Now you can get this amazingly practical aid for learning Television at home, to help you get started toward **FASCINATING WORK... GOOD MONEY... a THRILLING FUTURE** — in a real job, or your own sales and service business. • When you complete our regular home training — described below — you can build and keep a top quality commercial-type Television Receiver. Standardized chassis is adaptable for a 10, 12 or 16 inch direct view tube that gives big, bright, sharp, steady pictures. This is an optional training advantage — designed to provide the utmost in practical "learn-by-doing" home training in Television. Mail coupon for complete details. See why you owe it to your "Television Future" to enroll for DeForest's Training, Inc.

**Mail Coupon NOW for FREE Information!**

See how D. T. I.'s amazingly effective methods help start you toward a **GOOD JOB** or your **OWN BUSINESS** in one of America's most promising fields — including Television, F. M. Radio, Aviation, Train, and Taxi Radio, Broadcast Radio, Industrial Electronics. Get modern lessons... plus 16 shipments of Radio-Electronic parts. Work over 300 experiments and projects — including building of (1) commercial-type **OSCILLOSCOPE** for practical T-V circuit training, (2) double-range **R-F SIGNAL GENERATOR**, (3) jewel-bearing **MULTIMETER**, (4) quality 6-tube **SUPERHET RADIO**. Then build and keep that big new Television Receiver. Here's **EVERYTHING YOU NEED** for real laboratory-type training... **AT HOME!**



**YOU ALSO BUILD AND KEEP THIS PROFESSIONAL TYPE EQUIPMENT!**

**Modern Chicago Laboratories**

★ If you prefer, you can get **ALL** your preparation in our new, Chicago training laboratories... one of the finest of its kind. Ample instructors... modern equipment. Write for details!

**Employment Service**

★ When you complete your training, our effective Employment Service helps you get started toward a real future in Television — Radio — Electronics.

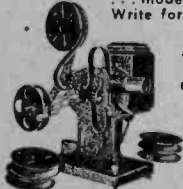

**You also use HOME MOVIES!**

• **D. T. I. Exclusive!**  
D. T. I. alone includes the modern, visual training aid... **MOVIES**... to help you learn faster, easier at home. See electrons on the march and other fascinating "hidden action" — a remarkable home training advantage that speeds your progress.

**MAIL THIS COUPON TODAY!**

**DeFOREST'S TRAINING, INC.**  
2533 North Ashland Avenue, Dept. EM-F10  
Chicago 14, Illinois

Without obligation, give me complete facts showing how I may make my start in Television-Radio-Electronics.

Name \_\_\_\_\_ Age \_\_\_\_\_  
Street \_\_\_\_\_ Apt \_\_\_\_\_  
City \_\_\_\_\_ Zone \_\_\_\_\_ State \_\_\_\_\_

**De FOREST'S TRAINING, INC.**  
CHICAGO 14, ILLINOIS  
**A DE VRY Institution**

# Subscribe NOW!

## NEXT 12 ISSUES \$2.00

To introduce **SCIENCE AND MECHANICS** to new friends, we will send the next 12 issues of our big 224-page magazine for only \$2.00. Or, if you wish to take advantage of our special long term offer, we will enter your subscription for the next 24 issues for only \$3.50. If purchased individually at the single copy price of 20c each, 24 issues would cost \$4.80. Hence by accepting this offer, you save \$1.30. It's a bargain you will want to accept immediately. Clip and fill-in the coupon with your name and address, indicate the offer you accept, and mail with your remittance NOW!

### All the Latest Developments In Science and Industry

Reading **SCIENCE AND MECHANICS** is just like making a personal visit to hundreds of America's greatest manufacturing plants, for our editors take you behind the scenes and tell you about all the new developments taking place in the fields of science, mechanics and inventions all over the world. You get the news *while it is news!*

Not only does **SCIENCE AND MECHANICS** bring you the latest scientific and mechanical developments, but there are special departments to fit your individual needs. For example, there's our "how-to-do-it" department, crammed with plans and instructions for building scores of practical things in your home workshop—furniture, boats, toys,

games, tables, wall shelves, bird houses, plastic jewelry and novelties, leathercraft projects, lawn furniture, model gas engines, ship models, and many, many other useful things.

Other special departments cover radio and electronics, patents and inventions, modelcraft, electricity, photography, plastics, home planning and repairs, aviation, reviews of the latest technical and scientific books, "What's New," giving advance information about the newest materials, methods, processes and products of industry.

You'll say **SCIENCE AND MECHANICS** is the most interesting publication you have ever read. Subscribe today!

### Tells You --

- How to do all types of wood finishing
- How to build small boats
- How to install electric door openers
- How to repair electric refrigerators
- How to thaw frozen pipes
- How to make a good patent disclosure
- How to finance an invention
- How to do your own metal casting
- How to plan your future home
- How to do brazing
- How to build radio receivers
- How to build outdoor fireplaces
- How to make art metal novelties
- How to build model gas engines
- How to use radio control for models
- How to work with plastics
- How to make your own photo equipment
- How to service and rebuild small motors
- How to do plumbing jobs
- How to repair old clocks
- How to make reproductions of Early American Furniture
- How to refinish antiques
- How to install electrical outlets

### Mail This Coupon NOW!

Just clip the coupon and mail it NOW with your name, address and remittance. We'll start your subscription immediately. If, after reading your first copy you're not delighted, just tell us to cancel your subscription and we'll refund your money in full. Could any offer be fairer?

#### SCIENCE AND MECHANICS MAGAZINE

450 East Ohio Street, Dept. R-3, Chicago 11, Ill.

I want to give **SCIENCE AND MECHANICS** a trial. So enter my subscription for the period checked below for which I am enclosing my remittance.

12 ISSUES—\$2.00  
(Canada and Foreign, \$2.50)

24 ISSUES—\$3.50  
(Canada and Foreign, \$4.50)

NAME .....

ADDRESS .....

CITY ..... ZONE ..... STATE .....

OCCUPATION .....



# Modern TELEVISION RECEIVER

That modern television receiver you have been wanting so long can now be yours if you follow the instructions given in this three-part article. This fine-looking, low-cost set with its up-to-date cabinet was designed especially for our readers

Craft Print No. 35

By ADOLPH SUCHY

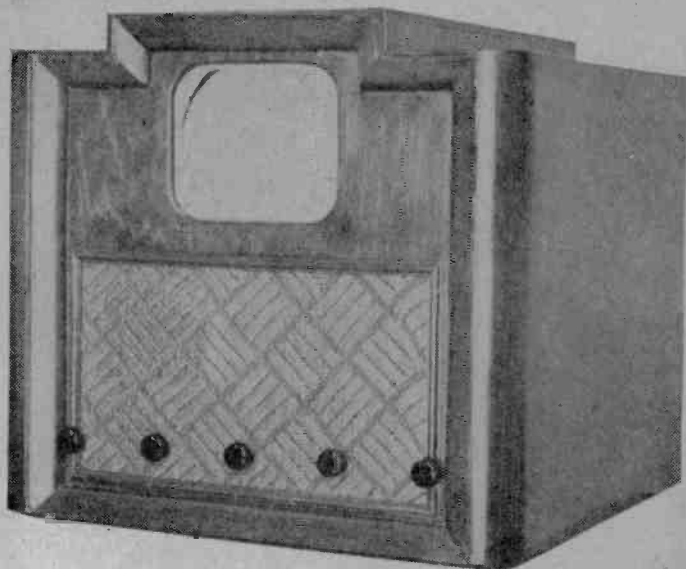

WITH the advent of modern high-fidelity television reception many requests have been received for an article on the construction, installation, and adjustment of a television receiver. Although at first glance the set and diagram described here may seem complex, the method of approach in this article simplifies it sufficiently so that anyone who has had some experience in constructing super-heterodyne receivers can easily turn out a satisfactory job. While a complete schematic diagram is given, it is used for reference only. It will enable the constructor to see how the various circuits which comprise the entire set are connected together to form the receiving system.

Set construction is divided into the following steps: First, chassis layout and mounting of parts; Second, high voltage and filament supply wiring; Third, oscillator and mixer stages—wiring; Fourth, video I. F. amplifier wiring; Fifth, horizontal oscillator and amplifier wiring; Sixth, vertical oscillator and am-

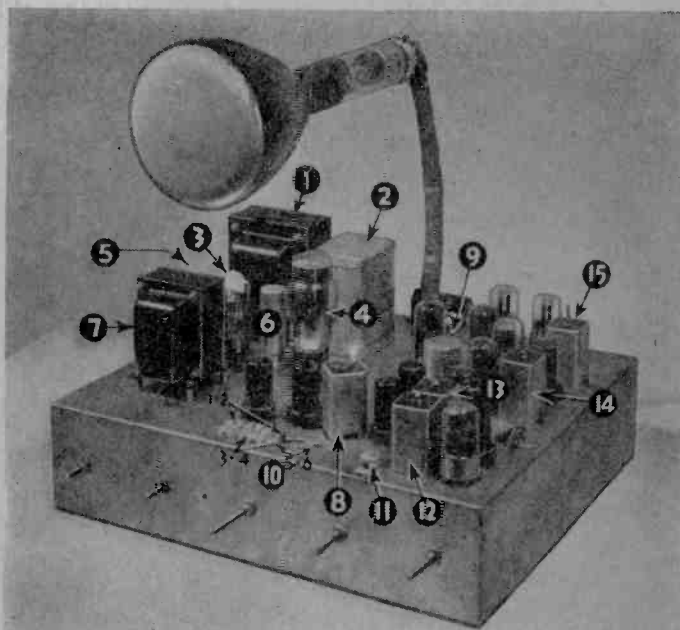

Receiver completed but not installed in cabinet. (1) L.V. power transformer; (2) L.V. choke; (3) H.V. rectifier tube; (4) L.V. rectifier tube; (5) H.V. filter condenser; (25 mid-2500v.) (6) dual section L.V. filter condenser (10-30mfd, 15-60mfd, 450 W.V.); (7) H.V. power transformer; (8) mixer I.F.; (9) L.V. filter condenser (10-10-10-10 mfd, 400 W.V.); (10) mica trimmers 162, 364 566; (11) sound sensitivity trimmer; (12) sound I.F. transformer; (13) 2nd video I.F. transformer; (14) 3rd video I.F. transformer; (15) 4th video I.F. transformer.





is completed, detailed alignment and installation procedure will be explained. In addition to receiver construction, the making of a cabinet will be described, thereby giving the builder a complete receiver, ready for installation and operation in the home. Cost of construction will vary with the parts purchased. However, if judicious use of surplus transformers and parts is made, the cost, exclusive of tubes, will be about 75 dollars. The set will accommodate either a 5 or 7 in. cathode ray tube. A 5 in. tube gives the viewer about 15 sq. in. of viewing; the 7 in. tube increases this viewing area to approximately 25 sq. in. The 5 in. tube, a 5BP4, is available on the surplus market for about \$5.00. Others have different color screens, so only a 5BP4 should be used. The 7 in. tube, a 7EP4, is not available on surplus; it costs about \$20.00. As this article is being written a new 10-in. tube is being perfected and will be available in a short time. Direct replacement of this new tube in the set with a few minor changes will make this set give about 50 sq. in. of viewing surface.

The chassis is shown in Fig. 1; front and rear aprons are shown in Fig. 2. While size of transformer holes may vary somewhat with the transformer chosen, the rest of the chassis is standard. After layout has been made on the chassis with a paper template, all round holes  $\frac{3}{8}$  in. dia. or larger are center-punched and first drilled with a No. 27 drill, then drilled with a  $\frac{3}{8}$  in. drill, and punched with a Greenlee socket punch of the proper size. The one elongated hole with  $\frac{3}{8}$  in. dia. ends may be made following the same procedure but making hole on each end and removing remainder in center with chisel and file. The square and rectangular transformer holes are made by drilling small holes around the square to be punched and, after the center has dropped out, using a file to even off the sides. Mounting of parts is shown in Fig. 3.

When the chassis was first designed, hand wound coils were used. After sleepless nights

designing, adjusting and revamping these coils (which performed fairly well when once adjusted) it was decided that manufactured coils and R. F. assembly would be easier to use. There are several manufactured television I. F. transformers and "front ends," which, when tried on this television set, proved very satisfactory and rendered high fidelity television reception.

In mounting parts particular attention should be given to the position of the keyway on each of the sockets. They are so positioned as to give the shortest possible leads. The vertical and horizontal positioning controls, which are located on the rear apron of

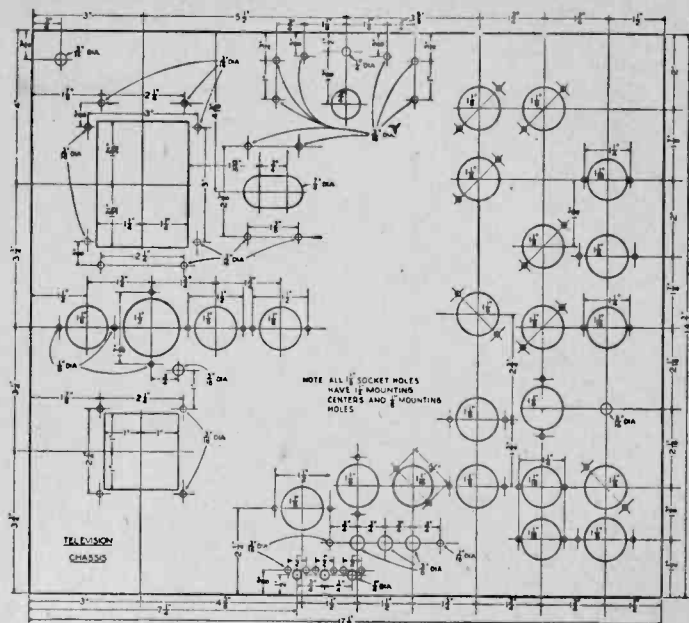

FIG. 1

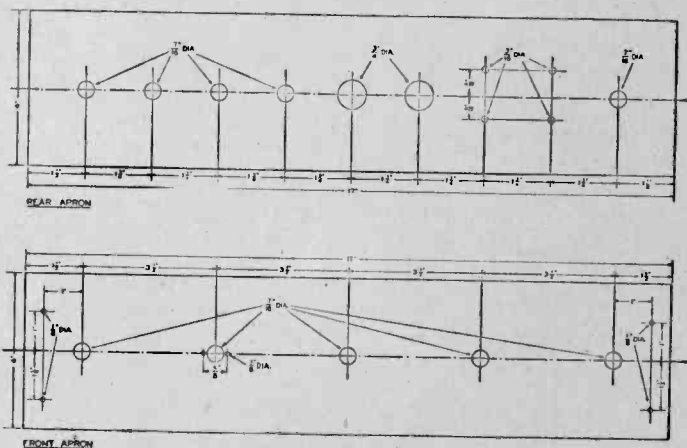
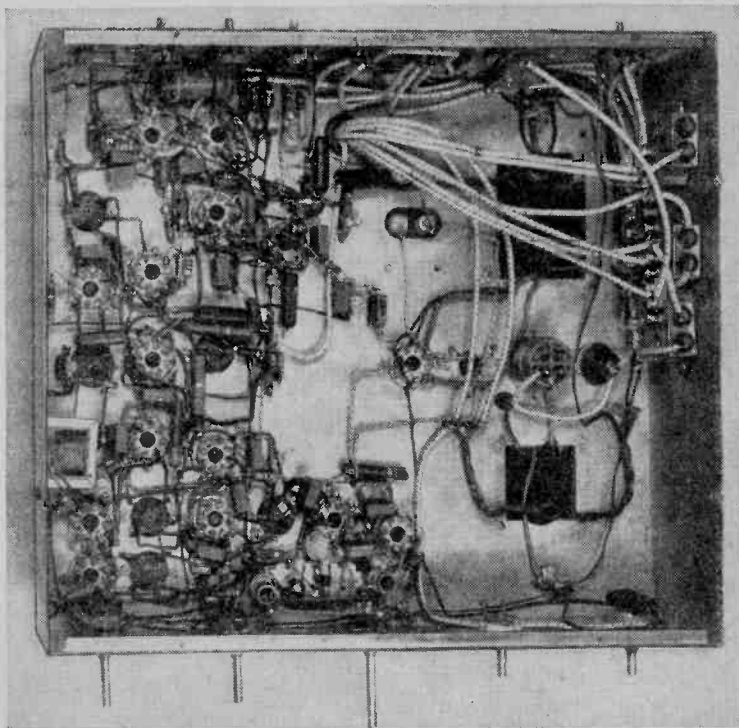

FIG. 2



Underneath view of the chassis with all the component parts installed and connections completed.

the chassis (4th and 5th controls from the left looking at the bottom of the chassis), are insulated from the chassis by fiber washers. This is to protect them from high voltage short circuit which may jump across the small gap inside the control. Grommets are used wherever wires pass through the chassis in order to eliminate wearing of the insulation and consequent short circuit. A liberal use of insulated tie lugs is highly recommended. These tie lugs serve admirably to support resistors and offer good insulation for

#### MATERIALS LIST — TELEVISION RECEIVER

- 1—chassis, drilled and punched as per Fig. 1
- 1—5BP4 (5-in.) or 1 7EP4 (7-in.) cathode ray tube
- 15 octal sockets (ceramic)
- 1—11 prong Magnal socket
- 1—4 prong recessed socket
- 1—high voltage power transformer—
  - 1800-2500 volts—2 milliamperes
  - 2.5 volts  $1\frac{1}{2}$  to 2 amperes
  - 6.3 volts 2 or more amperes
  - 110-120 volt 60 cycle primary
- 1—low voltage power transformer—
  - 700 volts 200 milliamperes
  - 5.0 volts 3 amperes
  - \*6.3 volts 9 amperes
  - 110 volts 60 cycle primary
- 1—8-10 henry 200 milliamperes choke
- 1 set I. F. transformers, peaking coils and R. F. assembly.
- 1—6" PM dynamic speaker with 6V6 output transformer
- 1—6' line cord with plug
- 1—10 henry 200 milliamperes power supply choke
- 1—antenna ground connection strip
- 1—terminal board
- 1—4 point insulated tie lug
- 24—2 point insulated tie lugs
- Rubber grommets

#### Resistors

- |                                     |             |              |
|-------------------------------------|-------------|--------------|
| $\frac{1}{2}$ or $\frac{1}{4}$ watt |             |              |
| 2—100 ohms                          | 4—5K ohms   | 7—100 K ohms |
| 2—220 ohms                          | 3—10K ohms  | 3—250K ohms  |
| 3—500 ohms                          | 1—25 K ohms | 7—500K mag.  |
| 4—2.2K ohms                         | 12—50K ohms | 4—1 megohm   |
| 4—3K ohms                           | 1—68K ohms  | 7—2 megohm   |
|                                     |             | 3—5 megohm   |

\*If necessary, use separate filament transformer for 9 ampere current.

#### Volume controls (variable resistors)

- 1—500K ohm with switch
- 1—25K ohm
- 2—100K ohm
- 5—1 megohm

#### Condensers

##### Trimmers

- 3—3-30 mmf. mica trimmers
- 4—5-40 mmf. Ceramic trimmers
- 1—15 mmf. midget variable condenser

##### Mica fixed condensers—500 volts unless specified

- 1—22 mmf.
- 1—25 mmf.
- 1—50 mmf.
- 1—125 mmf.
- 1—240 mmf.
- 2—500 mmf.
- 18— .006 mfd.
- 4— .001 mfd.
- 2— .003 mfd. 2500 volt working

##### Paper condensers (400 or 600 working volts unless specified)

- 4— .01 mfd.
- 6— .1 mfd.
- 1— .25 mfd.
- 3— .1 mfd. 2000 working volts
- 1— .25 mfd. 2500 working volts

##### Electrolytic condensers

- 1—10 mfd. 25 working volts
- 1—four section 10 mfd. 450 working volts
- 1—dual 10 mfd. 450 working volts

Condensers of higher working volt rating may be used with no difference in performance. Do NOT substitute condensers which vary more than 10% from the specified capacity.



high voltage distribution points. The terminal board situated on the right hand side of the chassis (bottom view) serves as a support for resistors and condensers.

Parts are mounted and wired on terminal strip (Fig. 3). For convenience of construction, terminals are numbered. Along with various power transformer color codes (these may vary with the make of transformer purchased) each transformer will have a color code and a drawing of the coils of both antenna and oscillator included in the box in which it is packaged. In the drawings,

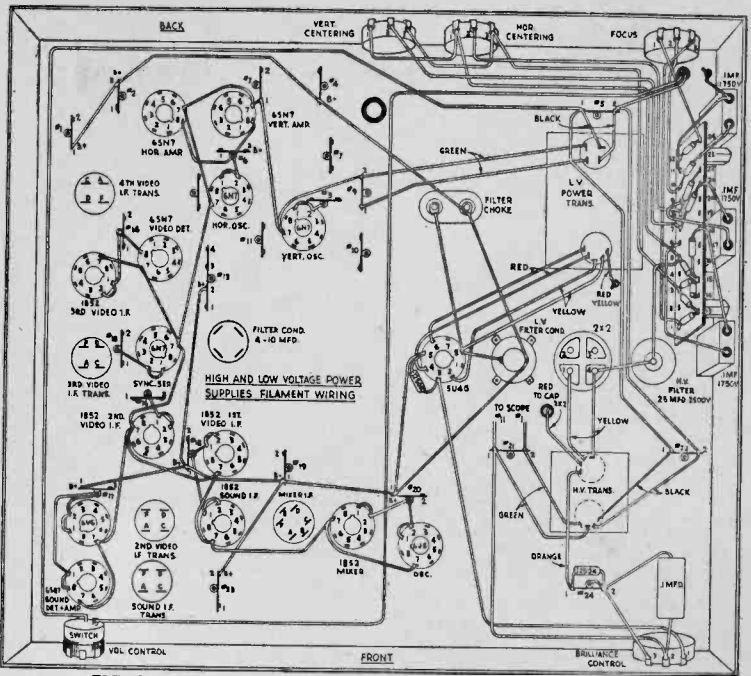

FIG. 3

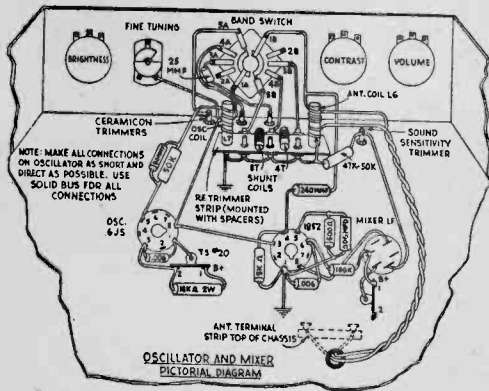

FIG. 4

Figures 3 and 3A, are pictorial and schematic diagrams for the power circuits. Because of the high voltage in the cathode ray tube circuits, special wire having a high voltage insulation must be used.

**WARNING:** The cathode ray tube circuits are high voltage and should never be worked on when the set is alive. These circuits should never be tested except by resistance analysis when the set is turned off. Never place your fingers near any of these circuits with the plug inserted in the wall or any other socket.

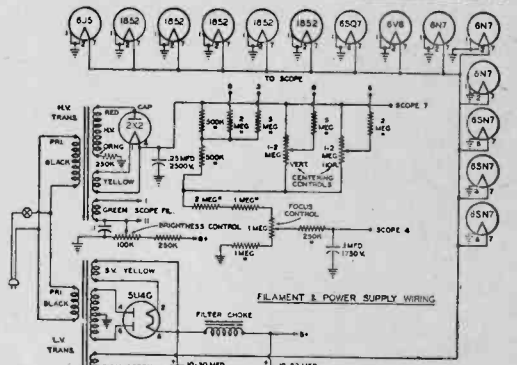

FIG. 3A

NOTE: MAKE ALL OSCILLATOR CONNECTIONS AS SHORT AND DIRECT AS POSSIBLE. USE SOLID BUS WIRE.

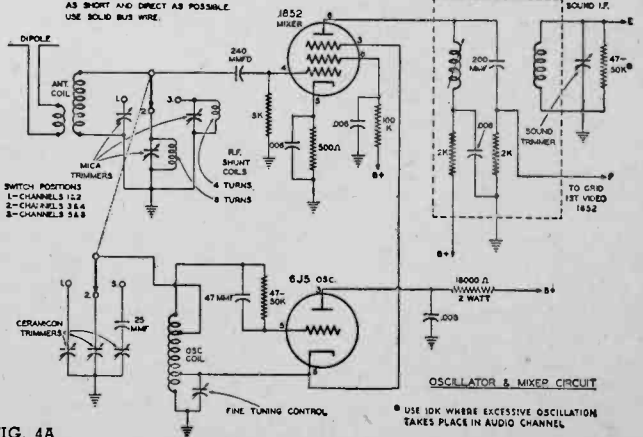

FIG. 4A









enlisted for a small fee. Testing and alignment of any television receiver will determine the performance of the set. Use the resistance analysis chart shown in Table A. All resistance measurements shown on the chart are made by placing ohmmeter between designated points of socket prongs to ground. Measurements are made with all the controls at maximum positions (full clockwise). These readings may vary plus or minus 20%. If readings obtained do not agree with the ones in the chart, check back thoroughly along circuit being tested. *Do not attempt to plug set into wall socket if readings deviate appreciably from ones specified.*

After a resistance analysis is made that agrees with the one specified, a voltage analysis is in order. All tubes except the 2X2 high voltage rectifier should be inserted in their respective sockets. **CAUTION:** *Tape the lead to the cap of the 2X2 and do not attempt to make any measurements in the high voltage circuits. Sufficient voltage and current are present to be LETHAL.* If the resistance measurements are correct, the voltage will be correct. Table B gives a chart to follow for voltage analysis. The readings were all taken on a 1000 ohm per volt meter which is the usual one that a radio experimenter or radio service man has available. When making these measurements the contrast and volume controls are set at minimum. Permissible variation is 25% in these readings. Should the variation be greater than this, make a thorough check to determine the trouble.

Alignment of set is an important and detailed matter and the job can be done with a signal generator of the type usually used for radio receiver alignment. This generator should supply a modulated signal at 8.25 megacycles and 12.75 megacycles. While it is desirable to have a high

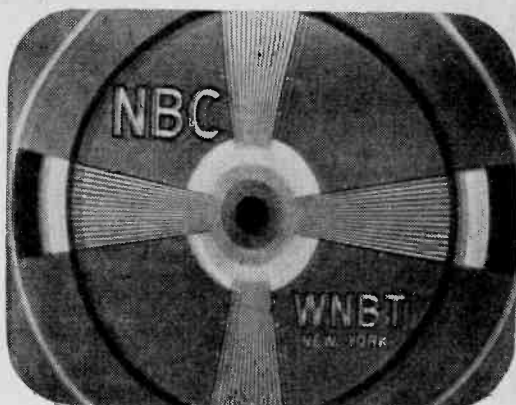

Ghost images, probably due to reflections from surrounding buildings, can be cured by reorienting antenna.

frequency signal generator, it is not absolutely necessary to have it to align the set properly. Here again it may be necessary to call upon the local radio man for assistance as he has this equipment and knows how to use it properly.

The first operation is to align the sound I. F. section of the receiver to 8.25 megacycles. Set the signal generator to that frequency and turn the modulation in the signal generator on. Then remove 6J5 local oscillator in the set from its socket. Now connect hot lead from signal generator to input grid of mixer tube [No. 4 pin of the 6AC7/1852 mixer]. With volume control on full, adjust screw that protrudes from sound I. F. coil can for maximum output from speaker. As screw is adjusted, sound will increase in intensity till a peak is reached; then sound will decrease in intensity. Pass the peak and return to it by reversing the direction of turning. In all

TELEVISION STATIONS IN THE UNITED STATES

City	Call Letters	Channel No.	Commencement Date	City	Call Letters	Channel No.	Commencement Date	City	Call Letters	Channel No.	Commencement Date
Birmingham, Ala.	WBRC-TV	4	CP*	New Orleans, La.	WDSU-TV	6	12/18/48	Columbus, Ohio.	WLWC	3	CP*
Phoenix, Ariz.	KTLX	5	CP*	New Orleans	WRTV	4	CP*	Columbus	WTVN	6	3/49
Hollywood 28, Cal.	KNBH	4	1/49	Boston 34, Mass.	WMAR-TV	2	10/30/47	Dayton	WLWD	5	CP*
Hollywood 38	KTLA	5	9/42	Boston 34	WBZ-TV	4	5/29/48	Oklahoma City,			Summer
Hollywood 28	KTSL	2	12/23/31	Waltham	WRTB	2	CP*	Okl.	WKY-TV	4	1949
Riverside	KARO	1 or 6	CP*	Detroit, Mich.	WJBK-TV	2	10/24/48	Tulsa	KOVH	6	CP*
San Francisco	KCPR	4	CP*	Detroit	WWJ-TV	4	3/4/47	Portland, Oregon	KGWG	6	CP*
San Francisco	KPIX	5	12/1/48	Lansing	WJIM-TV	6	CP*	Portland	KTVU	3	CP*
New Haven, Conn.	WNHC-TV	6	6/48	Mpls.-St. Paul,				Lancaster, Penn.	WGAL-TV	4	3/49
Washington 5,				Minn.	KSTP-TV	5	4/23/48	Philadelphia	WFIL-TV	6	9/13/47
D. C.	WNBW	4	6/27/47	Mpls.-St. Paul	WTCN-TV	4	CP*	Philadelphia	WPTZ	3	1939
Washington	WTTG	5	5/45	Kansas City, Mo.	WDAF-TV	4	CP*	Philadelphia	WDTV	3	1/11/49
Jacksonville, Fla.	WMBR-TV	4	1/50	St. Louis	KSD-TV	5	2/8/47	Memphis, Tenn.	WMCT	4	CP*
Jacksonville	WJAX-TV	2	CP*	Omaha, Nebr.	WOW-TV	6	CP*	Nashville	WSM-TV	4	1949
Jacksonville	WPDO-TV	6	CP*	Omaha	KMA-TV	3	CP*	Dallas, Texas	KRLD-TV	4	1949
Miami	WTVJ	4	CP*	Trenton, N. J.		1	CP*	Forth Worth	WBAP-TV	5	9/29/43
Atlanta, Ga.	WAGA-TV	5	CP*	Albuquerque, N.M.	KOB-TV	4	1948	Houston, Tex.	KLEE-TV	2	1/1/49
Atlanta	WCNN-TV	2	CP*	Buffalo 2, N. Y.	WBEN-TV	4	5/14/48	San Antonio	KEYL	5	CP*
Chicago 1, Ill.	WBKB	4	1/6/41	New York City	WBBD	5	1941	San Antonio	WOAI-TV	4	CP*
Chicago	WNBO	5	11/1/48	New York City	WCBS-TV	2	5/5/41	Salt Lake City, U.	KDYL-TV	4	4/19/48
Chicago	WMBD-TV	6	CP*	New York City	WNBT	4	7/1/40	Salt Lake City	KSL-TV	5	CP*
Rock Island	WHBF-TV	6	CP*	Rochester	WHTM	6	CP*	Norfolk, Va.	WTAR-TV	4	CP*
Indianapolis, Ind.	WFVM-TV	6	3/49	Schenectady	WRGB	4	1939	Richmond	WTVR	6	4/22/43
Indianapolis 9	WUTV	3	Spring,	Syracuse	WSYR-TV	5	CP*	Seattle, Wash.	KRSC-TV	5	11/25/48
			1949	Charlotte, N. C.	WBT-TV	3	CP*	Huntington, W. Va.	WSAZ-TV	5	CP*
Ames, Iowa	WOI-TV	4	1949	Cincinnati, Ohio	WLWT	4	2/9/48	Milwaukee, Wis.	WTMJ-TV	3	12/3/47
Davenport, Iowa.	WOC-TV	5	CP*	Cleveland	WEWS	5	12/17/47				
Louisville, Ky.	WAVE-TV	5	11/24/48	Cleveland	WNBK	4	10/31/48				

Courtesy Broadcasting Magazine  
CP—Construction Permit

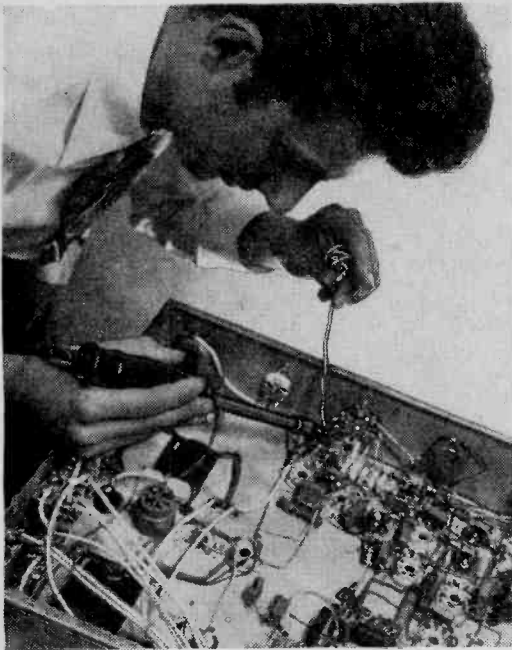

Wiring the oscillator circuit, a step which is completed during the original construction of the television receiver.

alignment, do not use an ordinary screw driver as this will add capacity to the circuit and throw the alignment off. A piece of bakelite rod ground down to simulate a screw driver will do the trick quite well. The final operation in aligning the sound I. F. is to adjust the Ceramicon sound sensitivity trimmer for maximum output. This trimmer is located next to the sound I. F. coil.

Note that the sound I. F. alignment was accomplished with 2X2 rectifier and cathode ray tube out of their sockets. Do not take the cathode ray tube from the container in which it is packed until you have reached this point. This tube has a large surface area and the danger of breakage and implosion is great. Handle cathode ray tube with extreme care and do not allow it to be jarred or struck with anything. After removing it from the packing box cut the top and bottom of the packing box off with a knife. Slip the tube back into the box. This will act as a sleeve for the tube and prevent possible accidents. Connect the magnal socket to the tube and insert the 2X2 rectifier into its socket. The set is now ready for further alignment.

As the set is turned on the raster should appear on the face of the cathode ray tube. This raster is a white oblong and can be adjusted as to size and position. At this point test the various controls that affect the raster. By adjusting horizontal height control, size of raster is varied horizontally. Size is set so that four corners of oblong just touch circumference of tube. The vertical height control is adjusted in a similar manner but affects the vertical height of the raster. The positioning controls are now rotated. These controls tend to center the raster both vertically and horizontally. Should any of these controls not operate properly, a thorough check of the circuits associated with them should be made.

The next operation is to align the video I. F. Set the signal generator to 12.75 megacycles and leave the modulation on. Leave the output leads from the generator connected to the same point as they were for aligning the sound I. F. Now adjust the screws on the several video I. F. trans-

formers for maximum peak. This may be determined by appearance of pattern on cathode ray tube. Heavy black and white lines will appear across the face of the tube. As the screws are turned the number of heavy black lines will decrease and the definition of the lines will become greater. The black lines will become blacker and the white line more brilliant. When properly aligned three heavy black horizontal lines will appear across the face of the tube. As the resonant point is passed the number of black lines will increase and the lines will become lighter in shade. At resonance the fewest number of dark horizontal

TABLE A. RESISTANCE ANALYSIS CHART

Tube	Function	1	2	3	4	5	6	7	8
6J5	oscillator	0	0	80K	—	50K	—	0	0
6AC7/1852	mixer	0	0	0	5K	500	150K	0	60K
6AC7/1852	1st video I. F.	0	0	0	2K	100	100K	0	60K
6AC7/1852	2nd video I. F.	0	0	0	2K	100	100K	0	60K
6AC7/1852	3rd video I. F.	0	0	0	2K	220	100K	0	60K
6AC7/1852	sound I. F.	0	0	0	2K	220	100K	0	60K
6SN7	video detector	3K	3K	0	3K	70K	1K	0	0
6N7	video amplifier sync. separator	0	0	9K	1meg	2meg	55K	0	0
6N7	vertical oscillator	0	0	250K	3meg	700K	1meg	0	500
6N7	horizontal oscillator	0	0	190K	110K	80K	500K	0	500
6SN7	horizontal amplifier	2meg	100K	0	2meg	100K	0	0	0
6SN7	vertical amplifier	700K	100K	3K	2meg	100K	1K	0	0
6SQ7	sound detector	0	5meg	0	600K	600K	200K	0	0
6V6	sound output	0	0	50K	50K	1meg	500K	0	500
5U4G	low voltage rectifier	—	50K	—	40	—	40	—	50K
2X2	high voltage rectifier	6meg	—	—	6meg	(top cap 250K)			

All resistance measurements are between designated socket prong and ground. Volume and contrast controls are at maximum (full clockwise). (K = 1000.)



bars will be seen. If the pattern indicated above cannot be obtained with the signal generator connected to the mixer grid as indicated in the previous sentence, proceed as follows:

A. Connect signal generator lead to grid of 3rd video I. F. tube [No. 4 pin on the 6AC7/1852]. Adjust screw on 4th video I. F. transformer for maximum peak as indicated above.

B. Move signal generator lead to grid of 2nd video I. F. tube and adjust 3rd video I. F. transformer in the same manner.

C. Move signal generator lead to grid of 1st video I. F. tube and adjust 2nd video I. F. transformer as above.

D. Move signal generator lead to grid of mixer tube and repeat the whole alignment procedure as outlined at the beginning.

As the signal generator is moved from stage to stage as indicated in progressing from steps A to D, a substantial increase in signal strength should be noted. A loss of signal or a decrease in signal strength between any two of these steps indicates a defect in that particular stage. All of the above adjustments are made with the contrast control in maximum position (full clockwise).

The set is now ready for front end alignment. This alignment will depend upon the stations available in the particular area in which the set is tested. Consult the local newspapers for the television stations that are broadcasting in your area. The frequency channels will be indicated along with the programs listed. Table A gives a few of the stations that are at present operating

TABLE B. VOLTAGE ANALYSIS

Tube	Function	1	2	3	4	5	6	7	8
6J5	oscillator	—	—	175	—	0	—	—	0
6AC7/1852	mixer	—	—	0	0	0	140	—	325
6AC7/1852	1st video I. F.	—	—	0	0	8	310	0	325
6AC7/1852	2nd video I. F.	—	—	0	0	8	310	—	325
6AC7/1852	3rd video I. F.	—	—	0	0	3	195	—	300
6SN7/1852	video detector	—1/2	—1/2	0	—1/2	300	10	—	—
6AC7/1852	sound I. F.	—	—	0	0	3	185	—	280
6N7	video amp. sync.	—	—	38	—1/4	—1/4	280	—	—
6N7	vert. osc.	—	—	45	0	—4	20	—	2
6N7	horiz. osc.	—	—	30	0	1/2	5	—	2
6SN7	vert. amp.	0	185	8	11/24	160	5	—	—
6SN7	horiz. amp.	—2	130	0	—2	165	0	—	—
6SQ7	sound det.	0	—1	0	—1	—1	115	—	—
6V6	sound output amp.	—	—	300	310	0	—	—	6

B. positive voltage 340 volts. All measurements made with a 1000 ohm per volt meter between ground and indicated socket pins, with Contrast and Volume Controls at minimum. No more than 25% variation in voltage readings is permissible. Greater variation than this indicates trouble in circuit.



Vertical size control is incorrectly set.

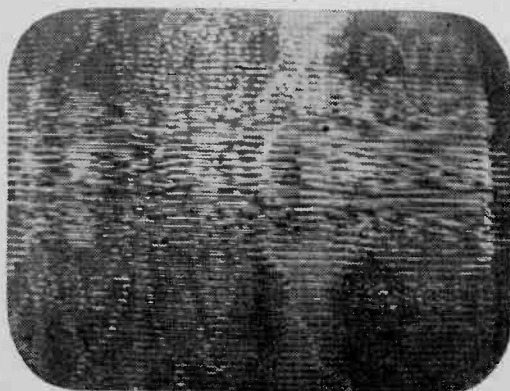

Horizontal hold control incorrectly set.

in large metropolitan areas.

This list is by no means complete and additions are constantly being made to the stations on the air.

In aligning the oscillator the 6J5 tube is now replaced in its socket. An antenna is now connected to the receiver. The type of antenna and the installation of the receiver will be described later. Set the band switch in No. 3 position. Set sound sensitivity control to half maximum position. Now adjust the No. 3 oscillator trimmer until a picture is obtained on the highest number channel. If the sound does not come in at the same time, the trimmer must be readjusted. When properly tuned, picture and sound come in simultaneously. Adjust No. 3 antenna trimmer for maximum sound and maximum picture. It may be necessary to reduce the sensitivity of the total receiver by turning the contrast control

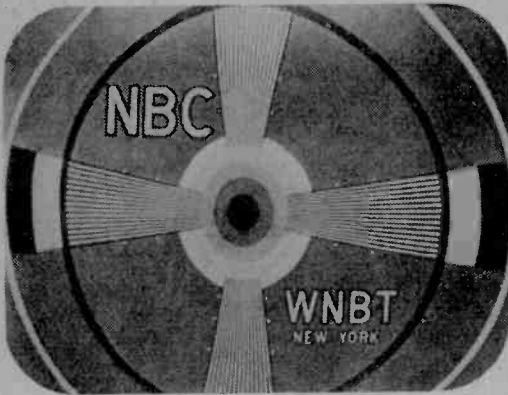

This is the normal test pattern.



Pattern is out of focus.

counterclockwise. Now proceed to No. 2 position on the switch and repeat the above procedure. The No. 1 band may now be adjusted in a like manner. The alignment procedure just described will give the strongest, but not the clearest picture. The previously described procedure should be used as a preliminary step to see that all parts and circuits of the receiver are in proper working order.

In order to obtain a high quality picture from a television set it is necessary that the I. F. amplifier pass a wide band of frequencies and that all these frequencies be amplified equally. The coils incorporated must be stagger-tuned in order for this wide band of frequencies to be passed. The following procedure can be used to give best results:

- A. Set the signal generator to 9 megacycles with modulation on. Connect generator lead to 3rd video I. F. grid (pin No. 4) and adjust 4th video I. F. screw for maximum peak as indicated by darkest and fewest number of horizontal black bars.
- B. Set signal generator to 11 megacycles and connect generator lead to 2nd video I. F. grid. Adjust 3rd video I. F. transformer screw for maximum. Do not readjust 4th video I. F. transformer.

- C. Set signal generator to 10 megacycles and connect generator lead to 1st video I. F. grid. Adjust 2nd video I. F. transformer screw for maximum. Do not touch any of the former adjustments.
- D. Set signal generator to 12.25 megacycles and connect generator lead to mixer grid. Adjust mixer transformer screw for maximum.

This completes the I. F. alignment. In making these adjustments there may seem to be no gain as you proceed from one stage to another. Some of the gain has to be sacrificed in order that band width and high fidelity pictures may result. The reception of television signals on this or any other teletest depends on type of antenna used and adjustment of that antenna. A good outdoor antenna placed well above any surrounding roof tops is an essential item for good results from your television set. There are many good television antennas on the market that will perform well with the receiver described. Bear in mind that the television antenna as well as the set is tuned. This tuning is accomplished by varying the length on the antenna elements themselves. The antenna is then set for one station only. The maximum signal strength will be received from that station and, while other stations will be re-

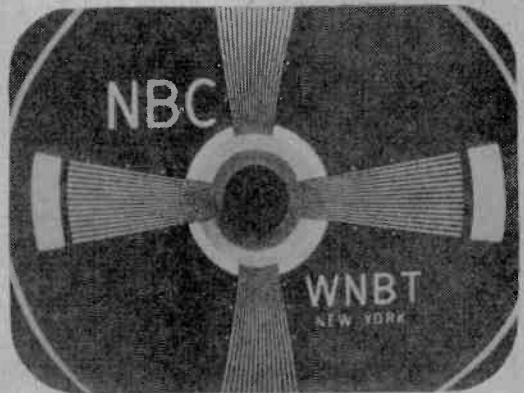

Too much contrast—reduce contrast control.



Vertical hold control incorrectly set.

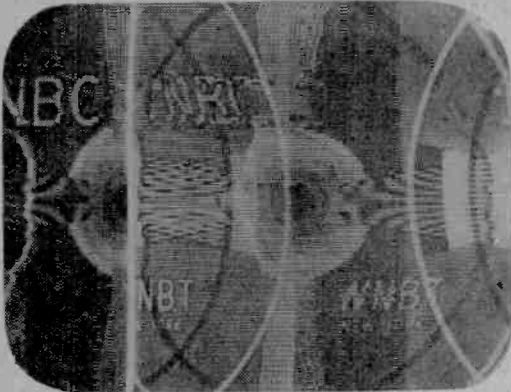

Horizontal hold control incorrectly set.

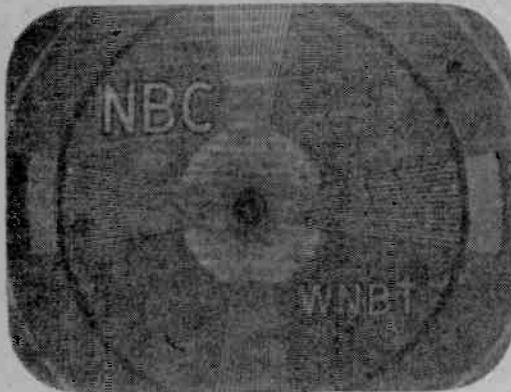

Insufficient contrast—advance contrast control.

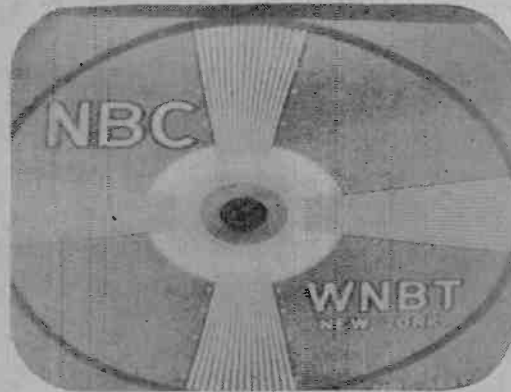

Horizontal size control incorrectly set.

ceived, they will not give as good a picture as the one to which the antenna is tuned. Also, the television antenna is very directional and must face broadside 90° to the direction of the station. Many manufactured antennas come equipped with reflectors which tend to intensify the signal and eliminate pickup from the rear of the antenna.

The antenna shown and described here is simple and effective. It offers good signal pickup

and is easily adjusted. Recently, several manufacturers have announced a type of lead-in wire for television which replaces the former coaxial cable which was very expensive. This wire is known as Twin Lead and is manufactured by American Phenolic Corp. and Federal Telephone and Telegraph Co. It comes in various impedances. For our use, 300 ohm twin-lead must be purchased. The cost per 100 ft. is under \$3.00 and 100 feet is usually sufficient for the average installation. Both the antenna proper and the down-lead are made from this wire. The antenna consists of a piece of twin lead cut to slightly

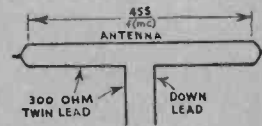

less than 1/2 wavelength. The actual formula for determining the length of the antenna is:

The length in feet is equal to 455 divided by the frequency in megacycles.

For channel 4, the length of the antenna would be 6-ft. 2 1/2 in. For channel 5, the length would be 5-ft. 9 in. Ends of antenna are bared and connected together. The down lead, which may be of any convenient length, is connected by cutting one of the conductors at the exact center point of the antenna and connecting the lead to the two cut ends. This forms a folded dipole type of antenna and is very efficient for reception of television signals. A convenient mounting can be made by cutting a piece of 1 x 2 in. furring strip and mounting a standoff insulator at each end. Attach the ends of the antenna to the standoff insulator. Mount this antenna as high as is possible. To orient it with respect to the station it will be necessary to have an observer at the television set to determine the best position of the antenna, as it is rotated from the roof position. Once the best all around reception is determined, the antenna should be fastened permanently into position. It should be so fastened that it will not be blown down by strong winds nor moved out of its correct orientation.

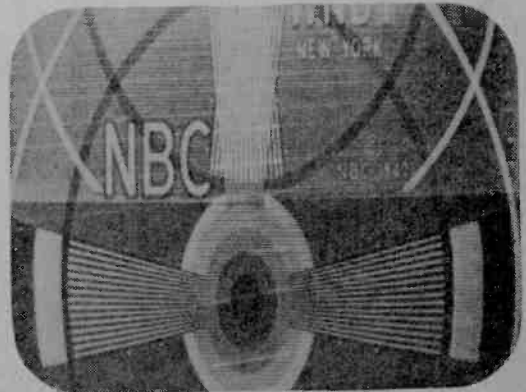

Vertical control incorrectly set.



Pictures showing the correct adjustments to be made by the various controls of the receiver are included for your guidance. And there's your television receiver, ready for its cabinet.

In designing a cabinet for this set, consideration was given to two factors; first, that it should be pleasing to the eye, and second, that it should not be too difficult to construct, and finish. Plywood rather than solid wood is suggested. Mahogany or walnut is most appropriate. Naturally the solid sections, like the rounded corners and moldings, should match the wood used for the panels, sides and top.

The rounded corners on the front of the cabinet give the cabinet an appearance of massiveness. This effect can be easily produced by following these simple instructions. Cut the sides to dimensions, allowing  $\frac{3}{8}$  in. along the width for the rabbet. Cut the rabbets on your circular saw, shaper or drill press. The rabbet and tongue produced will later be inserted in the grooves to be cut along the edge of the corners.

Procure  $1\frac{1}{4}$  in. square stock and cut to length. Then cut a groove along one edge in order to permit tongue of rabbetted sides to fit in snugly

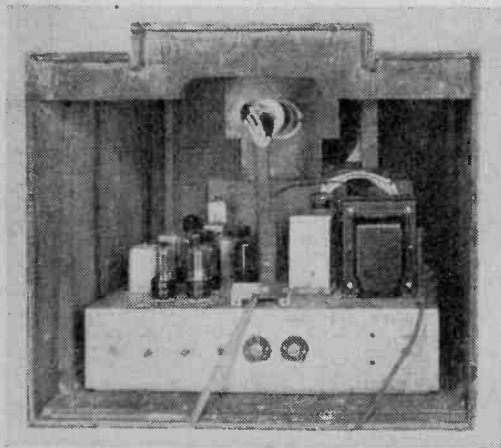

Fig. 2. Rear view of cabinet showing construction details, rear bracket support, and tube support.

LIST OF MATERIALS  
Television Cabinet

No. Pcs.	Description	Thickness	Width	Length
2	Sides (Plywood)	$\frac{3}{8}$	17 $\frac{1}{2}$	16 $\frac{1}{16}$
1	Bottom (Plywood)	$\frac{3}{4}$	17 $\frac{1}{2}$	19 $\frac{5}{8}$
2	Top L & R (Plywood)	$\frac{3}{8}$	4 $\frac{1}{8}$	19
1	Center Top (Plywood)	$\frac{3}{8}$	10 $\frac{7}{8}$	19
2	Top Sides (Plywood)	$\frac{3}{8}$	1 $\frac{1}{2}$	19
2	Corners	1 $\frac{3}{4}$	1 $\frac{3}{4}$	16 $\frac{3}{4}$
1	Re-enforcement bracket	$\frac{3}{4}$	3	19 $\frac{5}{8}$
1	Tube support	$\frac{3}{4}$	7	10 $\frac{1}{4}$
1	Molding $\frac{1}{4}$ round	$\frac{3}{4}$	1	84
1	Molding $\frac{1}{2}$ round	$\frac{1}{4}$	$\frac{1}{2}$	50
16	Corner Blocks	$\frac{3}{4}$	$\frac{3}{4}$	2 $\frac{1}{2}$

Note: All dimensions given in inches.

(Fig. 4). Apply glue to the groove and tongue and glue the members together, using clamps for pressure. When the glue has set sufficiently, draw a  $1\frac{1}{4}$  in. arc at each end of the square stock. In doing this make certain that the scribed arc is on the outside of the square, flush with the side. These arcs now will serve as guide lines. Proceed to shape the corners by planing them to the guide lines on either end of the squares. The contour of the corners should coincide with the arcs drawn. Now sand these down smooth. The corners should now be flush to the sides to which they were glued (Fig. 5).

As can be seen from the photograph the top consists of five pieces, which when assembled will

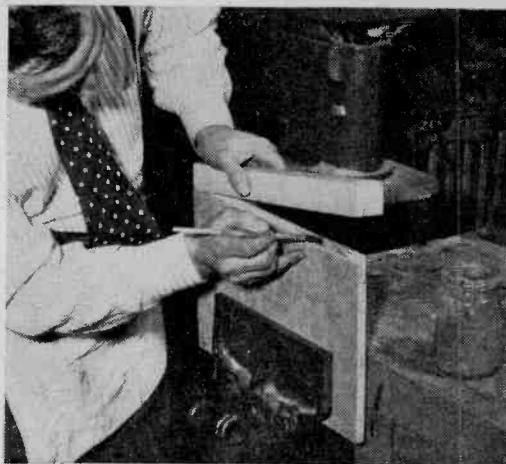

Fig. 4. Shown above is type of joint used in fastening corner to side, and method of gluing members.



Fig. 5. Photo shows method used in shaping rounded corners of cabinet.

produce the effect noted (Fig. 3). Of course, making a top of this nature requires careful study and planning, for not only do we desire the particular shape, but we also desire the top to be strong enough to permit handling, etc. Therefore, a series of simple joints has been used to permit the members to be fastened together without nails or screws. Cut the various members as noted. Make certain that allowance is made for the joints in question. A power saw is



to the top. This is a very important member of the cabinet. Strength of the cabinet depends upon this piece fitting.

The front of the cabinet is embellished with an elongated quarter round molding. This gives the cabinet an appearance of depth. Any type of ready made molding could be used for this purpose, provided it measures  $\frac{3}{4} \times 1$  in. It can also be shaped by hand to match drawing. Cut mitres for the corners so that the 1 in. side rests against front. Be sure that the  $45^\circ$  mitre cuts are accurately made; this is important especially when cutting pieces for the top section. As each piece of molding is measured, cut and fit into appropriate section. Fit all pieces of molding before gluing them in place. Glue and toe nail each piece of molding to sides, bottom, and top. Set nails in and fill in nail holes.

This operation completes the assembling of the entire cabinet. All that remains prior to finishing operations, is to sand surfaces carefully, remove any scratches or blemishes, fill in holes and clean thoroughly.

### Finishing the Cabinet

The finish will depend upon the type of wood used in the cabinet. If mahogany was used then

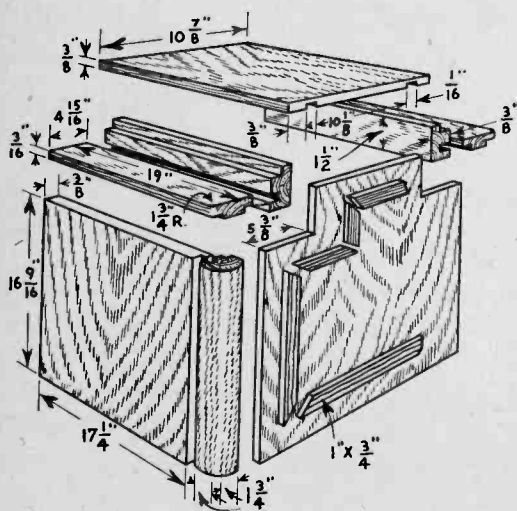

the cabinet should be stained in one of the many shades of mahogany; if walnut was used then a walnut stain should be used. If gum was used, any shade and color of stain can be used. The operation in staining is the same in each case.

Water stain is preferable because of its deep penetrating qualities, and because there is no fading of color with the lapse of time. Ask for aniline (color) soluble in water. Oil stain may be used, but it lacks many of the qualities noted. Assuming that water stain is used, sponge the surface first, then allow it to dry for about four hours. Sand sponged surface with #6/0 garnet finishing paper. This sanding will remove the grain which the water has raised. Brush off dust

thoroughly and then apply the water stain.

Apply stain to the surface with a stiff bristle brush, brushing evenly with the grain. There is no need to wipe off stain if it is brushed on evenly. Do not go over a surface that has already been stained, as this will leave unsightly lap marks which cannot be removed. Allow at least twelve hours drying time before applying next coat.

The open grain of the wood should be filled before shellac or varnish is applied. Pores can be filled by applying paste filler to surface. A pint of paste filler should be sufficient. Make certain that color matches color of stain used. Thin filler with benzine or turpentine to the consistency of heavy cream; then apply evenly to outside surface of cabinet. Within a short time filler will become uniformly dull. Then use burlap or sea grass to wipe off excess filler, rubbing across the grain. When excess has been removed, clean surface thoroughly with a clean rag, wiping with the grain. Make sure that all of the filler is removed from the surface. Filler remaining must be imbedded in the pores of the wood, or gray unsightly marks will appear later where filler was not properly removed.

Again allow at least twelve hours of drying time. When this period of time has elapsed brush on a coat of five pound cut shellac which has been diluted with alcohol about half and half. This coat should be sprayed or brushed on evenly and with the grain. Wait at least three or four hours before applying next coat. Sand previous coat with #6/0 garnet paper before applying new coat. Three or four coats of varnish or shellac should be applied. If varnish is used, obtain a good quality rubbing varnish. Do not thin it down. Cabinet and room must be dust-free and clean. Use a two inch oxhair double chisel type of brush if it is obtainable. Allow at least 12 hours drying time between coats.

Allow ample time for final coat to dry before proceeding with the rubbing operation. If varnish has been used, 24 hours should elapse before this operation is begun. When shellac or lacquer is used, 12 hours should be ample time.

Rubbing and polishing are the last steps in the process. Rubbing the surface implies the wearing away of material. Rubbing will wear away the brush marks and other imperfections which have developed on the finished surface. It will produce a smooth satin-finish surface. This can be accomplished rather easily and at very little cost. Obtain some 2/0 powdered pumice stone, a lubricant like crude oil, a piece of rubbing felt or burlap about 3 x 4 in. in size, and some fine powdered rotten stone. Place oil in a shallow platter, pumice and rotten stone in little piles. Soak the felt pad in the oil, then pick up some pumice with it. With the pad now saturated with oil and pumice begin rubbing the sides. Rubbing action should consist of full, even, straight strokes along the grain. Never rub in a circular motion as this will produce circular scratches on the

surface. After rubbing in this fashion for awhile remove grime by rubbing it off along the grain with a clean cloth. Surface should look satiny and smooth. If brush marks are still visible, continue to rub in the same manner. Avoid over-rubbing; you might wear away all the finish on the surface. Proceed to rub entire cabinet in this fashion. Remove all grime and clean thoroughly.

**High Gloss Finish**

The rubbed cabinet now has a semi-gloss, smooth appearance. Some craftsmen prefer a finish of this type. Others desire a higher gloss. This can be obtained by repeating the process already performed; in this case instead of using pumice, use a clean felt pad and rotten stone as the abrasive. The action of fine powdered rotten stone will produce a fine high gloss finish. Residue should be cleaned off with a soft cheesecloth. Another way of producing a gloss is to apply a coat of rubbing wax to the surface. Allow to dry for about 20 minutes and then rub briskly with a soft cheesecloth. As mentioned previously, a piece of half round molding is to be nailed around the speaker cloth. Before it can be fastened, speaker cloth should be secured in place. Get a piece of ordinary, stiff cardboard and cut a hole in it for the speaker. Apply glue to this and stretch speaker cloth evenly over it. Tack it on the front of the cabinet; then frame with the molding already prepared. Punch holes through this to permit the various dial rods to go through.

**Making the Bracket**

Before installing set into cabinet a bracket should be made (No. 2 in the drawing). This should be prepared in advance so cathode tube can be supported when set is inserted. Fasten upper part of the bracket by gluing it against the underside of the top. A screw on each end will help in keeping it in place. Insert set, and permit dial rods to go through prepared openings on front panel. Fasten on dial knobs. Attach wire to cathode tube and permit the front to rest on support provided with the front panel.

Hold tube in place by fastening rest of bracket to section already installed. Make certain opening for throat of the tube is wide enough. Do not fasten this section unless you are certain of this. You take the risk of breaking the tube if undue strain is used.

Finally fasten a 3/4 x 3/4 in. strip to base of cabinet at end of set. This will help in keeping set firm in cabinet.

● Craft prints in enlarged size for building television receivers are available at \$1.00 a set. Address Craft Print Dept., SCIENCE AND MECHANICS, 450 East Ohio Street, Chicago 11, Illinois. If you would like to have a copy of our special Service Bulletin giving recommended sources of supply for parts to build television receivers, just send a 3c stamp for Bulletin 1048. Address: Readers' Service Bureau, SCIENCE AND MECHANICS, 450 East Ohio Street, Chicago 11, Ill.

FREE!



Get ALLIED'S  
RADIO BUILDERS'  
BUYING GUIDE!

Everything You Need  
from the Leading  
Radio Kit Suppliers

**Headquarters for Builders & Experimenters**

For more than 20 years, Radio Builders and Experimenters have turned to ALLIED—the World's Largest Radio Supply House—for the equipment and help they need in radio construction. You'll find everything you need in ALLIED'S great catalog—thousands of parts, tubes, tools, kits, books, diagrams—all at lowest money-saving prices!

WE CAN SUPPLY all parts for constructing any of the radio kits and units described here, as well as parts for building any radio circuit described in any other publication. Write to our Kit Division for complete parts lists and money-saving prices.

**ALLIED'S RADIO KIT SPECIALS**



**LOW-COST SUPERHET "RANGER"**  
Complete with Plastic Cabinet,  
Loop Antenna, and Tubes

The first ultra-modern 5 tube AC-DC Superhet kit at so low a price! Tunes 550-1600 kc.; built-in antenna; 5" PM dynamic speaker, handsome walnut plastic cabinet. Easy to assemble. Complete with tubes and instructions, less wire and solder. Shpg. wt., 7 1/2 lbs. No. 83-275. Only ..... \$15.50

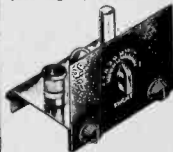

**"OCEAN HOPPER" KIT**

Famous, easy-to-build 2-tube marvel! All-wave coverage from 9.5-550 meters with plug-in type coils. Amazingly sensitive and powerful—literally an "Ocean Hopper" in performance. For use with PM speaker or headphones.

Has electrical bandspread as well as main tuning control. Complete with tubes, coils and instructions, less wire and solder. Shpg. wt., 8 lbs. Only ..... \$18.35

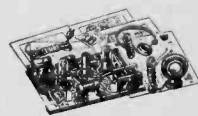

**FAMOUS RADIO LAB KIT  
10 RADIO KITS IN 1!**

Here's a great Experimenter's Kit. With it, you can build a broadcast receiver, phono amplifier, phono oscillator, signal tracer, electronic timer, code practice set, home broadcaster, electronic switch, etc. Instructive, fascinating, easy construction. Complete with all necessary parts, tubes and 12-page manual, less wire and solder. Shpg. wt., 10 lbs. Only ..... \$13.75

**OTHER POPULAR LOW-COST ALLIED KITS**

- 83-309. 2-Tube Battery "DX-ER", with tubes. .... \$10.75
- 83-221. TRF Broadcast Tuner, with tubes. .... 24.25
- 83-222. 10 Watt Hi-Fidelity Amplifier, with tubes. ... 22.75

(All prices shown are net FOB Chicago)

**WRITE TODAY FOR FREE 180-PAGE CATALOG!**

**ALLIED RADIO CORP.**

833 W. Jackson Blvd., Dept. 3-Z-9 Chicago 7, Illinois



# Pee Wee Oscillator

## MAKES CODE PRACTICE EASY

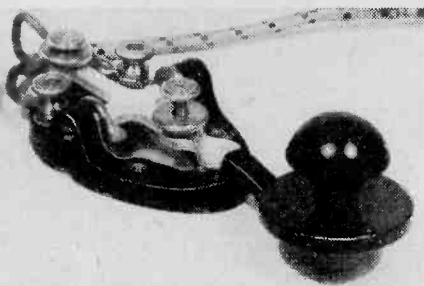
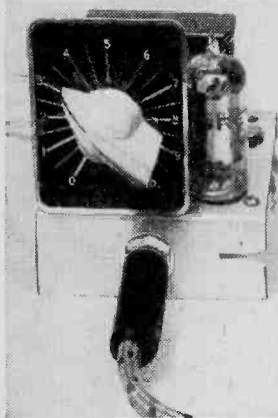

Pee wee code practice set is overshadowed by transmitting key at right. Complete outfit will fit in cigar box.

few inexpensive and easily obtained components. Because it is battery powered, it is completely portable and may be packed along with key and headphones in a cigar box. The small current drawn by the miniature 1T4 pentode tube's filament permits a regular flashlight cell to furnish the A battery voltage. A small 22½ or 30 volt B battery will last for months.

The oscillator shown here was assembled on a 2½ in. square, 1 in. high metal chassis. But the components may be wired up on a wood base, inside a metal box, etc. if you prefer. Simply follow simplified picture

To join the 70,000 "hams" and "get on the air," you must be able to send and receive code. This set makes code practice fun!

By THOMAS A. BLANCHARD  
Electronics Engineer

**H**ERE is a simple audio-tone code oscillator with which you can master code transmission. If you want to get on the air with your own amateur station, the Federal Communications Commission requires that you be able to send and receive 13 words a minute in International Morse Code.

The tones of this oscillator are made variable by the high resistance potentiometer in the grid circuit of the 1T4 oscillator tube. Thus you can simulate the exact sound of a CW (continuous wave) transmitter as it would be heard on a shortwave receiver. This oscillator consists of a

picture wiring plan after parts have been mounted. The iron core oscillator coil is provided by a standard "push-pull" midget radio output transformer, the type used to drive PM speakers. The low impedance voice coil secondary is not used. The primary high impedance side is center-tapped. The resistance may be any value from 5 to 25 thousand ohms. A ⅝ in. hole is provided in the front right corner of the chassis for the 7 pin miniature tube socket. Drill a ⅜ in. hole in center of front chassis apron for key jack. Drill two ⅜ in. holes in rear apron for phone tip jacks. Make sure you provide insulation between

### MATERIALS LIST—PEE WEE OSCILLATOR

- 1 2½ x 2½ x 1" chassis (form from 2½ x 4½" piece of aluminum, steel, etc.)
- 1 Audio output transformer with C.T. Primary impedance from 5,000 to 25,000 ohms.
- 1 2 megohm potentiometer
- 1 250 mmf. mica condenser (capacitor)
- 1 7 pin miniature socket (Amphenol type 147-500)
- 1 Single pole, single throw toggle switch
- 2 Phone tip jacks
- 1 Key Jack
- 1 Dial plate (optional)
- 1 Bar pointer knob
- 1 1½ volt A battery (flashlight cell)
- 1 22½ or 30 volt B battery
- 1 1T4 miniature pentode tube
- Misc. hook-up wire and hardware

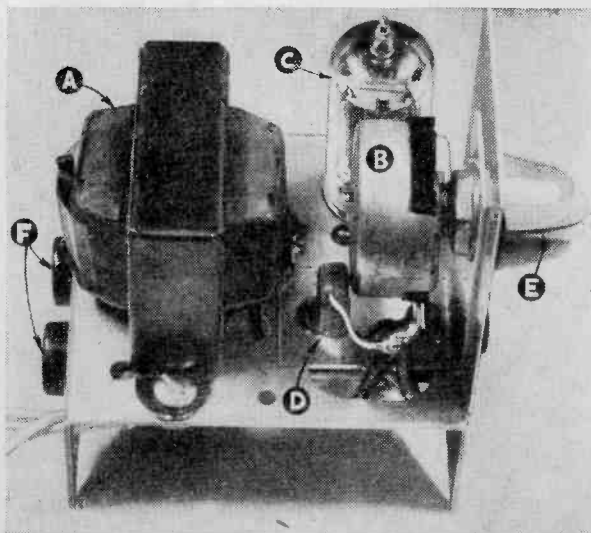

Closeup view of chassis: (A) transformer; (B) potentiometer; (C) 1T4 tube; (D) 250 mmf. condenser; (E) tone adjustment knob; (F) tip jacks.

TABLE A—INTERNATIONAL MORSE CODE

A	—	J	—	S	—	2	—	—
B	—	K	—	T	—	3	—	—
C	—	L	—	U	—	4	—	—
D	—	M	—	V	—	5	—	—
E	—	N	—	W	—	6	—	—
F	—	O	—	X	—	7	—	—
G	—	P	—	Y	—	8	—	—
H	—	Q	—	Z	—	9	—	—
I	—	R	—	1	—	0	—	—
		PERIOD	—	—	—	—	—	—
		COMMA	—	—	—	—	—	—
		? MARK	—	—	—	—	—	—

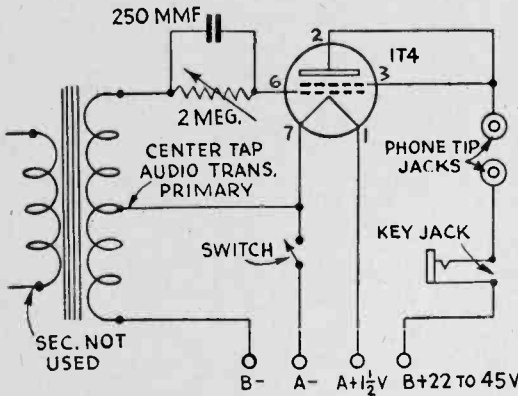

SCHEMATIC - CODE PRACTICE SET

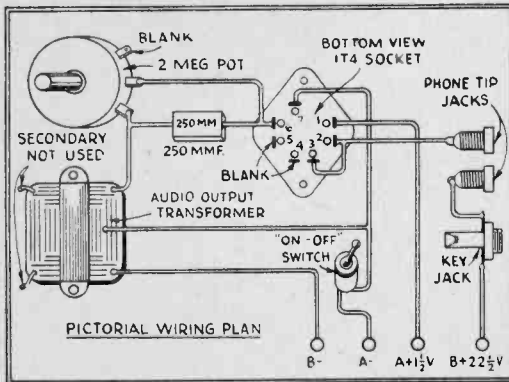

PICTORIAL WIRING PLAN

jacks and chassis when mounting.

Mount the 2 megohm potentiometer on a bracket which also supports the dial plate. This bracket may be purchased or fashioned from a strip of aluminum, etc. Because dimensions of components will vary, obtain parts first, so mounting holes may be drilled to fit.

Because the code practice set is battery powered, even a homemade transmitting key can be used without danger of shock. Or, you can buy the type shown here. The transmitting key is in series with the plate supply and phones, and acts as a momentary switch producing oscillation in headphones when key is closed. You can therefore insert an additional key and set of phones in series with the original for two-way code practice. When receiving, hold your key closed to estab-

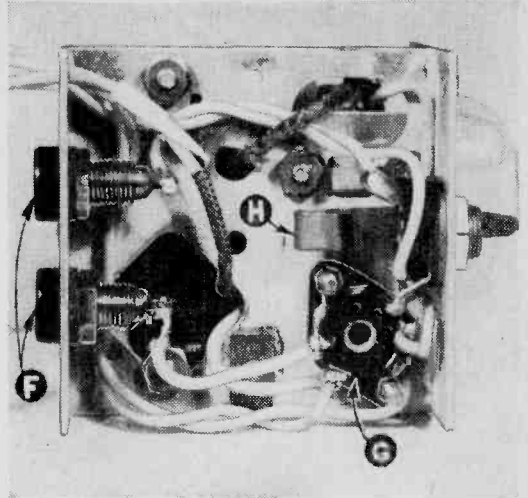

Bottom view of oscillator: (F) phone tip jacks; (G) tube socket; (H) key jack.

lish a circuit for the other operator. Likewise, his key must be held closed when you are transmitting. If key has a shorting switch on the base it is unnecessary to hold key down while your partner is sending.

As many as five or six sets of phones and keys may be placed in series for group code practice. However, for this use it may be necessary to increase B battery voltage to 45 or 90 volts. For solo use, use headphones with a resistance of about 2000 ohms. Use two pairs of 1000 ohm headsets if you practice with a friend. Where a group is involved, war surplus headphones with 250 to 500 ohm magnets are ideal and economical. For future reference and study, save the code chart which accompanies this article (Table A).

### Rapid Connectors for Experimenting

• Make connectors for radio and electrical experimenting by tightly wrapping about 15 turns of stiff copper wire around a pencil to form a spring. Straight end of coil is fastened in binding post; additional wires can be slipped into coil and pulled out again quickly. Phosphor-

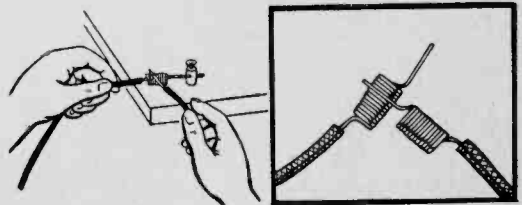

bronze wire makes the best springs but a stiff grade copper wire is satisfactory. Separate spirals by a slight pull and slip other wire into place, making a secure electrical contact which will not easily loosen during tests.—ARTHUR TRAUFFER.

# Dial a Tune RADIO

Try converting a plastic playphone into a real battery-powered radio

By THOMAS A. BLANCHARD



Turn the dial and tune in a station. Toy phone contains battery powered set.

ANY youngster will welcome this novel telephone radio that really works. The phone is the two-third scale plastic toy model carried by most toy and variety stores. To convert the playphone into a radio, first disassemble. Remove fiberboard cover on the base by applying a hot soldering iron to each plastic swage (rivet), then lifting up the fiberboard. Heat melts swaged studs instantly. Dial and ratchet are attached to inside of phone base with a drive screw. Each drive screw resembles a steel rivet, but comes off easily if you grasp head with pliers and twist to left.

Rivet flare securing finger stop to phone base may be cut off by reaming with a 1/4 in. twist drill. Then pull off finger stop. Remove dial and return spring from phone base. Discard everything but dial and fingerstop. Note molded stop on back of dial as well as on phone base which allows dial to make but a single revolution. Remove stop from phone base by grinding off or cutting away with razor blade or knife. Stop is removed so dial serves to tune radio. It takes three complete dial revolutions to tune from minimum to maximum capacity with the 250 mmf. compression type condenser.

At a point 2 3/8 in. horizontally across dial from small hole where finger stop was located, drill a hole large enough to clear a No. 4-40 machine screw. Enlarge finger stop hole to accept a No. 4-40, too. Complete work on base by drilling or reaming a 3/8 or 1/2 in. hole for the "on-off" switch. Size of hole will depend on make of switch. We used an inexpensive rotary switch as sold in 10-cent stores. Switch mounts in recess behind the handset cradle. Exact location may be noted on underside of base. Switch hole is drilled on the oval trademark, "Ideal."

When buying the playphone, look for one with the earphone cap not too well cemented to the handset shell. By soaking

in warm water, you can remove the cap intact. If cap is firmly secured, cut it off by working a razor blade around the seam edge; plastic is soft and cuts easily. One of the most common earphones is the Army surplus type R-14. This unit is the same diameter as handset receiver shell. After wiring the earphone and drilling a 1/4 in. cord hole in back of shell, headphone makes a perfect fit. A 3/8 in. strip of

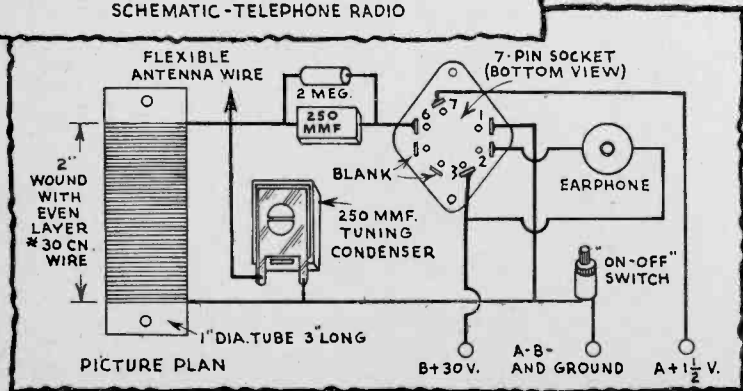
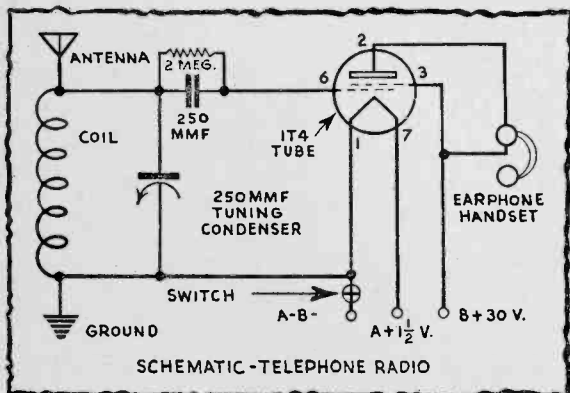

Scotch tape around the edge secures earphone rigidly to shell. It may also be attached with Duco or Ambroid cement. Apply cement to under-edge of earphone only and set. Since plastic will soften, avoid an application of cement on shell.

Receiver circuit is a very simple, tuned radio frequency type. A few inexpensive parts are used, so little or no previous radio experience is needed to assemble set and get results! Chassis is a piece of aluminum, copper or tinplate. It may be any available gage; we used No. 20 soft aluminum measuring  $2\frac{7}{8}$  by  $2\frac{1}{2}$  in. Drill holes according to accompanying layout. Place panel in a vise and make two bends as shown. Bend section with tube socket hole at right angles ( $90^\circ$ ), forming a shelf. Half-inch bend at opposite end of chassis is approximately  $30^\circ$ . It provides an offset mounting for the coil as shown in photos.

The components are now ready for mounting. First wind coil on a cardboard or fiber tube 1 in. in dia. and 3 in. long. Wind a single, even layer of No. 30 enameled copper wire to fill a  $2\frac{1}{2}$  in. space on coil form. A coat of Duco cement or shellac will keep winding secure. Mount coil to chassis with two  $\frac{1}{2}$  in. No. 4-40 screws. Mount 250 mmf. compression condenser (tuner) in  $\frac{3}{4}$  in. hole in center of chassis. First check threaded shaft to determine if enough thread is exposed when plates are loose. If you do not have about  $\frac{1}{4}$  in. of exposed thread, partially remove this screw and saw off  $\frac{1}{4}$  in. of the mounting bushing. After installation of 7-pin miniature socket, chassis is ready for wiring. Wire according to plan. Remove enamel from ends of coil wires and solder connections clean and solid. Only faulty wiring and/or soldering will prevent set from working.

Chassis is now ready for mounting in phone

base. First insert a 1 in. by 4-40 machine screw in finger stop and also in hole drilled opposite it. Run a nut up on each screw and draw tight. Phone dial should be replaced at this point. Run extra nuts, or use metal spacers, or wood beads, on screws to provide proper spacing for chassis. With condenser screw still loose, position chassis. Then run a final nut on each of No. 4-40 mounting screws. Before tightening, however, hold phone dial rigid, and compress tuning condenser with screwdriver, forcing lead-end of screw to thread itself onto the dial. Do this threading beforehand so dial will attach freely at final assembly. It may be necessary to enlarge hole in dial stud slightly. Because the plastic is soft, condenser screw will cut a perfect thread. With dial attached, jockey chassis on mounting screws to insure free dial movement. Then draw nuts up se-

MATERIALS LIST  
DIAL RADIO

- 1 "Ideal" Plastic Playphone
- 1 Piece #20 gage metal;  $2\frac{7}{8}$ " by  $2\frac{1}{2}$ "
- 1 250 mmf. compression condenser (trimmer type)
- 1 250 mmf. fixed mica condenser
- 1 2 megohm,  $\frac{1}{2}$  watt resistor
- 1 7-pin miniature socket
- 1 Rotary switch
- 1 Surplus Army R-14 earphone
- 1 Minimax 30 v. B battery
- 1 Penlite battery
- 1 Homemade Coil (see article)
- Misc. hook-up wire, hardware

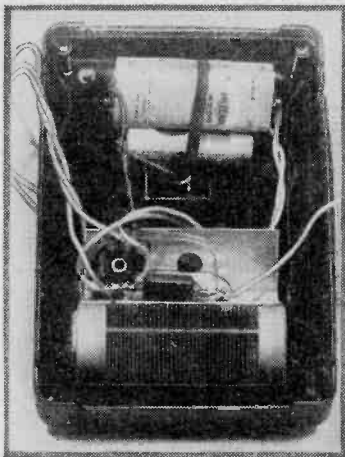
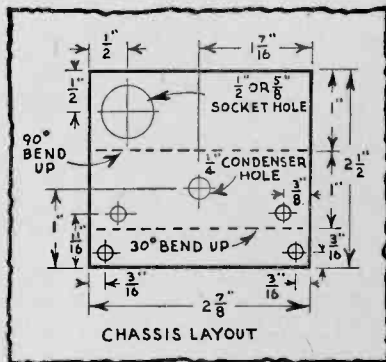

Left, bottom view of telephone with chassis and miniature battery power installed. Below, chassis and batteries ready for mounting in base of telephone. Note rotary power switch.

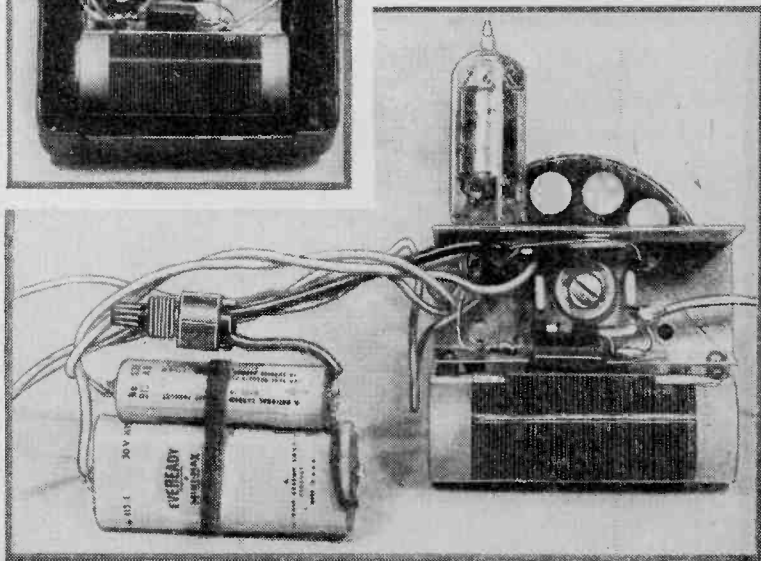



curely. Rotating phone dial causes tuning condenser to open and close.

Set is powered with a single penlite cell (1½ v.) and a miniature 30 v. B battery, both contained in the set. Earphone cord, antenna, and ground wires come out through slot in phone base. Fiberboard bottom may be replaced, but we discarded it since miniature 1T4 tube is well protected against damage. Usually by connecting

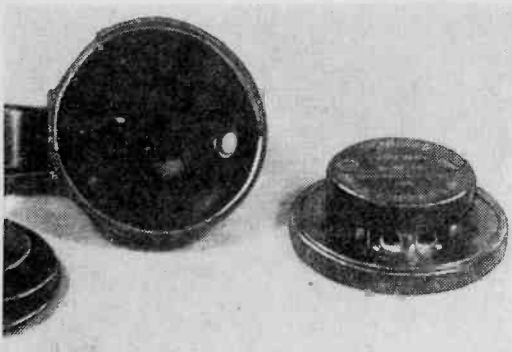

Close-up of handset and dummy cap at left. R-14 receiver makes perfect fit in shell.

the antenna wire to a bedspring, and the ground to water or steam pipe, plenty of kick results on local stations. In many instances, no ground is necessary. The better the antenna and ground,

however, the greater the range and power of this little radio set.

The coil described favors stations from 550 to 1200 KC. If stations in your locality are down between 1300 and 1500 KC, remove about 25 turns from either end of coil. Same effect is obtained by placing a small coupling condenser in series with the antenna. Two postage stamp size pieces of tin will do. Solder a wire to each plate, insert thin cardboard between them so the two plates do not actually touch each other. Bind together with Scotch tape. Varying amount of spacing between plates by using additional cardboard, will prove interesting. It is not necessary to operate this set on the 30 v. cell we used. A 22½ or 45 v. battery is suitable. Or, buy penlight cells and wire them up in series for any desired plate voltage.

### Simple Experiment Demonstrates Electrolysis

• A penny and a dime or nickel separated by a saliva-moistened piece of paper or rag make a coin wet cell and demonstrate the electrolytic action of dissimilar metals. A sensitive voltmeter attached to the coins indicates the slight voltage created by the cell.—FRED E. EBEL.

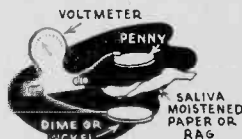

## Why don't YOU train for Television — at C. T. I.?

"Take it from me," says George Brewer of Indiana. "I'm certainly using my time to the best possible advantage! I'm in training at C.T.I. for a future as a television technician. When I receive my diploma in a few weeks, I feel sure I can tackle any installation or repair job!"

The student who trains at C.T.I. learns his trade from the ground up. For instance, one of his projects is to build a complete television set. He works on actual equipment, in a modern shop, under expert supervision. He learns to do by doing!

Plan now to get into television—America's fastest growing industry. Train at nationally-famous C.T.I. Fill out and mail the coupon today!



**FILL OUT - CUT OUT - MAIL TODAY**

**COMMERCIAL TRADES INSTITUTE, Dept. E4-H**  
1400 Greenleaf, Chicago 26, Ill.

Veteran  
 Non-Vet.

Send free illustrated booklets and other information about the field I have checked below:

- |   |  |
|---|--|
| <input type="checkbox"/> Electricity & Electronics        | <input type="checkbox"/> Automotive Mechanics  |
| <input type="checkbox"/> Radio & Television               | <input type="checkbox"/> Body & Fender Repair  |
| <input type="checkbox"/> Commercial Radio Operator        | <input type="checkbox"/> Diesel Mechanics      |
| <input type="checkbox"/> Refrigeration & Air Conditioning | <input type="checkbox"/> Building Construction |
|   | <input type="checkbox"/> Mechanical Drafting   |

Name..... Age.....

Address.....

City..... State.....

### VETERANS! C. T. I. TRAINING IS G. I. APPROVED

All C.T.I. courses, both residential and home study, are fully approved by the Veterans' Administration—which means that eligible veterans will have their tuition paid by the government. Remember, there's a time limit on when training must begin, so act now. **NON-VETERANS**—Ask for information on our Easy-Payment Plan!

### COMMERCIAL TRADES INSTITUTE

1400 Greenleaf Dept. E4-H Chicago 25, Illinois

# Short Range FM CONVERTER and Pocket Radio

Here's a simple converter, requiring only three parts, designed particularly for those located near the FM stations

By DONALD J. RATHMANN

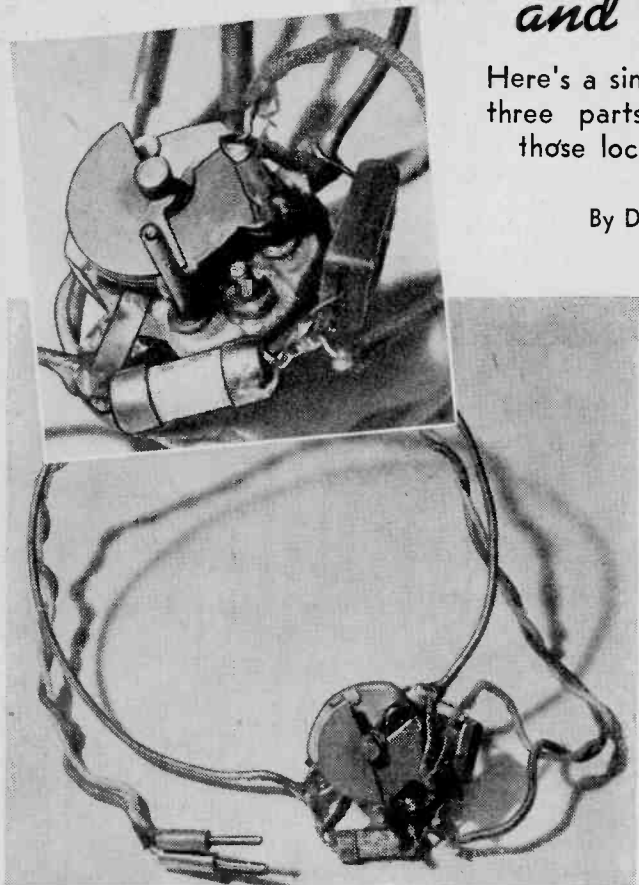

Rear view of the FM converter; inset shows an enlarged view. If used within sight of the FM transmitter tower, no aerial is needed.

**F**OR those of you who live near FM stations, here is a simple FM converter which will enable you to receive FM programs with a regular AM set. This discriminator can also be attached to an earphone to be used as a pocket FM radio. It can be made in one hour at a cost of two dollars. *Ed. Note: Don't expect multitube set selectivity and sensitivity with this set. We think it's a good gadget if you live very near an FM station.*

The set is beautiful in its simplicity and has only three parts. It consists of a 10 to 30 micro-microfarad variable condenser (A), an IN34 fixed crystal (B), and a .0001 microfarad fixed condenser (C). Twelve inches of No. 10 copper wire are required for the loop coil (D).

Rigidity and compactness are achieved by attaching the crystal and fixed condenser to the frame of the variable condenser. This can be seen in the pictorial diagram. To make this connection, it is necessary to bolt two lugs (1 and

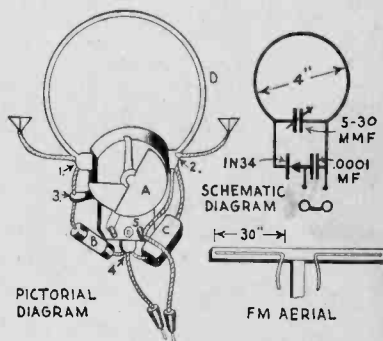

2) in the threaded holes in the frame of the variable condenser. The ends of the loop of copper wire (D) are soldered to the lugs (1 and 2). This circle of wire should have a diameter of four inches.

Next solder a wire from the crystal to the rotor terminal (3) and to the left lug (1). Solder the other wire of the crystal to the insulated bolt (4). The wires of the fixed condenser are soldered to the insulated bolt and to the right lug (2). Output leads are connected to the insulated bolt and plate terminal (5). A short wire is then inserted to connect the plate terminal and right lug. The converter is then complete.

For use as a pocket radio, connect the output leads to an earphone. It will operate without an aerial within sight of the FM transmitter tower. Addition of the aerial, described in this article, increases the volume and range.

An FM aerial is required for use of the converter on an AM set. A simple one can be made by stapling two pieces of No. 10 wire, 30 inches long, to a board. The board can then be nailed to a support. Erect the aerial in a horizontal position and perpendicular to the direction of the station. It must be placed within sight of the FM tower and as high as possible. For operation, connect the aerial leads to the lugs (1 and 2) on the converter.

To connect the converter to your radio, insert the output leads into the phone input sockets of

your set. If your radio has no receptacles, connect the lead from the insulated lug (4) to the grid of the first detector tube and the other lead to the chassis. The converter has been used with tuned radio frequency and superheterodyne sets.

Amplification can be increased in three ways if desired. A radio frequency amplifier can be

inserted between converter and aerial. Installation of an audio preamplifier between the converter and radio can also be used. A third method is to use a wireless phonograph. The output of the converter is connected to the phonograph and the amplified signal is then picked up on the radio.

# Super POWER MIDGET

Although only a handful, this 4-tube superheterodyne has amazing power. And its cabinet, specially designed for you, makes it a set you'll be proud to have in your home

Receiver unit designed by  
**T. A. BLANCHARD**  
Electronics Engineer

Cabinet designed by  
**HENRY P. GLASS**  
Designer, A.D.I.

IT IS not a stretch of the imagination to say that if you can build a one or two tube set you can then produce an honest-to-goodness commercial type superheterodyne as described here. Many radio trainees are told to graduate from the very simple set to making a T.R.F. receiver. Yet, in reality, the T.R.F. which lacks both power and sensitivity, involves more components and assembly time than this powerful midget superhet.

Usually the experimenter is frightened away from a set of this type, because a glance at the schematic diagram leads him to think that wiring is too complicated. However, take a look at the pictorial plan. All connections are in clear sight. Therefore, if you merely connect up the components as shown, your efforts will be repaid tenfold in personal achievement.

A considerable amount of wiring has

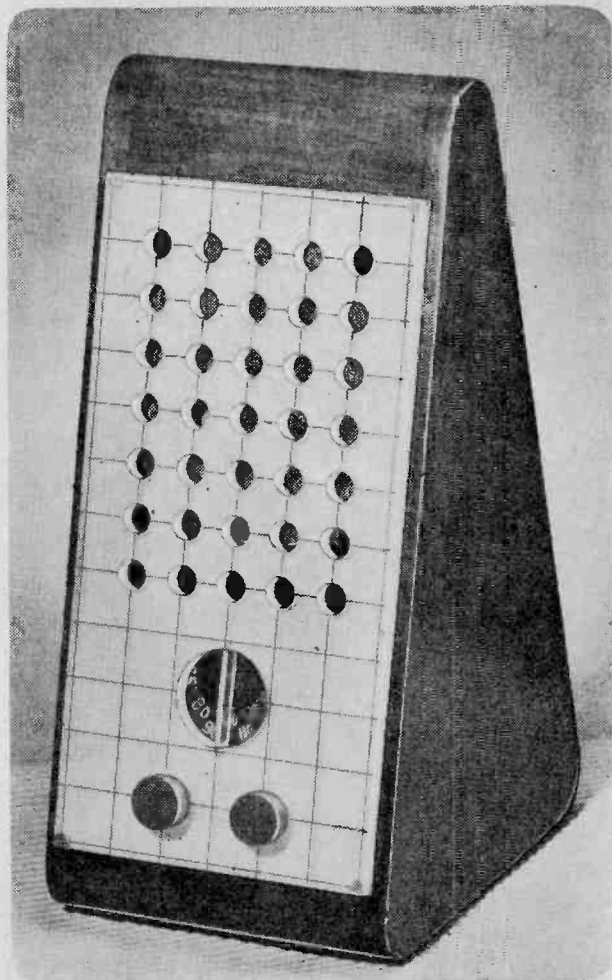

## Introducing the Designers . . .

● When expert radio designer Tom Blanchard sent us this powerful and compact superhet, we thought it was such a fine radio that it deserved a specially-designed cabinet. So we asked one of the country's foremost industrial designers, Henry Peter Glass, to plan a special cabinet for the superhet—and this is the result.

Mr. Glass, after intensive schooling in design work in Vienna, came to this country in 1939 and worked with Gilbert Rhode and other top New York designers. He has since worked with W. L. Stensgaard of Chicago on store and showroom planning, and packaging, appliance, and product design. In 1946 he founded a firm under his own name in Chicago. In addition to his work for prominent manufacturing firms, he teaches industrial design at the Chicago Art Institute, and is Chicago Chapter President of the American Designers' Institute.

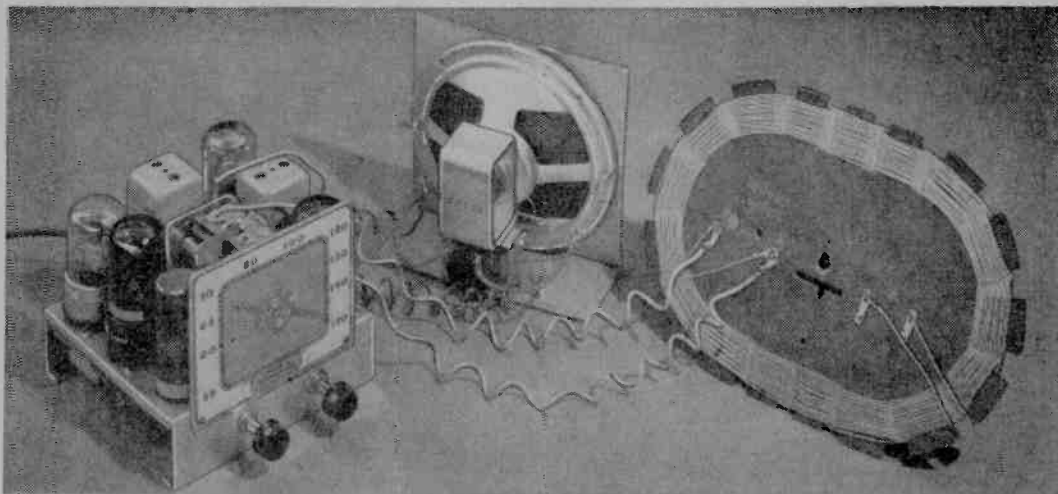

Receiver unit shown prior to assembly in cabinet. Receiver dial will be replaced when unit goes into cabinet.

been eliminated by using the chassis as a common ground connection. If all points in the circuit that are grounded, are wired in first, simply by running a short piece of bare wire to the nearest point on the chassis to which it can be secured, you will find that you have completed about 35 percent of the work. Having accomplished this, connect the tube heaters in series (just as you would Christmas lights) and wiring is then 50% done. The remainder is completed from here on in with a minimum of confusion, by marking the pictorial plan with

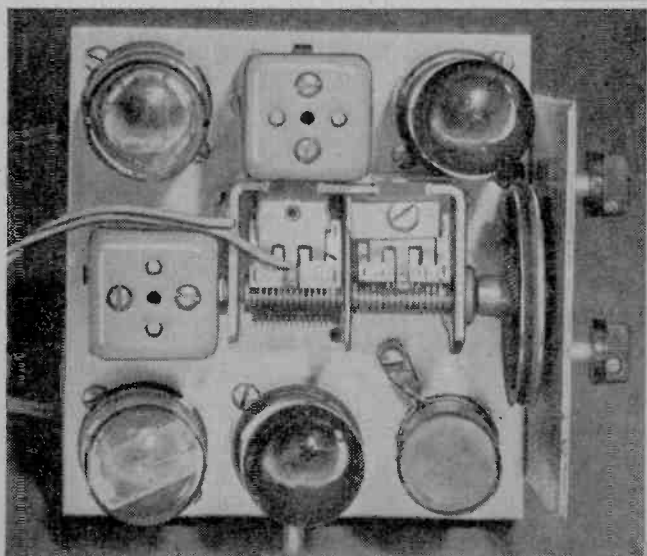
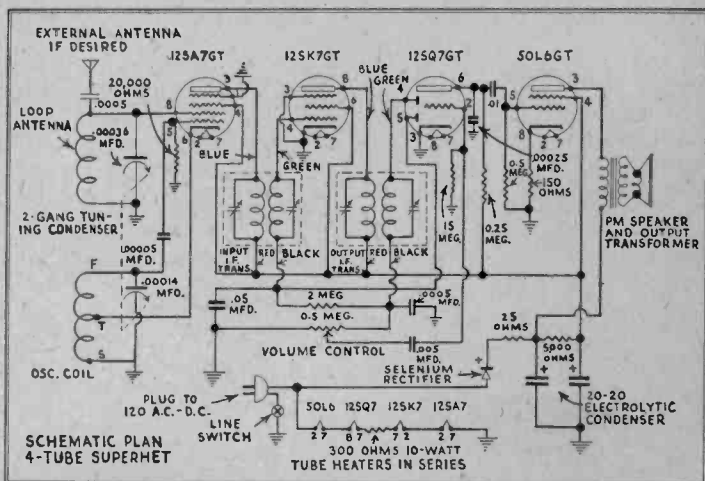

crayon as each wire is installed.

Having waxed your enthusiasm by this time, let's look at this project from the beginning. First, you will need a chassis on which to construct your set. The original model was built on a chassis that started out as a piece of #20 aluminum, 5 inches wide and 8 1/4 inches long. It was then bent to the shape shown: 5 by 4 1/2 by 1 1/2 inches deep.

We do not advocate any hard and fast rule on the chassis. It may be larger than shown, and arrangement of parts varied to suit their mechanical or physical characteristics. A chassis layout is not shown here because all too often the constructor finds that the parts he obtained do not line up with original plans.

Birds-eye view of the completed receiver unit, showing components.

## BILL OF MATERIALS

- |   |  |
|---|--|
| 1—piece aluminum 5 by 8¼ inches for chassis | 1—.05 megohm volume control and switch     |
| 4—octal tube sockets                        | 1—permanent magnetic speaker               |
| 1—Seleton rectifier                         | 1—output transformer to match speaker used |
| 1—dial and pointer                          | Miscellaneous nuts and bolts               |
| 1—6 foot cord and plug                      |  |

## CONDENSERS

- 1—2 gang tuning condenser (.00036 mfd. with oscillator section)
- 1—20-20 mfd. electrolytic condenser, 150 w.v.
- 1—.00005 mfd. fixed condenser
- 1—.00025 mfd. fixed condenser
- 1—.0005 mfd. fixed condenser
- 1—.005 mfd. fixed condenser
- 1—.05 mfd. fixed condenser
- 1—.01 mfd. fixed condenser

## FIXED RESISTORS

- 1—15 megohm resistor (½ watt)
- 1—2 megohm resistor (½ watt)
- 1—.5 megohm resistor (½ watt)
- 1—0.25 megohm resistor (½ watt)
- 1—20,000 ohm resistor (½ watt)
- 1—5,000 ohm resistor (1 watt)
- 1—150 ohm resistor (½ watt)
- 1—25 ohm resistor (1 watt)
- 1—300 ohm wire wound (10 watt)

## COILS

- 1—antenna loop (see text)
- 1—input I.F. transformer (455kc.)
- 1—output I.F. transformer (455kc.)
- 1—oscillator coil (455kc.)

The procedure is to first obtain all the necessary components, arrange them on the blank chassis, and then drill holes accordingly. While electrically, a given radio component will match a dozen other makes, its method of mounting, size, etc., often vary a great deal. Needless to say, you will save time to obtain your parts first, then make the chassis to suit the components.

The general layout of parts is obvious after examining photos and pictorial plan. The 2-gang tuning condenser is placed in the center of the chassis, with tubes, electrolytic condenser and I. F. Coils (Intermediate Frequency Transformers, to be fancy) grouped around it. Except for these items, all other parts (including tube sockets) are under the chassis. The I. F. Transformers have flexible leads which are color-coded, as has the electrolytic condenser. These wires are merely passed through suitable holes in the chassis and wired from the underside just as shown in picture plan.

By employing a selenium rectifier, we have eliminated a tube from the circuit, and simplified wiring. This mounts on to rear chassis apron as shown. The volume control and dial drive mount in ⅜ inch holes on the front apron. Incidentally, this drive may be replaced with a simple bar pointer knob on the tuning condenser shaft if the vernier tuning feature isn't desired.

The best feature of this set is that it will operate in most localities without an antenna since the antenna coil is actually a "loop." This item may be purchased or made. To make the coil simply wind about 30 turns of #24 to #28 magnet wire (enameled or cotton covered) around 4 nails spaced on a 5 by 7 rectangle. When winding is completed, pull out the nails, and fasten coil together with tape. Connect one end to the chassis of your set, and the other end to the rear stator (fixed) plates of the 2-gang condenser. A

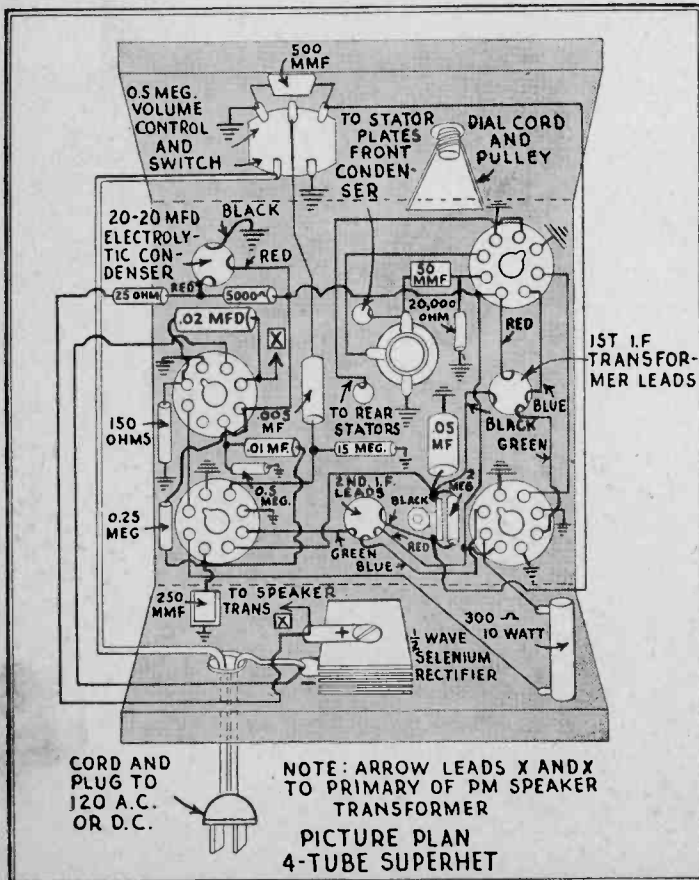



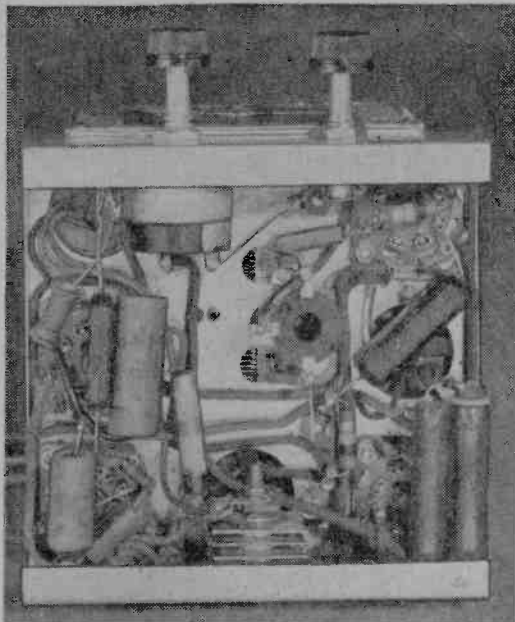

Underneath view of receiver showing connections.

ready made loop may be purchased, if desired.

If an outside antenna is needed, connect it through a .00025 or .0005 mfd. fixed condenser to the same stator plates to which the loop is securely fastened.

Condensers shown across I.F. Transformers are built into unit and adjusted by means of screwdriver. Usually these are preset at factory and should not be touched. If some adjustment is needed take the following steps: First, tune in to a very weak station. Then adjust screws on Output Transformer, first to loudest volume; then do same on Input I.F. Use insulated screwdriver, and remember to tamper with these coils as little as possible.

Because of its compact design, this set lends itself to a variety of uses. It may be built into home furniture, into a wall, or housed in the conventional cabinet. Any size speaker may be used so that exceptional tone can be expected with a larger PM speaker. One craftsman who saw this model, suggested the set be built into the arm of an easy chair, with the speaker located across the room in an attractive wall baffle. Well, that's one man's idea. And here's another.

### Making the Cabinet

After you have your kit all assembled, after you have gotten over the first shock and found out that it actually plays, you might not be contented with the idea of having to carry your set with chassis, loudspeaker, and antenna dangling around on a bunch of loose wires. Well in that case, here is a suggestion as to how you can build a simple, easy-to-make cabinet which will make a handsome cradle for your noisy little pet. Not only will it look pretty, but it will be easy

to carry from room to room and it will occupy a minimum of space wherever you put it.

Want to make it? All set! Here is the recipe. First, prepare the following pieces in accordance with index letters on cross section.

For the sides (A) two triangles with rounded corners are cut according to the dimensions shown in the drawing (7 $\frac{3}{4}$  inches at base, 13 $\frac{1}{2}$  inches high and cut out of  $\frac{1}{2}$  inch solid lumber. The front edge has  $\frac{1}{4} \times \frac{1}{4}$  inch rabbet, 10 $\frac{7}{8}$  inches long, which receives front panel C.

For the back (B), cut one piece of solid lumber 5 $\times$ 10 $\frac{1}{2}$  inches, and  $\frac{1}{2}$  inch thick.

For the front panel (C), use Plexiglas 5 $\frac{1}{2} \times$  10 $\frac{7}{8}$  inches, and  $\frac{3}{8}$  inch thick. First score deep grooves into panel with pointed instrument. Grooves are in square pattern on  $\frac{7}{8}$  inch centers starting  $\frac{1}{8}$  inch away from edge on all sides. Then drill 35 holes  $\frac{1}{2}$  inch diameter, with centers at crossmarks of scores 2, 3, 4, 5, 6 with 9, 10, 11, 12, 13, 14, 15. These will form the soundgrill in front of loud speaker.

Drill four holes  $\frac{3}{32}$  inch diameter at corners where scores 1 and 7 cross scores 8 and 20 and countersink them. These will be the points where front panel is fastened to cabinet by means of ovalhead woodscrews.

Next drill one large hole 1 $\frac{9}{16}$  inch diameter with center at crossing of groove 17 and groove 4. This will be the window for the revolving dial. Numerals will register against plastic marker strip 1/16 inch wide and  $\frac{3}{8}$  inch



Cabinet with dial knobs and plastic panel removed, showing receiver and speaker units in place.



tween the 2 side panels (A). Corner rails should be dowelled into the sides. After you take the cabinet out of the clamps, you sand it carefully all around and finish it in any desired natural wood or enamel finish.

Next you build in your receiver unit. First, fasten the antenna on the back panel by means of screws and distance-bushings. The chassis is simply put in and braced against side by tiny wedge-blocks. The speaker is mounted on small

blocks fastened to the sides. After all these parts are securely mounted on the inside of the cabinet, you put on the front panel, using an oval-head screw in each corner. Finally, put the two knobs for switching and tuning on the shafts and fasten them by setscrews. Drive rubber-head nails into 4 corners on the bottom and your little radio is ready for operation. It will now give your eyes as well as your ears years of real enjoyment!

## Single Tube Amplifier

Use this amplifier with a crystal set. You'll get excellent loudspeaker reception

**O**PERATION from any 115 volt source, either AC or DC makes this amplifier adaptable to practically any location where commercial power is available. Volume is sufficient to be comfortable in a small room and while the quality cannot compare with that of a large radio, a very favorable comparison may be made with the average AC/DC table model radio currently sold.

The builder of this amplifier will learn a metal chassis construction universally used by radio men and manufacturers. While wooden base construction (commonly called breadboard construction) gives the experimenter an opportunity to mount parts easily, chassis construction has the advantage of neatness, compactness and safety. In a chassis, all of the wiring is concealed beneath the chassis and there is no danger of physical contact with high voltages.

### Meet the Circuit

Nothing unusual is claimed for the circuit of the amplifier. The tube, however, has the advantage of incorporating two tubes in one glass envelope. One of these tubes acts as a rectifier for the plate voltage of the amplifier and the other is the pentode amplifier tube itself. Several of these tubes have appeared on the market in the past few years all of which have the same approximate characteristics but differ only in two respects—filament voltage and base pin arrangement.

Line voltage enters the unit from the line cord where a resistance built into the line cord drops the 117 volt line to 70 volts for the filament. The full line voltage is put on the plate of the rectifier section of the tube

By ADOLPH SUCHY

Electronics Engineer

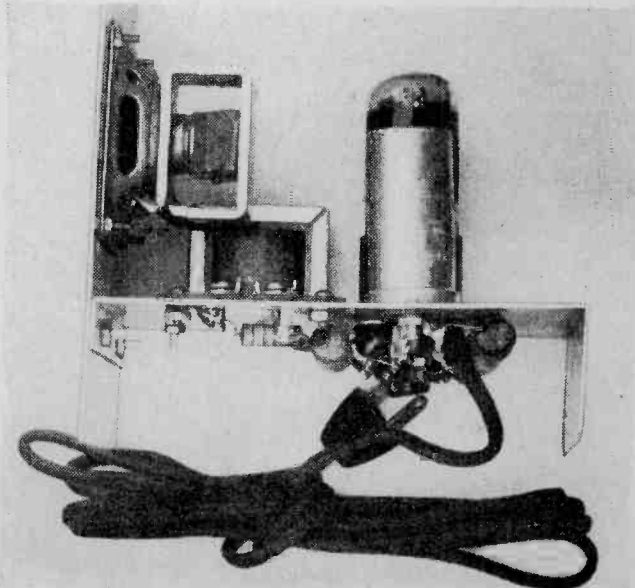
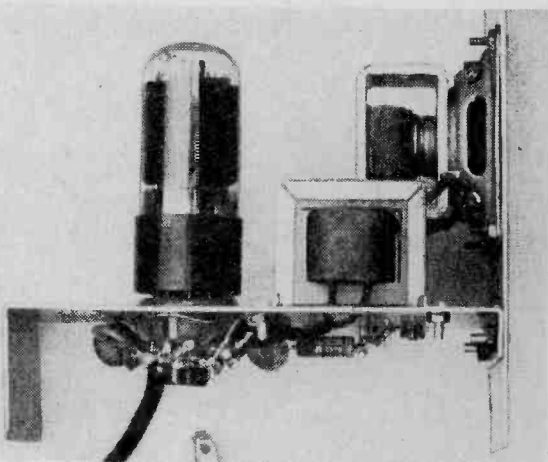

Side views of completely assembled amplifier.

## LIST OF MATERIALS

- 1—310 ohm line cord resistor
  - 1—piece 16 gauge aluminum  $4\frac{1}{4}'' \times 5\frac{1}{2}''$  (front panel)
  - 1—piece 16 aluminum  $4\frac{1}{4}'' \times 7\frac{1}{4}''$  (chassis)
  - 1—2" permanent magnet dynamic speaker
  - 1—midget output transformer to match plate of 70L7 to speaker
  - 1—Dual 20 mfd. 200 volt fabricated plate electrolytic condenser
  - 1—.02 mfd. 400 volt paper condenser
  - 1—5 mfd. 35 volt electrolytic condenser
  - 1—500 ohm  $\frac{1}{2}$  watt carbon resistor
  - 1—2500 ohm  $\frac{1}{2}$  watt carbon resistor
  - 1—500,000 ohm  $\frac{1}{2}$  watt carbon resistor
  - 1—clip type socket
  - 1—screw type terminal strip (2 terminals)
- Screws, nuts, wire, solder  
1—70L7 vacuum tube

and smoothed out by a filter to pure DC for the plate voltage of the amplifier section. The amplifier is biased by a cathode resistance; voltage drop across this resistance causes the grid to be biased negatively. The input circuit is fixed. Although in higher output amplifiers it's a good idea to incorporate a volume control, it is inadvisable in this circuit; such an addition would serve only to complicate the construction.

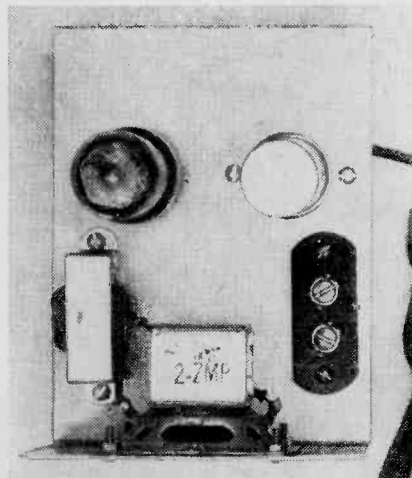
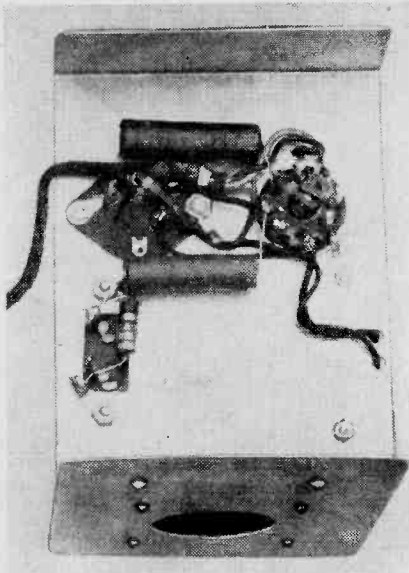

Underneath view (above) and top view (below) of amplifier components assembled to home-made chassis.

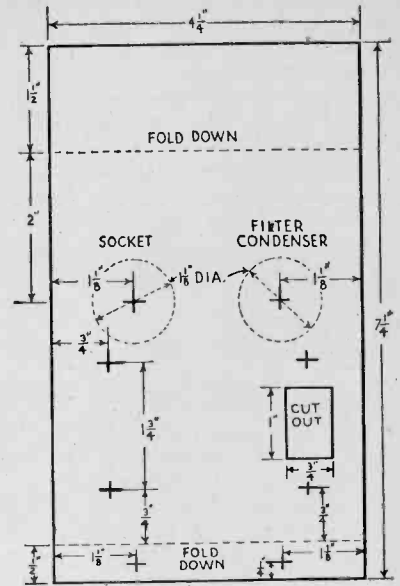

CHASSIS

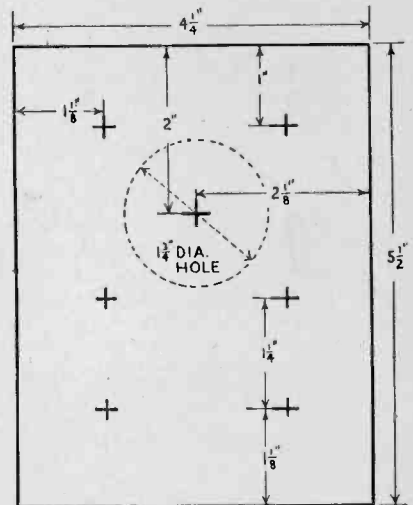

FRONT PANEL

or "fabricated plate" variety. A mounting plate, secured to the chassis by two machine screws, comes with this condenser. To mount this plate punch a socket hole in the chassis of the right size.

The output transformer is of the midget variety and matches the impedance of the amplifier tube (2000 ohms) to the impedance of the speaker voice coil (2 ohms). The resistance line cord has three wires. Two come directly from the plug and the third comes from the built-in

resistance connected to the line at the plug end of the cord. In operation this cord may become quite warm but the unit is built to dissipate heat caused by the voltage dropping across it. The resistors are  $\frac{1}{2}$  watt carbon resistors, color coded and insulated. The input terminal strip is similar to the strip used in the crystal set described in the October '46 SCIENCE AND MECHANICS.

It is advisable to procure all the parts before construction is started inasmuch as the individual layout may differ somewhat depending on the parts purchased. A template is then made for the panel and the chassis. Make this template of brown wrapping paper, plotting each of the holes to be drilled or punched by checking with Figs. 2 and 3 and measuring each part to be sure that the mounting holes correspond. After the template has been made and checked, center punch each hole and drill with a No. 27 drill. Some of the holes will have to be enlarged later by larger drills or socket punches. The square hole to accommodate the input terminal strip is now made by drilling two  $\frac{3}{8}$  inch holes far enough apart to allow the terminals to pass

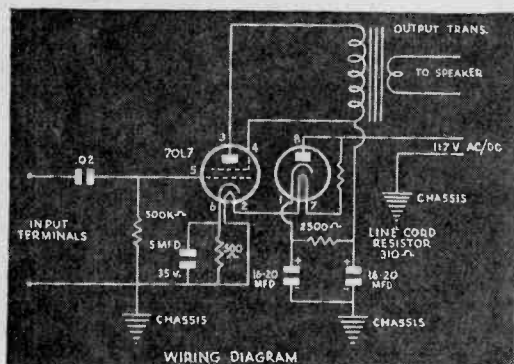

through, then sawing the metal between them with a keyhole saw. The hole is then filed sufficiently large so that no part of the terminal touches the metal chassis.

It is important that these terminals be kept away from the chassis itself because grounding to the chassis may make the amplifier inoperative. The socket hole and condenser mounting hole are now punched or drilled. If any radio construction is contemplated the constructor may well invest in a socket punch. This simple device will save endless work and does a neat and accurate job. The usual size is  $1\frac{1}{8}$  inches. If a socket punch is not available the holes may be cut out with a circle cutter or enlarged from a  $\frac{3}{8}$  inch hole with a pipe reamer. The speaker hole was enlarged from a socket punch hole with a pipe reamer. After all of the holes are drilled the chassis is bent. This is done by putting the metal into a vise between two pieces of wood and carefully bending along the scored line. Parts are mounted and the chassis attached to the panel. Now you are ready for wiring.

The wiring diagram (Fig. 4) and the picture of the under side of the chassis (Fig. 5) show the electrical connections and the physical layout of the wiring. All octal base tubes have numbered pins and the numbers around the tube in the diagram correspond to the base pin numbers of the tube. Frequently molded sockets have numbers moulded into the socket adjacent to the pins to which they correspond. These base numbers are always read by looking at the socket from the *bottom*. The numbers are then read clockwise from the keyway starting with number 1 and continuing around to number 8.

1. Connect the secondary (solid wire) to the two terminals of the speaker voice coil.

2. The line cord is secured to the chassis by a lug that is bent over the end of the cord. Three leads come from this cord. The red lead is grounded. The black lead goes to number 8 on the socket. The resistor lead is connected to number 7 on the tube socket.

3. Number 2 pin on the socket is grounded to the chassis.

4. A 500 ohm resistor is connected across the ends of the 5 mfd. 35 volt condenser and the plus end of the condenser is connected to number 6 pin of the tube socket. The other end of the condenser-resistor combination is grounded to the chassis.

5. The common negative of the filter condenser is grounded.

6. A 2500 ohm resistor is now connected to the two positive terminals of the filter condenser, one end of the resistor to each of the terminals.

7. A wire is now connected to one of the positive terminals of the filter condenser mentioned in 6. The other end of this wire is connected to pin number 4 of the tube socket, also to the one wire of primary of the output transformer.

8. The other positive terminal of the filter is connected to pin number 1 of the tube socket.

9. The other end of the primary of the output transformer is connected to number 3 pin of the socket.

10. The .02 mfd. condenser is now wired from number 5 pin of the socket to one of the input terminals.

11. A 500,000 ohm resistor is now wired across the input terminal strip. The terminal opposite the one which has condenser connected to it, is grounded.

This completes the wiring of the amplifier. A 70L7 tube is now inserted into the socket and the wiring checked. Make sure that all connections are correct according to the diagram and steps given above. After checking, a phono pick-up or the crystal set described in the last issue is connected to the input terminals of the amplifier and the plug inserted into the electric light socket. About thirty seconds should be allowed for a warm up period before the amplifier will operate. The constructor may substitute a dual screw type terminal strip for the phone tip type on the crystal set. This will facilitate connecting the amplifier to the set.





## Precision Electronic Timer

by 5½ inches. The chassis is laid out as shown in the pictorial diagram and illustration. The arrangement of the components is not critical and the only precaution necessary is to be sure the tube guide slots face in the direction shown in the pictorial diagram.

When wiring, either the pictorial or schematic diagram may be used. The pictorial is preferred for it shows the exact placement of wires and parts. Wire the filament circuit before wiring resistors, condensers, etc. Work slowly, checking each

Try this versatile unit for photo printing, experimenting,  
or making flasher displays

By MILO A. ADLER

Technical Staff, Allied Radio Corporation

**S**IMPLICITY, dependability, and the ability to maintain accuracy after calibration were the three main factors considered when designing this electronic timer. The circuit is not complex and the number of components has been kept at a minimum. This timer will give accurate timing intervals in ranges from less than one second to over sixty seconds, regardless of line voltage variations, over the extremely wide range of 90 to 130 volts.

The plate relay used has double-pole double-throw contacts that are independent of the internal circuit of the timer. This versatile switching arrangement enables the builder of this unit to find countless applications for this timer. The experimenter may use the timer to accurately time the "on" or "off" period of an electrical device. The photographer may use it for accurately timing the exposure of photographic prints. Two of these units may be connected together for use in a flasher system where it is desired to regulate the duration of the "on" and "off" period of a window display or sign.

Parts needed may be purchased as a completely packaged kit, or separately. Special components are not used and all parts are standard units made by reputable manufacturers. The chassis used for the model shown in the illustration is 6 x 5 x 2 inches, and the panel is 6½

connection as it is made. An extra few minutes spent in careful wiring and thorough checking may save hours of trouble-shooting later. Be sure that the polarity of the electrolytic capacitor

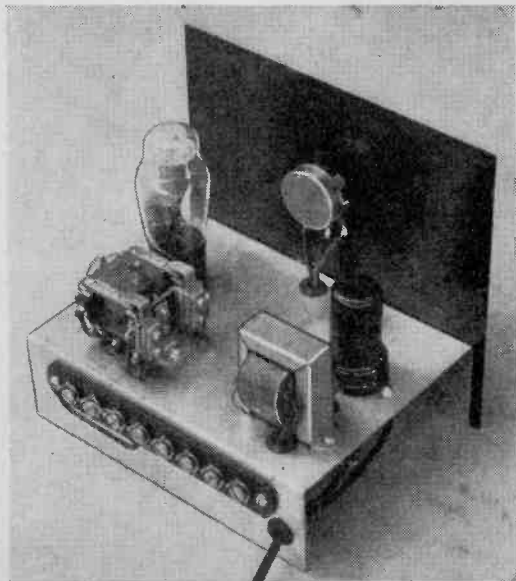

Rear view showing wire jumpers for automatic shutoff.

is observed when wiring it across the relay. The negative side must be connected to the plate of the 2050 tube. The right and left hand terminals of the timing control potentiometer may be determined by viewing the control from the back with the terminals pointing downward.

After the timer has been completely wired and the tubes inserted, the unit is ready for operation. The timer operates on 90 to 130 volts, 50 to 60 cycle ac only. The double-pole double-throw relay, as previously stated, permits the control of a large variety of circuits and of more than one unit at a time. To time the operation of any electrical device not drawing more than 800 watts from a 110 volt line, connect terminals 3 and 4 (or 6 and 7) in series with the device and the current source. Turn the power switch "On" and allow about one minute for the tubes to warm up. To start a timing cycle (the period of time for which the timer is activated), turn the timer switch "On." There will be a slight time lag of approximately one second; then the relay will close and the apparatus will operate until the timing cycle is completed. The timer switch must be left on for the duration of the cycle. If the switch is turned "Off" before the cycle is complete, the timing operation will stop. When the timing cycle is completed, the relay opens and current flowing to the device being operated is stopped. The switch may then be turned off, and the timer will be ready for a new cycle. To time an "Off" period for an electrical device that is normally on, connect terminals 4 and 5 (or 7 and 8) in series with the device and the current source. A remote switch, if desired, can be connected to terminals 1 and

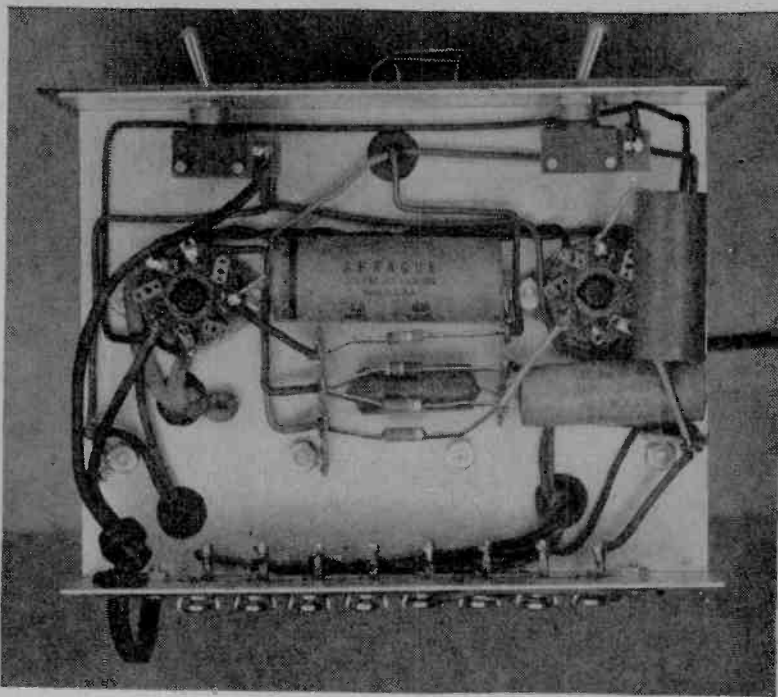

Underneath view showing components of the timer.

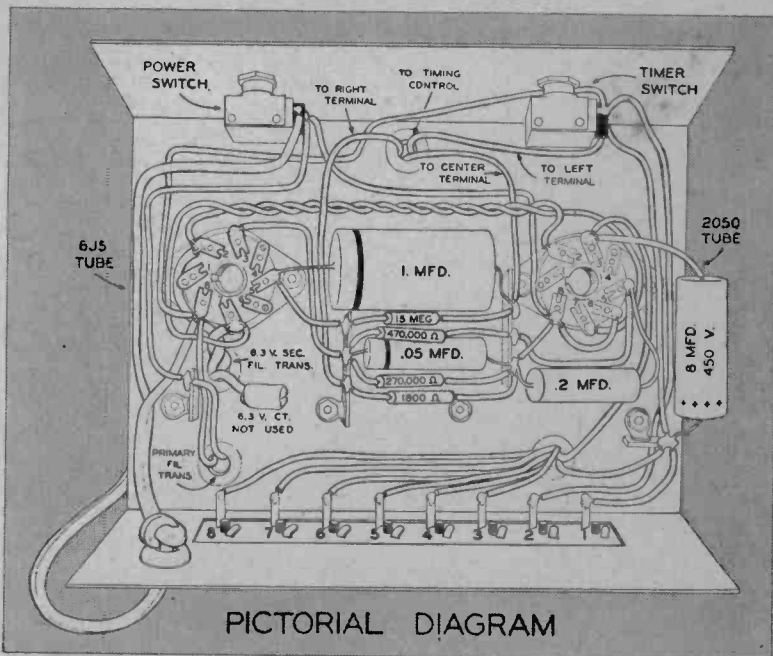

2 on the terminal strip. If this remote switch is a momentary push-button type, connect terminals 1 to 3, and 2 to 4 with wire jumpers. Then it is only necessary to depress the push button until the relay closes. The switch may then be released and the timing cycle will complete itself.

The duration of the timing cycle is dependent



voltage is applied to the 2050 thyratron tube. Therefore no plate current will flow and the timing relay will stay open. At the same time the grid and cathode of the 6J5 tube act as a diode, charging up the 1 mfd. condenser in the grid circuit of the 6J5.

When the *timing switch* is closed the charge on the 1 mfd. condenser biases the 6J5 beyond the cutoff point, and no plate current flows through the tube and the 270,000 ohm plate load resistor. With no current flowing through this resistor no bias is applied to the 2050 tube and the tube conducts plate current which also flows through the timing relay and closes it.

The setting of the *timing control* determines the point at which the charge on the 1 mfd condenser no longer biases the 6J5 to cut-off. As the 1 mfd condenser discharges through the 15 megohm resistor in parallel with it the voltage across the condenser gradually decreases until this voltage is approximately equal to the voltage between the center arm and bottom end of the *timing control*. At this point the 6J5 tube conducts plate current which flows through the 270,000 ohm resistor. The resulting voltage drop across this resistor is applied as a negative bias on the grid of the 2050 thyratron tube.

The plate voltage applied to the 2050 is pulsating dc and the dc bias which has been applied to the grid of this tube stops the plate current flow. With the 2050 plate current flow stopped the timing relay is deactivated and it opens to complete the timing cycle. This process is repeated when the *timing switch* is opened and again closed for another timing cycle.

### Inductance Test

• Inductance, or electrical inertia, can be illustrated by attaching one end of a long piece of insulated wire to one pole of a dry cell and touching the other end momentarily to the other post. A feeble flash results. Now wind the wire

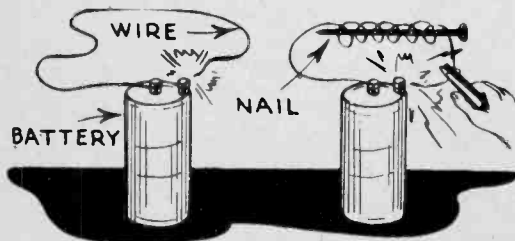

around a nail and attach free end to a wood pencil or clothes pin (for insulation). Again strike wire on the battery post. Notice flash when "breaking" circuit. Current, much like a flywheel wants to keep on going; it resists change by having lines of force cut many turns of wire, inducing a much stronger electromotive force than the battery's feeble 1.5 volts. The single stretch of wire has no turns which permit an additive effect, nor does it have the iron core to concentrate the magnetic field.—FRED E. EBEL.

## Hear Flies Walking With 20-MINUTE MIKE

RADIO speech microphones are sensitive and costly. Here's a fine substitute equally as sensitive under ideal conditions but having a cost of approximately zero. The sensitive unit

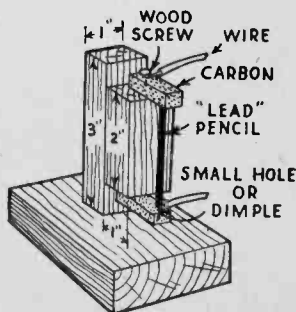
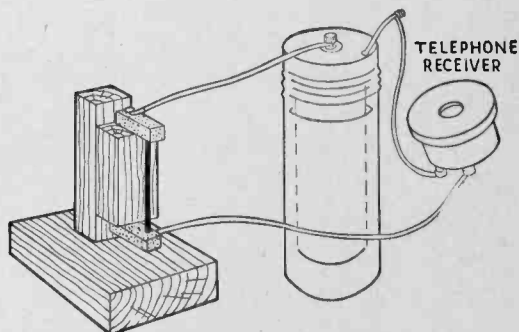
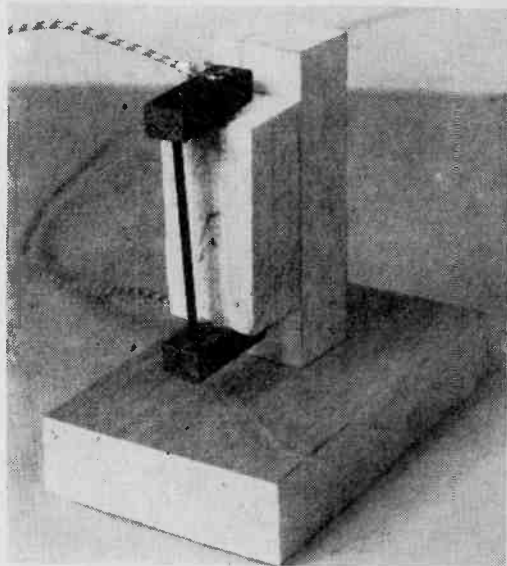

is merely a combination of two carbon blocks and a two-inch length of graphite rod taken from a lead pencil. When properly mounted and used with a pair of earphones and a single dry cell, such a microphone will detect the footstep of a

fly that may be walking over it. When placed on a wall, people talking in the next room may be very clearly heard.

The carbon block may be sawed from an old dry cell carbon. A dimple is drilled in each end so that the sharpened ends of the graphite rod will rest loosely therein. The graphite rod must be free to move. Otherwise the gadget would not be sensitive to the footfall of an elephant.

The microphone is connected in series with a dry cell and a pair of radio phones. A two or

three thousand ohm rheostat may help to adjust for the right amount of current that will deliver maximum sensitivity. Sometimes if you wish to amplify sounds coming from a certain direction, a small oblong piece of lightweight paper may be glued to the graphite rod and the paper faced in the direction from which the sound to be caught comes.—RAYMOND F. YATES.

# Loudspeaker CRYSTAL RECEIVER

By T. A. BLANCHARD  
Electronics Engineer



SOME years ago a Phoenix, Ariz., reader wrote us that he used a crystal radio as a musical clock. The loudspeaker brought in a local broadcaster; but with headphones and with the local station off the air, all the powerful west coast stations came in. Using this information L. J. Markus planned a set which is still bringing in letters.

At the request of the editors, I have modernized the original set to some extent by employing a germanium rectifier instead of the original galena crystal detector. I have also introduced certain mechanical and design changes so that all controls are on the front panel. Finally, since even the best crystal set is limited in scope, we added a miniature pentode vacuum tube to really give the set some kick. Yet, despite these changes, basic Markus crystal circuit remains unchanged.

The loudspeaker crystal set pictured here has been designed so that the constructor may disconnect the battery-powered amplifier by a flip

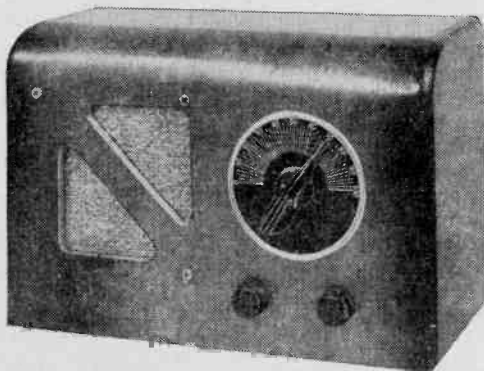

Front view of loudspeaker crystal set. It is housed in standard wooden cabinet of the type used for miniature electric sets. Case measures 9¼" wide, 4¼" deep, and 6" high.

of the switch. In actual tests, this set received local and New York City stations in Connecticut with crystal detector only. Changing the speaker connections over to the amplifier, the signal was really good—and from only one tube!

The outward appearance of this set is similar to any small table model radio. The cabinet used was one of many varieties on the market. Because it is not always possible to duplicate ours exactly, we suggest that you make the set chassis *after* the cabinet is obtained. In this instance, the chassis was formed from a piece of aluminum 7¼ inches by 4¼ inches. Measuring in 1½ inches from each end, the panel was bent at right angles

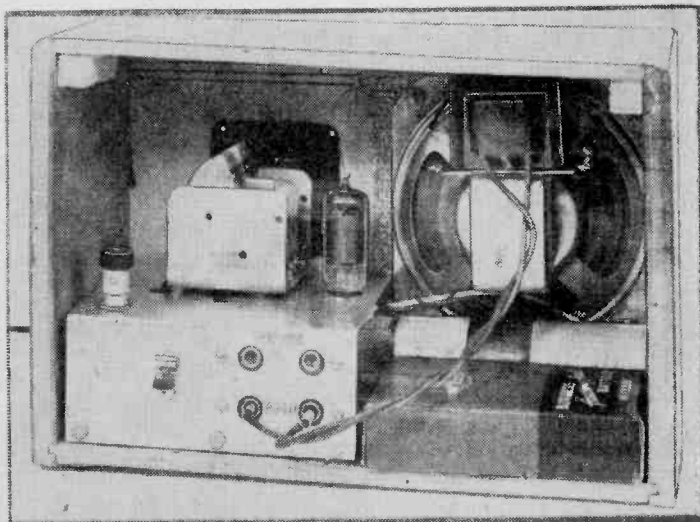

Rear view of loudspeaker crystal set with chassis and PM speaker installed. There is still ample room for placing A and B batteries inside the cabinet.



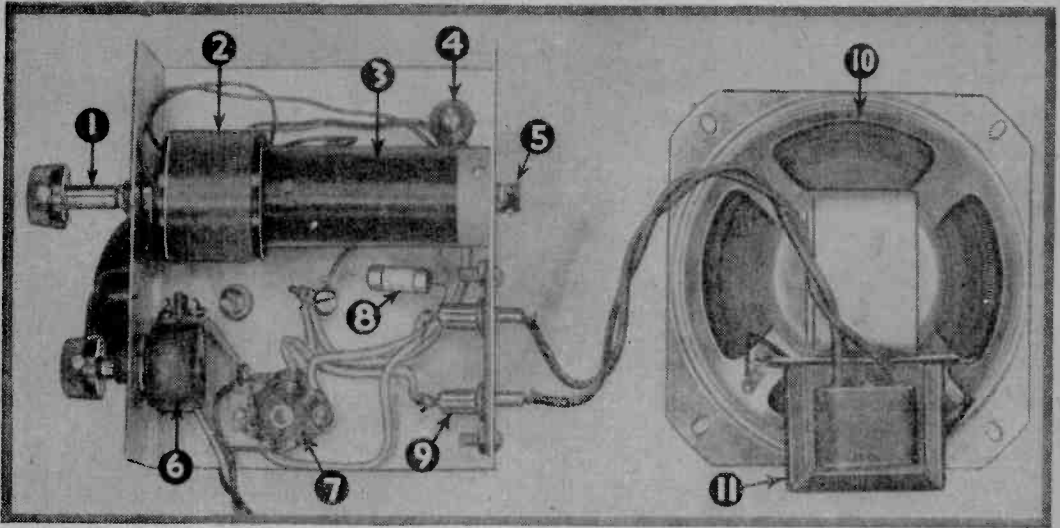

Bottom view of loudspeaker crystal set, with parts marked for easy identification. PM speaker and output transformer are at right.

to form the aprons. These dimensions, as well as location of the mounting holes ( $\frac{3}{8}$  inch) for battery switch and selectivity control, will depend upon the particular cabinet selected. The constructor can, however, feel free to modify his design to any extent for so long as components are wired according to pictorial layout shown. Results should be as good as ours. It will also be noted that the chassis occupies only half of the available space in the cabinet, thus leaving ample room for the loudspeaker and auxiliary battery power. A  $1\frac{1}{2}$  volt cell and 45 volt hearing aid B battery will fit nicely.

With the exception of the coils (L1 and L2) the set is based on standard parts. The coils are homemade. Coil L1 is wound on a Bakelite

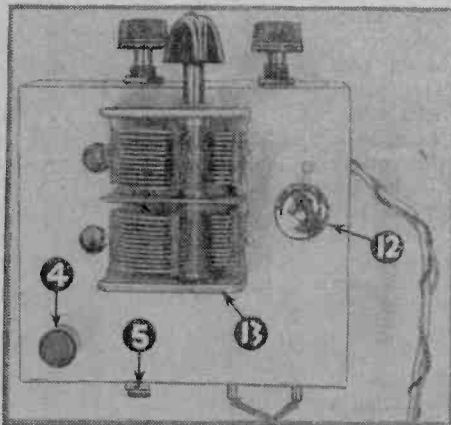

Looking down on set. Chassis, formed from light aluminum, measures  $4\frac{1}{4}$ " wide,  $3\frac{3}{4}$ " deep,  $1\frac{1}{4}$ " high.

KEY

- 1—Plunger shaft
- 2—Coil L-1 wound on old tube base
- 3—Coil L-2
- 4—Antenna post
- 5—Ground clip
- 6—Battery clip
- 7—Tube socket
- 8—Germanium detector
- 9—Phone and speaker jacks
- 10—4" PM speaker
- 11—25,000 ohm output transformer
- 12—1L4 tube
- 13—2-gang condenser

radio tube base of the large type. The bulb is broken from an old tube, and the remaining contents are scraped out with a penknife. The prongs are cut off, a hole drilled in the center of the base for attaching a  $\frac{1}{4}$ -inch metal or wood rod. Drill a small hole in each end of the tube base, large enough to admit No. 30 enameled magnet wire. Wind an even layer of wire on the tube base from end to end. The start and finish of this coil may be threaded through the portion of the prong ferrules in the base.

Flexible leads are soldered to the ends of the above coil leads. Coil L1 may be set aside now, and L2 started. For the latter, a 1-inch diameter tube, 3 inches long is used. Starting about  $\frac{1}{4}$  inch from one end of this tube, wind an even layer of No. 30 enameled magnet wire the entire length of the coil form, stopping about  $\frac{1}{8}$  inch from the end. Both ends of the form are pierced so that wire may be secured firmly. To further prevent coils from working loose, they may be doped with clear duco or shellac.

In mounting these coils remember that the object is to allow the coupling between L1 and L2 to be varied. The larger coil is mounted to

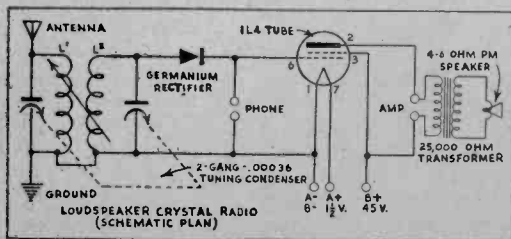

## LIST OF MATERIALS—LOUDSPEAKER CRYSTAL RADIO

1—set of coils described in text  
 1—2-gang TRF tuning condenser, approx. .00036 mf  
 1—Germanium rectifier or similar detector unit  
 1—7 prong miniature tube socket  
 1—miniature tube type 1L4 (or 1T4)  
 2—double phone jacks  
 1—SPST battery switch  
 1—dial plate  
 1—bar type pointer knob  
 2—small round knobs  
 1—1½ volt A battery  
 1—45 volt miniature B battery  
 1—25,000 ohm output transformer  
 1—4" PM type speaker  
 1—cabinet, purchased or made to fit set  
 Hook-up wire and miscellaneous hardware

the rear chassis apron in a fixed position. The smaller coil on the tube base slides over the end of the larger coil. Having a plunger rod attached to it, control is thus possible from the left front knob on the set. To provide the smoothest action, the plunger rod passes through a bushing inserted in the lefthand 3/8-inch chassis hole. The plunger rod may be oiled lightly.

Four more 3/8-inch holes are cut in the rear chassis apron for phone tip jacks. The uppermost jacks are marked "phone." When either speaker or earphones are connected here, your set is working on "air power" and the battery switch at right should be off. To spark-plug the initial signal from the Germanium rectifier, pull out phones or speaker, and plug into jacks marked "amp"; then turn on battery switch.

The speaker is a regular 4-inch PM speaker with a substantial Alnico slug. Because this speaker must be driven by feeble crystal signals, a good quality high resistance output transformer must be used. We advise a transformer with a 25,000 ohm primary with secondary to match a 4-to-6 ohm PM voice coil.

The circuit is arranged so that only the crystal detector may be built if desired. Wire in all components up to the phone jacks, leaving out

battery switch, amplifier jack, and tube socket. The heavy line in the wiring plan represents the common ground circuit. When set is built on a metal chassis, components may be grounded directly to chassis, thus minimizing the amount of wiring required. To identify tube socket pins, note that space between pins marked 1 and 7 on pictorial plan is wider than the spaces between the other pins. With socket in position shown, the pins are read in clockwise direction, starting with pin 1 at upper right.

The success of any crystal radio will depend upon a good antenna and ground. The longer the antenna the better. A firm ground connection is also required. However, during tests we operated the set with antenna only with surprising results. We do not guarantee groundless operation to be effective in all localities, however. The set is tuned with a single dial control. Where stations come in together, slide the coupling plunger in or out and return to the desired station. While the coils described do a good job in covering all of the broadcast band, those in areas served only by stations below 1300 kc may achieve better reception by removing a few turns from the end of coil L2.

## Twin-Lead Standoff Insulators

• Good looking and highly efficient standoff insulators can be easily and cheaply made for bringing that polyethylene twin-lead down from the television or FM di-pole on the roof. Besides being good insulators, the standoffs hold the twin-lead securely and keep it from swaying and slapping the side of the house in windy weather. Insulators will hold any size twin-lead from 75 to 300 ohms. Sketches give most of the details.

Fig. 2 shows constructional details. Saw 1 in. deep slot round polystyrene rod 1/2 in. dia. and 4 in. long with a hack-saw; then file to correct width with a thin flat file. Twin-lead should fit snug in slot before the screw is tightened. Those

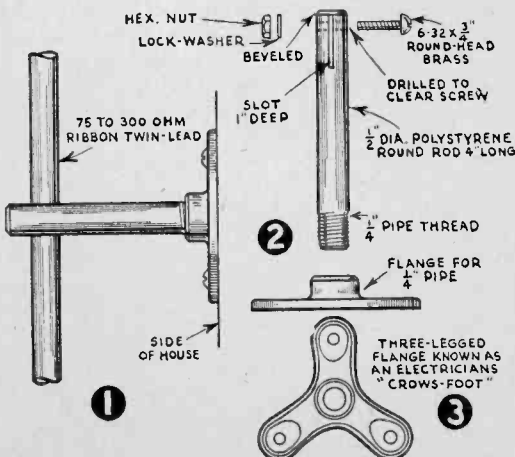
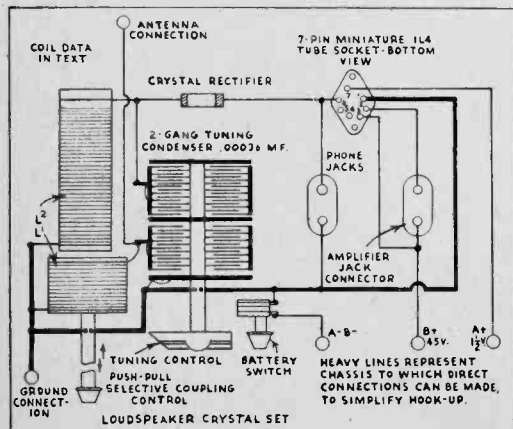

not having a 1/4-pipe die can borrow one or else have the polystyrene rods threaded in a plumbing shop at little cost. Polystyrene rod threads easily and cleanly.

Fig. 3 shows a "crows-foot" used by electricians for fastening fixtures, which can be used

instead of flat flanges if desired. For a fancy job, obtain chrome-plated flanges at a plumbing and heating concern.

Fig. 1 shows the completed standoff insulator fastened to the side of the house.—ARTHUR TRAUFFER.



# Easy-To-Build Home Broadcaster

Try building this phono-oscillator. It is capable of 100 percent modulation

By MILO ADLER

Technical Staff, Allied Radio Corporation

**T**HIS *Home Broadcaster* is a wireless phono-oscillator which permits the playing of phonograph records or the making of "radio" announcements through your radio set without the necessity of direct connection to the radio set itself. It can be used at any distance up to 25 feet from your receiver.

A phono-oscillator is really a "miniature broadcast station" which may be operated legally only because of its relatively low power and limited range. The unit described here is capable of 100% modulation, a feature not usually found in phono-oscillators. Operation, particularly of oscillation, is the function produced by

the 35L6GT tube. The oscillator coil has a primary and a secondary winding. The primary is in the cathode circuit and the secondary is in the plate circuit of the 35L6GT. The cathode, grid number 1, and plate are involved to produce oscillation. Grid number 2 is modulated by a phono-pickup. Since this grid is in the path of the electron stream it modulates or causes changes in the flow of electrons from the cathode to the plate.

Parts to build this unit may

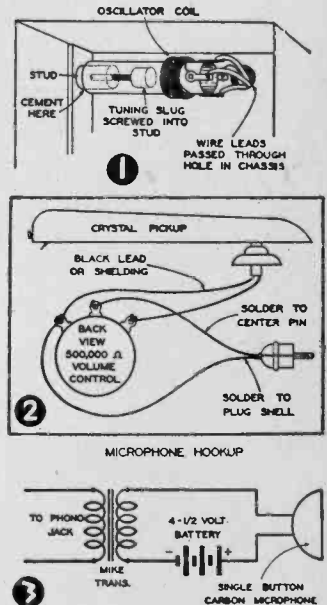

be purchased as a completely packaged kit, or separately. To assemble, mount all components as shown in the pictorial diagram. The location of parts has been carefully planned so that all leads will be short and direct, and the entire unit will be very compact. Resistors and paper condensers are supported by their own pigtail leads at the time of wiring.

The punched chassis base is assembled to the case first, with the long turned-up lip on the chassis facing the front of the case. Mount the tube sockets from underneath the chassis. Be sure the tube guide slots face in the direction shown in the pictorial diagram. Next mount the

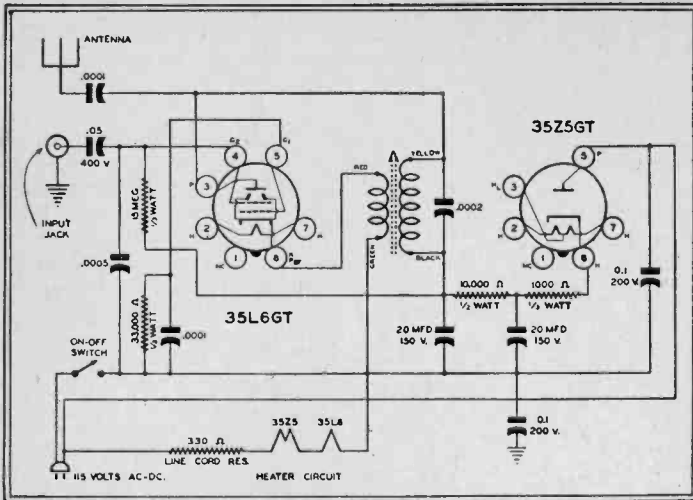

Schematic diagram of phono-oscillator.

end of the coil cemented to the mounting stud. Allow the cement sufficient time to dry thoroughly before moving the wires that extend through the chassis (Fig. 1).

Study diagrams very carefully before wiring. Either pictorial or schematic diagram may be followed, although the pictorial is preferred, for it shows the exact placement of wires and parts. All connections should be securely soldered, using only rosin core solder. Acid core solder or acid flux should never be used because of the probability of corrosion. Hold tip of soldering iron against wire and terminal for a few seconds before

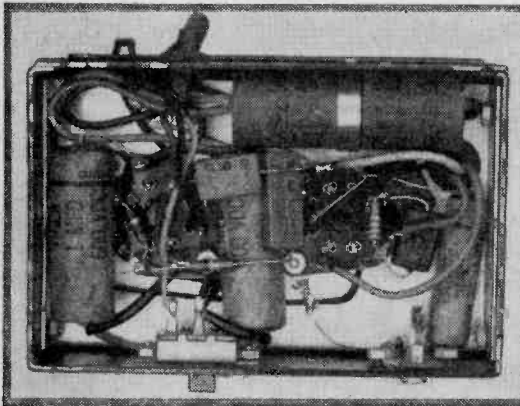

Underneath view with bottom removed.

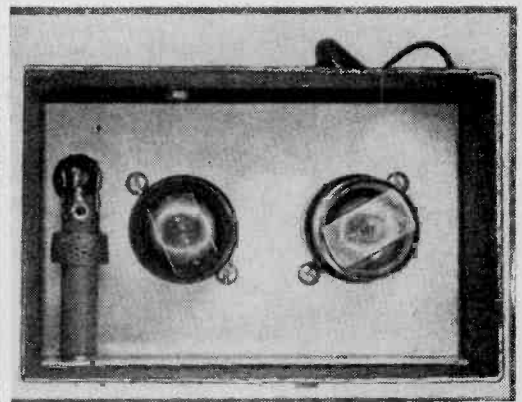

Top view, showing tube positions.

phono input jack, on-off switch, line cord lock, and electrolytic condenser. Note that the electrolytic condenser mounts against the back of the case, with the mounting strap passing through the opening between the chassis edge and the case.

Next install the oscillator tuning slug into the holding stud (already attached to the ready-made case). Screw the slug several turns into the stud from the inside of the case. The wire leads from the oscillator coil should then be passed through the hole provided for them, and the opposite

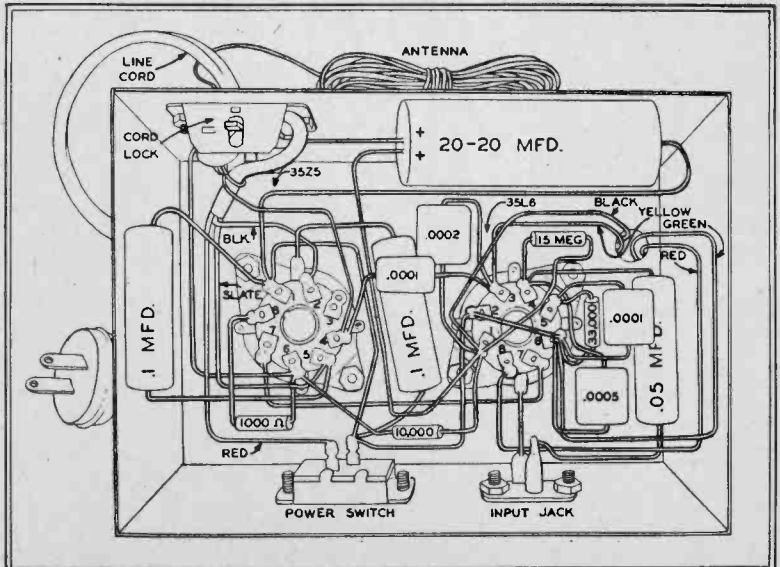

Pictorial diagram of phono-oscillator.

applying solder, then apply solder where tip of iron meets work. Use just enough solder to cover connections and fill the crevices between wires. Remove iron, but do not move wires until solder has set. This requires only a few seconds. Work slowly, checking each connection as it is made. Mark either the schematic or pictorial diagram with a colored pencil as each connection is completed. When more than one wire is to be connected to a particular point, do not solder until all wires are installed at that point. An extra few minutes spent in careful wiring and thorough checking may save hours of trouble-shooting later.

When wiring is completed, connect a crystal or other high impedance phonograph pickup to the plug, soldering the black lead or shielding (whichever is provided on your pickup) to the

---



---

#### LIST OF MATERIALS

- 1—35L6GT/G tube
  - 1—35Z5GT/G tube
  - 1—1,000 ohm ½ watt carbon resistor
  - 1—10,000 ohm ½ watt carbon resistor
  - 1—33,000 ohm ½ watt carbon resistor
  - 1—15 megohm ½ watt carbon resistor
  - 1—20-20 mfd. 150 V. electrolytic condenser
  - 2—.1 mfd. paper tubular condensers
  - 1—.05 mfd. paper tubular condenser
  - 1—.0005 mica condenser
  - 1—.0002 mica condenser
  - 2—.0001 mica condensers
  - 1—punched and formed chassis, with case (Allied Radio 55-537)
  - 2—Octal tube sockets
  - 1—oscillator coil (Allied Radio 55-535)
  - 1—on-off switch
  - 1—330 ohm line cord with plug
  - 1—cord lock
  - 1—shielded phono input plug
  - 1—phono input jack
  - Miscellaneous hardware, wire, and solder
- 
- 

shell of the plug, and the other lead to the center pin. When a high output pickup (0.7 volts or higher) is used, a 500,000 ohm volume control must be connected as shown in Fig. 2.

The phono oscillator acts as a small transmitting station which can be tuned in on your radio set. It can be adjusted to operate at any dial setting from 540 to 700 KC. To make this adjustment proceed as follows: 1. Carefully tune receiver from 540 to 700 KC to find a dial setting where no radio station is heard; 2. Place oscillator in operation by pushing slide switch to on position. Allow unit two or three minutes to warm up; 3. Uncoil antenna to a length of 10 feet; 4. Place phonograph in operation by turning motor on and setting pickup arm on the record, with pickup volume control adjusted to approximately center position; 5. Using a small screwdriver, tune oscillator coil, through opening in case, until record can be heard through the radio; 6. Tune radio to a local station and note volume of music being played. If your radio has a magic eye or tuning indicator select

a station with a signal strength about the same as that of the "wireless" oscillator, when it is tuned in. With the radio again tuned to the oscillator signal adjust pickup volume control to position which gives you about the same volume from oscillator signal as you had from local station. The pickup volume control should be left at this setting permanently, and all future control of volume made at the radio set.

If microphone operation is desired, any single-button carbon mike may be used. A suitable microphone transformer and a 4½ volt battery are employed in a standard circuit, the secondary of the mike transformer being connected to the phono input plug as shown in Fig. 3. If your radio has push button tuning, a push button may be adjusted to the signal of the phono oscillator in the same manner as you would adjust a button for a radio station. If phono oscillator is placed at a greater distance from the radio, it may be necessary to use more antenna wire. With sufficient antenna at the oscillator, background noise is minimized. As additional antenna is uncoiled, some change in tuning may take place, necessitating readjustment of the phono oscillator tuning control or of the radio. Always adjust the radio set for the maximum deflection of the tuning indicator or until the record is heard clearly and with a minimum of noise. If there is a "howl" or "whistle" in the radio while records are being played, the frequency at which the phono oscillator is "transmitting" is too close to that of a broadcast station, and it will be necessary to set the receiver dial at a different position and readjust the tuning control on the phono oscillator to obtain this new setting.

If excessive hum is present in your radio when tuned to the phono oscillator (with no record playing) reverse the plug of the oscillator in the power outlet or socket. If hum persists, reverse power cord plugs on radio and phonograph, one at a time. But remember, do not attempt any service operation until line cord plug is removed from power outlet.

### A Safe Connection

- When making a wire connection for our radio, I cut two one-inch pieces from a half-inch rubber tube. I split these and put one around

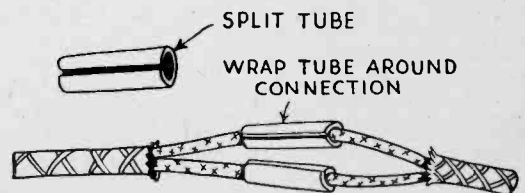

each wire at the connection point. Then I wrapped some tape over all, and it made a neat, safe job.—FRED CORNELIUS.



# ELECTRONIC TIMER

## Now You Can Split Seconds

By THOMAS A. BLANCHARD

Electronics Engineer

**F**EW projects in the field of electronics have the general appeal to all experimenters as do timing devices which operate without benefit of moving parts. In industry, electronic timers are already widely used in the control of precision operations where a motor-driven timer would be much too sluggish to time short interval operations.

Unlike mechanical timers, which depend upon various gear escapements, the electronic timer depends merely upon a vacuum tube and the charging or discharging of a condenser in the grid bias system to control the time cycle. Without question, the timer described here is simple enough for beginning radio experimenters to duplicate with success. More important, few parts are required in construction—all generally available, including tubes, since any one of several low current-low voltage tubes may be employed. However, the constructor is not limited to one of the pentodes suggested in the schematic. Actually the pentode is connected to function as a triode, therefore, any triode such as a 30, 1E4G, 1H4G, 1LE3, 1G4G, etc., may be substituted simply by changing the filament resistors from 600 to 1000 ohms each.

The timer is housed in a 3x4x5 metal box such as stocked by all radio supply houses. The chassis is a simple metal bracket consisting of a 1½ in. diameter hole for mounting an octal wafer socket, and two ½ in. diameter holes; one for mounting the timing condenser and the other for passing wires.

It can be stated here that these physical specifications may be ignored if the constructor has other materials on hand for housing the timer.

As shown in the drawings, the box panel is drilled to accommodate a 10-meg potentiometer, and terminal strip. Also, a suitable hole is drilled in the side of the box, toward the rear, to receive a double pole-single throw toggle switch.

To assemble the chassis: Attach the wafer socket first; then put a strip of bakelite over the adjoining ½-in. hole for mounting the 0.5 mfd. paper condenser. A brass eyelet or lug in the center of this strip provides a convenient mounting for the condenser. One of condenser leads

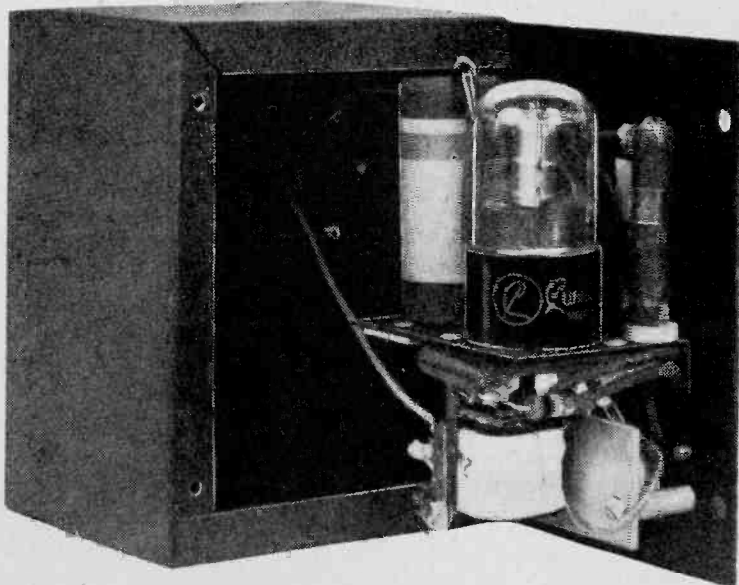

is passed through eyelet and soldered securely.

The filament voltage drop resistors are mounted vertically in each corner of the chassis by means of long 6-32 machine screws. A fiber washer should be placed over each end of the resistor if

ELECTRONIC TIMER—List of Materials

- 1 3x4x5 Metal Box
- 1 Metal chassis (homemade)
- 1 10 meg (or more) potentiometer
- 1 30,000 ohm, 1/2 watt resistor
- 1 50,000 ohm, 1/2 watt resistor
- 2 600 ohm, 10 watt resistors for .1 amp. tubes ohmite (1000 ohm, 10 watt resistors for .06 amp. tubes)
- 1 octal wafer socket
- 1 potentiometer dial plate
- 1 bar knob
- 1 terminal strip
- 1 0.5 mfd. or larger paper condenser
- 1 4 mfd., 150 volt electrolytic condenser
- 1 Pentode or triode tube of the low current type
- Pentodes: (.1 amp. filaments)  
1Q5GT, 1C5GT, 3Q5GT\*, etc.
- Pentodes: (.05 amp. filaments)  
1T5GT, 1A5GT, 1LA4\*, 1LB4\*, 30\*,  
1E4G, 1LE3\*, 1G4GT, 1H4G, 1E4G, etc.

Tubes marked with asterisk (\*) require socket wiring changes. All others interchangeable in circuit.

NOTE: For simplification, pentode in schematic is drawn as a triode. The sup. grid, (prong 4) is tied to plate (prong 3) in all instances. Thus pentodes and triodes may be interchanged without altering wiring.

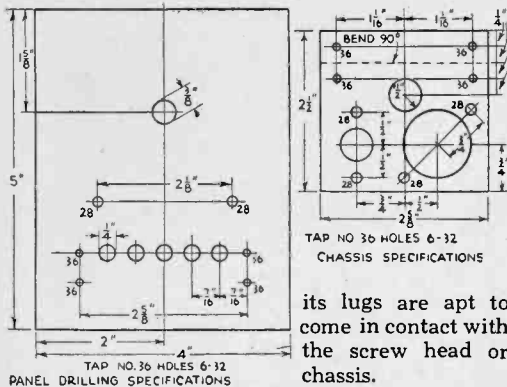

its lugs are apt to come in contact with the screw head or chassis.

The chassis is attached to the panel at this stage. Since the panel carries the terminal strip and potentiometer, the control now stands ready for wiring. Because of the timer's simplicity, no special comments are needed because the drawings show all details. The relay and toggle switch are installed after all other work has been completed.

In the original model, two studs were threaded and screwed directly onto two of the screws projecting from the terminal strip to provide a mounting for the relay. The spacing of these studs is identical to the mountings of several popular relays sold by radio suppliers. However, in the original model, it was necessary to mount the relay on a bakelite strip since its design did not include a mounting bracket.

A D.C. relay of the single pole-double throw type, and having a coil resistance of 2,000 ohms or more, controls the load circuit. A 4 mfd., 150 volt electrolytic condenser is shunted across the coil to eliminate the A.C. in the half-wave recti-

fied current delivered to the relay.

The control is completed by wiring in the relay contacts and d.p.s.t. toggle switch. One half of the toggle switch serves to put positive bias, through a 30,000 ohm resistor, on the grid. The two remaining poles on the toggle switch are wired in series with the normally closed contact of the relay.

When the toggle switch is open, the grid of the tube is negatively biased and the relay does not close. Tripping the toggle switch does two things: First, negative bias is applied, but is retarded in reaching the grid because of the high resistance potentiometer and condenser in the grid circuit. At the instant positive bias is applied, we complete the circuit through the normally closed contact of the relay. This causes the device being timed (photo enlarger, etc.) to come on. After an elapse of time, depending upon the position of the potentiometer adjustment, the grid becomes positive. At that instant, the relay becomes energized, and the timer circuit opens, shutting off the device being timed.

This same timer may be employed to perform the reverse operation simply by changing the terminal connections shown in the schematic.

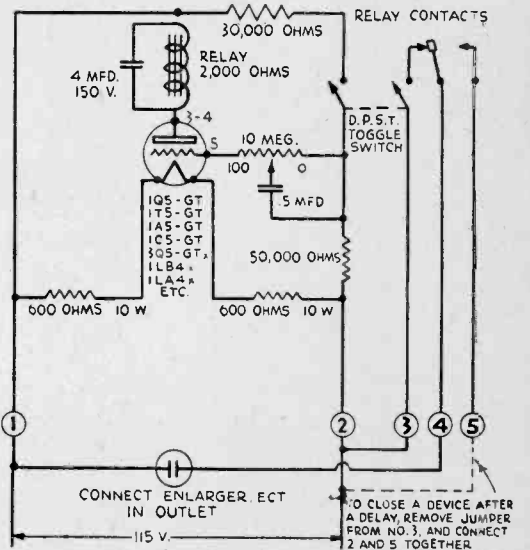

Now when the toggle switch is closed, the controlled circuit will remain open, and not close until a predetermined elapse of seconds. The circuit will then remain closed until the timer is reset. Tripping the toggle switch back to its "off" position automatically resets the timer.

The timer, using the 10 meg potentiometer and 0.5 mfd. paper condenser specified, will time from 0 to 35 seconds, approximately. However, the timing range can be increased by increasing the grid capacitance to 1 mfd. or more. A 20 meg potentiometer will still further extend the time delay to minutes.

There are no bugs prevalent in this circuit, but

if the timer is wired properly and does not function, look to the relay for the source of the trouble. Some relays may have the fixed contacts spaced too far from the moving arm, or the spring tension on the arm may be too stiff. The

solution is to carefully bend the arms with flat-nose pliers, or weaken the coil spring by removing it from the relay and stretching it slightly. The latter measure should be employed before bending the fixed contacts.

## Fun with a One-Tube ELECTRONIC ORGAN

**T**HIS novel electronic organ employs a simple tuned oscillator circuit, much like that employed in elaborate electronic instruments. However, where the real organ uses many individual oscillators as well as mechanical devices for its effects, the little organ described here limits its scope to a simple one-tube circuit. Yet with its simplicity and limitations, this organ produces musical effects ranging from tuba-to fife-like tones. In the middle ranges, it sounds much like any reed type organ. The organ keyboard consists of 20 chromatic notes. These may be played in a choice of four ranges from treble to bass. The tap-switch on the keyboard functions much like the "stops" on a conventional organ.

The heart of the instrument is the oscillator. A small metal chassis  $3\frac{3}{4}$  in. long,  $3\frac{1}{4}$  in. wide, and  $1\frac{1}{2}$  in. high is made to general design shown in illustrations. However, oscillator can be wired up on a wooden base, if desired. Our pictorial wiring plans show oscillator details so that assembly may be left to individual choice. The oscillator employs a type 117L/M7GT tube. This tube is really two tubes in one glass envelope: a power pentode and a half-wave rectifier. And since it has a 117 volt filament, no resistor or transformer is needed to lower "heater" voltage.



Completed electronic organ consists of: left, 20-key console with control providing 4 tone ranges; center, 5 in. PM speaker; and right, 1-tube oscillator.

It plays tunes with tone effects ranging from a reed organ to a bass tuba

By THOMAS A. BLANCHARD  
Electronics Engineer

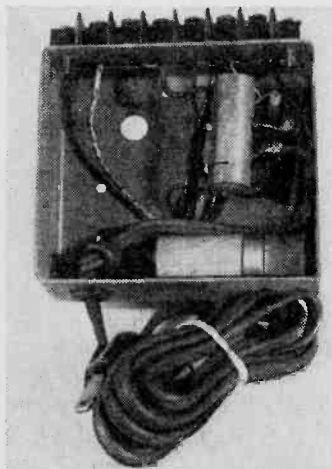

Bottom view of oscillator-amplifier which is heart of organ. Lower right, 20 mf. condenser; center, .05 mf. condenser, with tube socket below it. Tube and input transformer are located on top of chassis.

The 117L/M7GT contributes much to the circuit's simplicity.

A 6-post terminal strip on front of chassis provides means for connecting PM speaker, keyboard, and range control. Since the oscillator is a complete assembly in itself, overall construction of organ is greatly simplified. After obtaining components given in materials list, wire according to picture plan.

With the oscillator completed, test it by connecting a .00035 mfd. fixed mica condenser across terminals #1 and 2. Then attach a 470,000 ohm,  $\frac{1}{2}$  watt resistor across terminals #3 and 4. Finally attach a PM speaker (through a matching PM output transformer) to terminals #5 and 6. Plug cord into power line and allow oscillator to warm up. After warming up, oscillator should produce a high whistle. If not, check wiring carefully. If everything is in order, reverse primary connections of 3:1 ratio audio input transformer. This will place primary and secondary polarity in proper relation and unit will then oscillate.

Now if the 470,000 ohm resistor is replaced

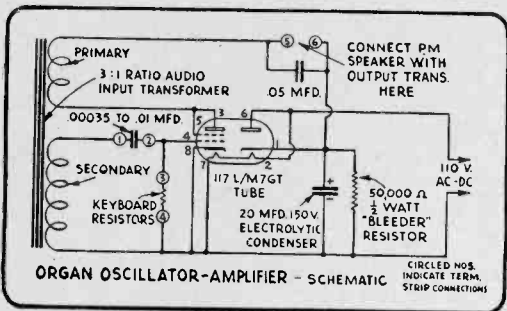
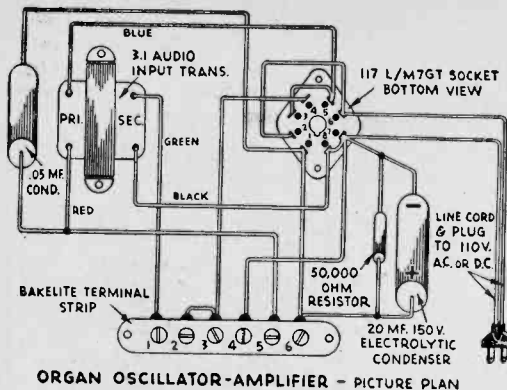

with a somewhat higher value, a different tone will be heard. Therefore, since each change in grid return resistance produces a different tone, a string of resistors, each with a "tuned" value, will reproduce all tones in the musical scale. The keyboard, therefore, is actually nothing but a series of switches—each black and white key closing the circuit along a series resistance network, and causing a different resistance to be placed between grid and ground of oscillator tube.

To save time, you can use well-seasoned white pine Xylophone keyboard (see drawings) in place of piano-type keyboard. Use only dry material unless you want organ to be out of tune or worse! Arrange 20 nickled or brass thumbtacks in the manner shown. Under each tack secure resistor leads. It is very important that all connections are solid! Inspect tacks to be sure they are not tarnish-proofed with clear lacquer. If so, soak them in acetone to remove this film. Be certain that keyboard resistors are exactly the values given in Table A, and that no open or poor connections exist anywhere between R1 and R20.

With Xylophone keyboard finished, solder length of wire to free end of R20. Connect this lead to terminal #3 on oscillator. Run another length of flexible insulated wire from terminal #4 to a radio test probe. With the .00035 mfd. condenser still across terminals #1 and 2, you are ready to go. Touch each tack head with the probe tip and you get an electronically-produced note corresponding to those given on the keyboard diagram. Now shut off oscillator and

change .00035 mfd. condenser to a larger value: .0006, .001 or .01 mfd. The .01 mfd. will produce very low tones; .0006 and .001 mid-ranges.

Now with a working knowledge of the gadget, you can build up a regular type keyboard, if you wish, entirely from scratch, or get a head-start by purchasing a 20-note toy piano for about \$3.00. In the latter case, remove bells or chimes and revise key actions into individual switches in the following manner. There is usually enough room inside the average toy piano to include oscillator and a small PM speaker, making the organ completely self contained. You'll find that key actions in most toy pianos, as well as real instruments, work on knife-edge pivot system (see "exploded" plan of keyboard). Base of keyboard consists of two pieces of well-seasoned 1/4 in. plywood.

Each of these pieces measure 12 in. long by 4 3/4 in. wide. Take one panel and rip-saw into two pieces making cut 2 3/4 in. from the edge to give you one panel 2 3/4 x 12 in. and another 2 x 12 in. With brads and glue, attach 2 3/4 x 12 in. panel to 12 x 4 3/4 in. sub-base. The knife-edge pivot strip is placed against edge of 2 3/4 in. panel, and sandwiched-in by the remaining strip of 12 x 2 in. plywood which is also glued and nailed to sub-base.

The knife-edge strip is a 12 in. length of 3/8 in. steel band such as is used to secure shipping containers. If you can't secure one, use a 12 in. hacksaw blade or have a tinsmith cut a strip of 20 gage sheet metal to 12 x 3/8 in. Next cut out

TABLE A—KEYBOARD RESISTORS

(All resistors 1/2 watt size and 5% or 10% accuracy. A silver band on resistor is 10% grade. Gold band, 5% grade.)

R1 and R2 . . . . .	68,000 ohms	R11 . . . . .	39,000 ohms
R3, R4, R5 . . . . .	56,000 ohms	R12, R13, R14 . . . . .	33,000 ohms
R6 . . . . .	68,000 ohms	R15, R16, R17 . . . . .	27,000 ohms
R7 . . . . .	47,000 ohms	R18, R19 . . . . .	22,000 ohms
R8, R9, R10 &		R20 . . . . .	470,000 ohms

These resistors are STANDARD RMA values and not "freak" components.

"XYLOPHONE" TYPE KEYBOARD FOR ELECTRONIC ORGAN

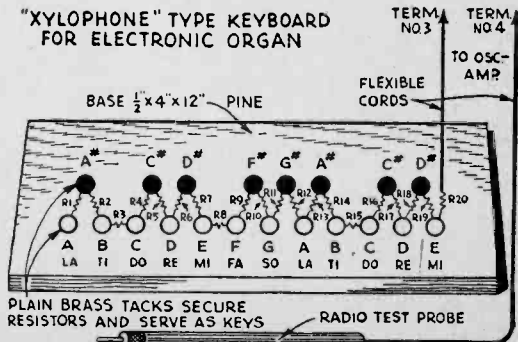

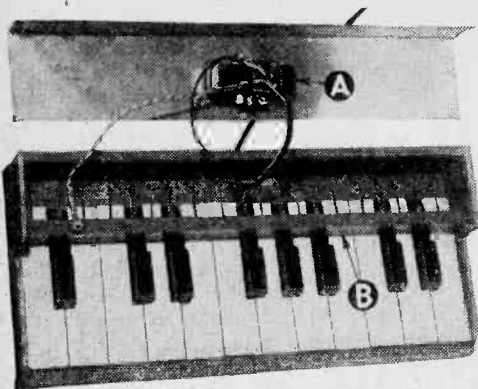

Console with aluminum cover removed. Note condensers and tone switch (A); position of contact bar (B). Keys slip under safety pin springs. Depressing key causes pin to raise and contact bar.

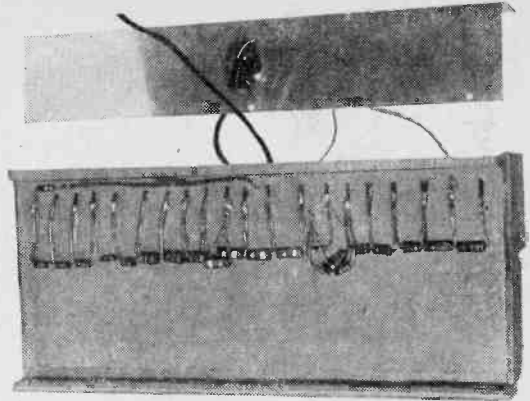

Bottom of keyboard showing resistors R1 to R20 soldered to projecting ends of safety-pin springs.

keys to dimensions on a jig saw. Use as narrow a saw blade as possible to slot each key on the underside to a depth of  $\frac{1}{16}$  in. Now arrange keys on base according to positions shown in photos. You'll find the individually-notched keys will ride on the steel edge in teeter-board fashion.

With all keys in place, draw a line across rear of base  $\frac{1}{8}$  in. in from edge. At center of each key position, make a centermark on parallel guide line. Do this manually as plotting off fixed spaces will possibly result in key-springs falling in the wrong position. Obtain two cards of #2 safety pins (20 pins) and with diagonal wire-cutting pliers, clip off clasp from each. Now, at each of the 20 marks along previously plotted parallel line, drill a hole (slightly smaller than

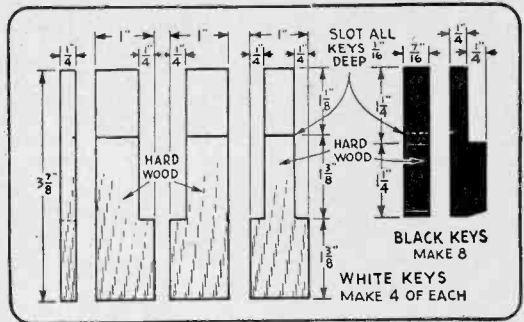

spring so that it falls in center of respective key. Now turn keyboard over and wire in the 20 resistors as shown. Projecting portions of springs serve as soldering lugs.

Finish the console with front, side and rear panels tacked and glued as shown. Now cut a strip of wood 12 in. long,  $\frac{3}{4}$  in. high, and  $\frac{3}{8}$  in. thick for the contact bar. To the  $\frac{3}{8}$  in. side fasten a strip of brass, aluminum, or tinplate with several brads. At a point where it won't interfere with the key action, solder length of insulated wire, or mount a soldering lug as shown. Set this bar, metal-faced side down, into the console. Position it as close to springs as possible, but

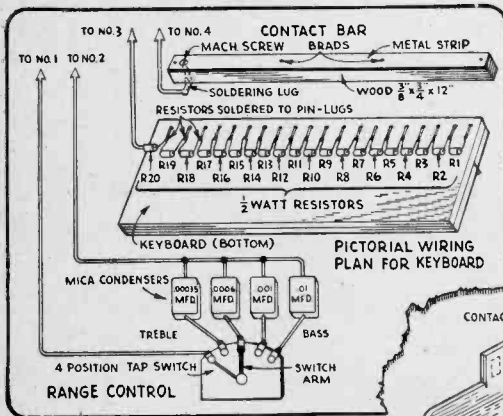

safety pin) through keyboard base. Now push a spring through each hole. Bend projecting portion of pin on underside of base down (see cross-section view in plans). With all safety pin springs in place, raise each one up and slide proper key in place. When key is depressed, it will now spring back. Align and adjust each

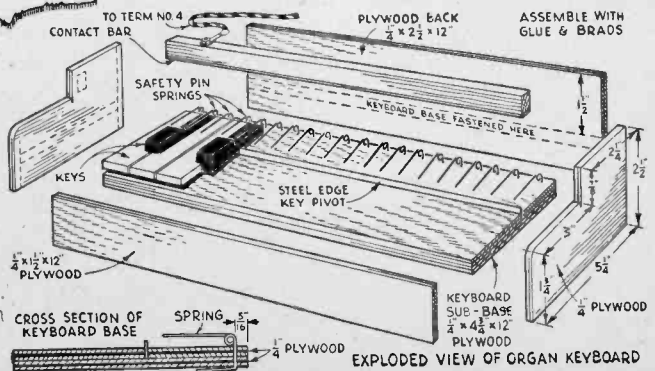





Keyboard base ready for keys. Lift spring and slide key under so slot (B) pivots on steel strip shown at (A).

without actually touching them. Now fasten bar securely at each end of console with small wood screws. As each key is pressed, lever action causes individual spring to raise and contact the bar. This closes circuit and sounds that particular note. Springs may be individually adjusted by careful bending with flatnose pliers.

A metal cover consisting of a piece of light aluminum conceals the actions and provides a mounting for the 4-position tap switch and mica condensers which make up the range control. By notching end panels of console as shown, cover front slips into these slots and requires only three small screws across rear top edge to secure it.

Since this organ employs but a single oscillator, it is necessary to strike only one key at a time. The natural limitations of the circuit do not permit the playing of chords.

However, a little practice with the device will result in rapid fingering that is not possible with any instrument other than those of electronic nature. The novel effects greatly offset its shortcomings.

## Surplus Control Box Becomes Multimeter Case

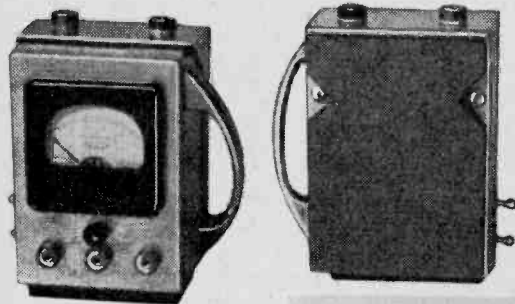

**M**ANY radio constructors have purchased surplus jack and control boxes in order to obtain the parts in this equipment. It will be found that these boxes make excellent cases for multimeters and other similar

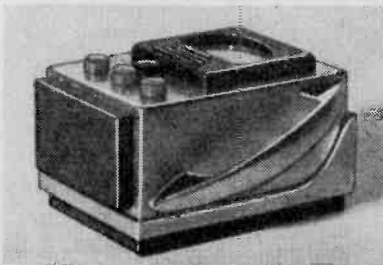

By HENRY ZAVE

equipment, since they are generally made of strong die cast aluminum or magnesium alloys.

The multimeter illustrated uses a typical standard circuit with the usual multipliers and shunts. Pieces of thick felt are cemented to the back and one end so that the unit may be placed in the most readable position. Note that two triangular cuts in the felt on the back allow easy

removal of the screws which serve to hold the case cover on. At first glance the handle shown may seem unnecessary on so small an instrument, but it will be found to be a great convenience since it helps to prevent inadvertent damage to the instrument by providing a definite place to grip it.

Three views of control box case with multimeter installed.

## Cut That Interference

• Sparking contacts on door bells and buzzers cause raucous interference in nearby radio receivers. Much of this may be prevented if a



one or two mfd. condenser is bridged directly across the contacts of the bell or buzzer. Such condensers absorb most of the spark produced.

## Fuse in Rectifier-Transformer Circuit

• It is not an uncommon happening that in radio sets having the rectifier and transformer connected in a common circuit, the transformer burns out because of a short in the rectifier which causes the current to back up. This can be prevented by inserting a fuse between the rectifier and the transformer. If this is done and the rectifier shorts, the short will burn out the fuse and so break the circuit, thus saving the transformer from being burned out, too.

# Three-In-One Electronic Set

Part I. How to build a powerful all-electric midget radio! Subsequent parts will show how to convert it into a home broadcaster, as well as a practical electric eye

By THOMAS A. BLANCHARD

Electronics Engineer

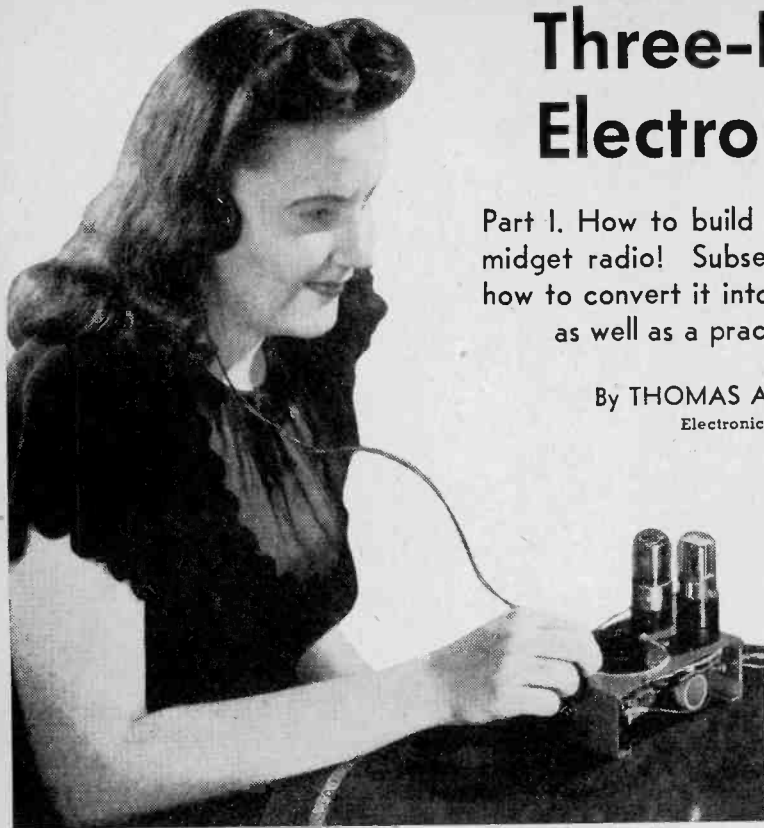

Judging by the lady's smile, reception must be very good.

**I**F YOU HAVE never attempted to construct your own radio, here is your chance to produce a genuinely powerful little set in just a few hours of interesting work. Although hardly a handful, this miniature all-electric set provided amazing results by operating a loudspeaker *without* a ground connection or outside antenna! For the record, the antenna was exactly 3 feet long, and received WJZ, WEAf, WABC, WOR, WLIB, and WHN (N.Y.C. stations) during daylight hours from a reception point in Connecticut.

Following the picture diagram, and the few suggestions on operation given later on, anyone can assemble this radio and obtain excellent re-

sults. It will be noted that the set was designed from a one-piece chassis to simplify wiring as well as forming of the metalwork. The chassis begins with a piece of aluminum or steel size  $3\frac{1}{2}$  inches wide by 10 inches long, and 16 gauge. After cutting holes for sockets, tuning condenser, phones, volume control,

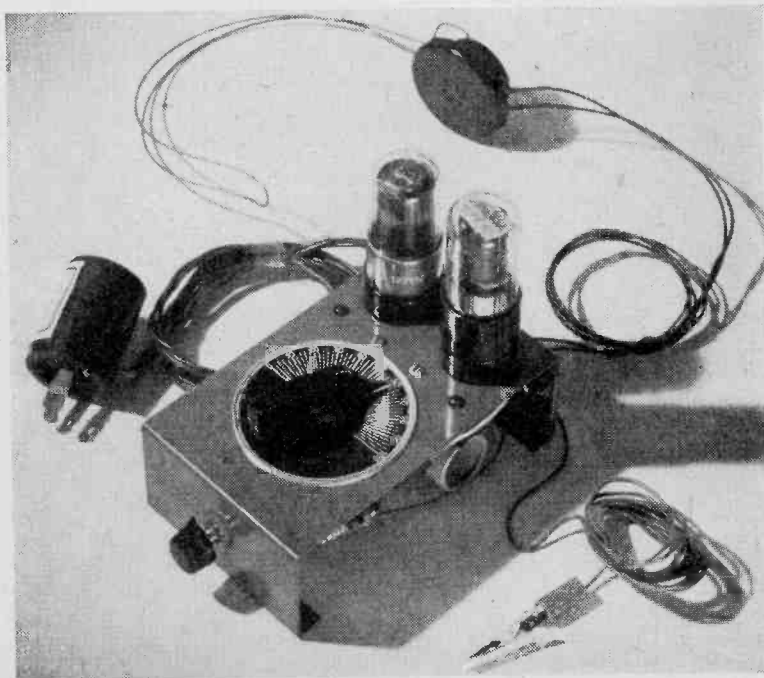

These are the components. 40-watt light bulb screwed into the socket shown at the left provides the necessary voltage drop.

and light cord, it is bent to the shape shown in the photographs.

Tuning condenser, potentiometer (volume control), and cord outlet are all  $\frac{3}{8}$  inch. Socket holes will be either  $1\frac{1}{8}$  inches or  $1\frac{1}{4}$  inches depending upon make of socket used. A 1 x 1 inch opening in the rear of chassis permits you to mount a bakelite strip. Phone or speaker connectors are attached to this strip.

The tubes chosen for the set are both readily available, and inexpensive. A type 6J5-GT, or 6C5-GT work equally well, as does their metal equal, the 6J5, or 6C5, if obtainable. A matched pair of any type can be used, or one of each—all fit the same socket

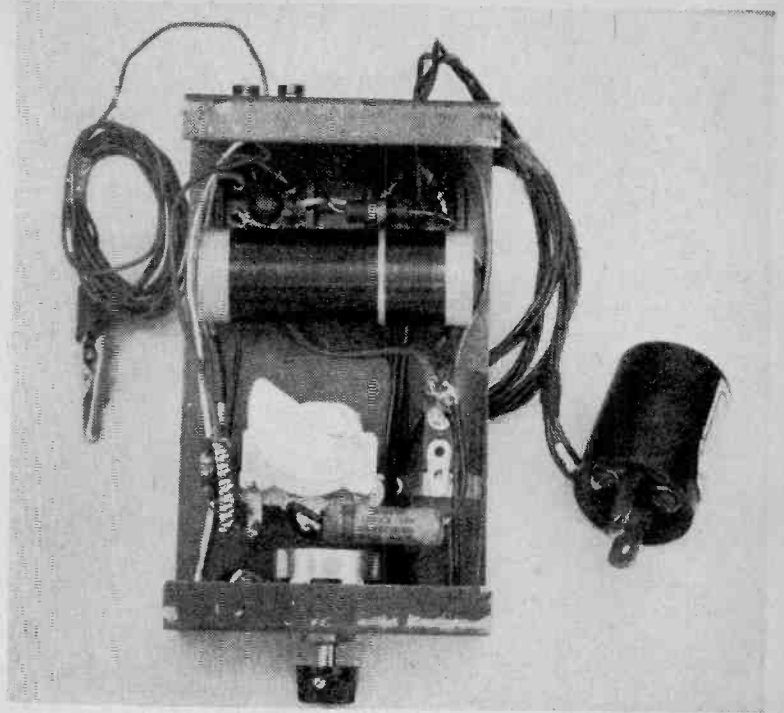

Details of connections on underside of chassis are shown in view above.

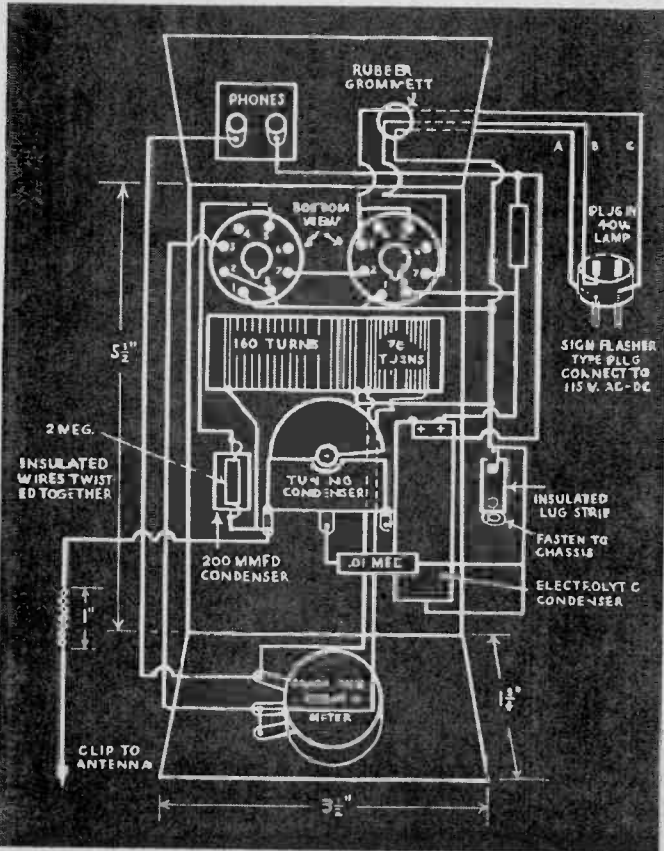

connections! The tube on the left (as viewed in picture diagram) is the detector, while the one at right functions as a rectifier to convert the A.C., from your outlet, to half-wave direct current to operate the radio.

The only component in the receiver that may require explanation is the coil. This was wound on a 3 inch length of craft tube having a 1 inch diameter, with No. 30 enameled magnet wire. The larger (grid) coil consists of about 160 turns, while the smaller (or plate) coil is 70 turns.

The coil can be wound by hand without much difficulty. Allow about 6 inches of wire for connecting to set at the start and finish of each winding. A useful winding kink is to push a straight pin into the tube, leaving just the head projecting. Wind the magnet wire around this and proceed to wind the larger coil by turning the tube away from you. At the completion of the winding, press another pin into the cardboard tube and twist the wire around to anchor it. Proceed with the winding in the same way. Since count-

ing turns is confusing, measure off the tube to allow  $1\frac{1}{8}$  inches for the large coil, and a little less than  $\frac{3}{4}$  inch for the plate coil.

A mounting hole is drilled at each end of the coil form, beforehand, so that the coil may be mounted on spacers using the two outside screws, which also support the tube sockets. This, however, is a minor detail and the constructor can mount the coil as he wishes. The coil windings can be made secure by painting with clear nail lacquer, or model airplane dope after coil is completed.

With the coil in place, measure the exact length of wire needed to reach from each coil lead to respective connecting point. Remove the enameled insulation from the end of the wire with fine sandpaper, and slide a length of insulating *spaghetti* over each of the four coil leads to protect them from damage.

The tuning condenser is a midget variable type having a capacity of 100 mmfd., and mounts in the  $\frac{3}{8}$  inch hole on the top of the chassis. The electrolytic condenser is mounted to the right of the tuning unit.

The exact capacity of the electrolytic condenser is not important. In the model shown, the capacity was 20-20 mfd., rated 150 volts. However, any dual combination from 4-4 to 50-50, with 125 to 150 volt rating will be satisfactory. If a dual unit is not available, use two single capacity units, and connect the negative ends together. If the dual unit consists of two unlike capacities, say 8-16, 4-8, 10-20 mfd., etc. the highest capacity is usually indicated with a red lead; the smaller in another primary color. The negative or *common* lead is always a black wire, or a bare wire. If the electrolytic condenser has two unlike capacities, connect the largest to the cathode (Terminal No. 8) of the rectifier, and the smaller to the phone terminal, with a 10,000 ohm resistor between them as shown in the two diagrams.

The volume control mounts in the  $\frac{3}{8}$  inch hole in the front apron of the chassis. A rubber grommet is inserted in the  $\frac{3}{8}$  inch hole in the rear apron and prevents damage to the 3-wire connecting cord. A strip of bakelite is mounted over the 1 x 1 inch opening on the rear apron. A pair of earphone jacks or Fahnstock clips are fastened to the bakelite for connecting earphone or speaker.

The quickest and most foolproof way to wire this set is to follow the picture diagram. Because of the set's design, all wiring is done inside the chassis, and the builder does not have to "chase" wires "upstairs and downstairs," through a dozen rubber grommets, and become confused as to whether that last wire was connected right.

With the larger parts mounted in place, and using a small soldering iron, rosin core solder and hook-up wire handy, attach one wire at a

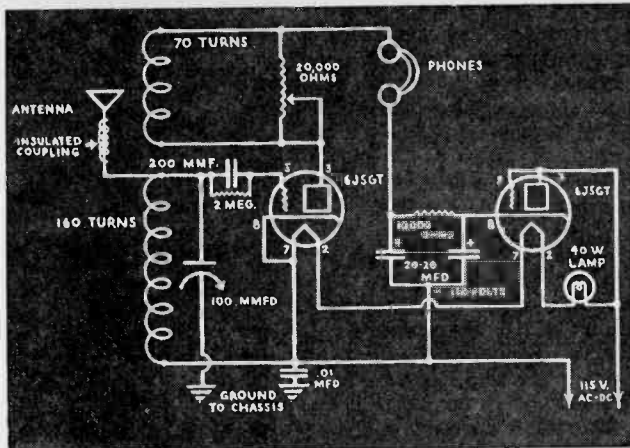

Standard circuit diagram for the midget set. Beginners can learn symbols by checking this diagram against preceding pictorial diagram.

time. As each lead is soldered in place, mark it off in colored pencil on the picture diagram. Thus if you don't finish the set in one evening, it won't confuse you later. There is no best place to start wiring. The constructor of the set will find it equally easy to start at any point and finish at any point.

Because transformers are almost impossible to obtain, and they only add cost to the set, this set was designed to work without such a unit. The plate (or B) supply is taken directly off the 115 volt A.C. or D.C. line. The filaments of the two tubes are rated at 6.3 volts. Naturally, to connect them directly to 115 volts would instantly destroy them. Therefore the filaments are wired in series with a suitable line drop resistor so that the tubes themselves never receive more than 6.3 volts.

There are several ways to obtain the necessary voltage drop. One method would call for the use of a ballast tube which gets very hot, and adds both to cost and increased size of the set. Another method available is a line cord with built-in resistance. However these cords also get hot and are not approved by the Underwriters. Aside from this, either of the two voltage dropping methods consume much more current than the radio actually requires. Since approximately 40 watts must be dissipated, we might as well put this loss to good use. Therefore instead of using a 300 ohm resistor, we employ a regular 40 watt (no more—no less) Mazda lamp. It's as simple as that.

Since the radio will be used, anyway, in the vicinity of a desk lamp, bed lamp, table lamp, etc., you need only insert the radio cord into the existing lamp outlet, and then plug the lamp into the top of the plug.

The plug, incidentally, is a bakelite flasher button used to make lights twinkle, and costs about a dime. Remove the flasher element from inside the bakelite plug, drill a hole in the side large enough for three wires to pass through, and connect these wires to the plug as shown in

diagram. If you can't get a suitable flasher button, connect your lamp and cord between wires B and C and use an ordinary plug, instead of the flasher button, to connect wires A and C.

### Operating Your Set

This set does not require a separate power switch. When the desk lamp is turned on, so is the radio. Allow about 30 seconds for the tubes to reach working temperature. Connect a single earphone, or headset, to the phone terminals. A short length of insulated wire, say 6 inches, is connected to the stator lug of the tuning condenser. Now take a longer length of the same wire and twist it to the shorter lead *without* removing insulation from *either*. On the opposite end of the longer lead, remove the insulation and attach a small clip. This may be secured to any metal object: finger stop on dial phone, bed spring, window screen, or outside antenna.

---



---

#### LIST OF MATERIALS

- 1—Dual section electrolytic condenser 4-4 to 50-50 mfd., 150 volts.
  - 1—Midget variable tuning condenser, 100 mmfd.
  - 1—200 mmfd. fixed condenser.
  - 1—.01 mfd. tubular paper condenser.
  - 1—20,000 ohm potentiometer.
  - 1—10,000 ohm  $\frac{1}{2}$  watt resistor.
  - 1—2 meg ohm  $\frac{1}{2}$  watt resistor.
  - 1— $\frac{3}{8}$ " rubber grommet.
  - 2—8-prong "octal" sockets.
  - 2—Fahnstock clips or phone tip jacks.
  - 1—Steel or aluminum chassis as per diagrams.
  - 1—12 ft. single conductor fixture wire.
  - 1—3 ft. plastic or cotton hook-up wire.
  - Miscellaneous—Four 6-32 machine screws and nuts, flasher plug, small piece bakelite, coil form, single terminal lug, and small spool of magnet wire for the coil.
- 
- 

In larger communities you won't have to connect this clip lead to anything to pick up local stations. If most of your local stations are at the lower end of the dial, very loose coupling between the set and antenna is desired. Therefore, use only a few twists on the insulated wires. However, if the stations are at the top of the dial, connect your antenna through a goodly number of twisted turns, or use a direct connection to the lug on the condenser.

This set has been designed to produce minimum regeneration. If more sensitivity is needed in remote locations, add a few more turns to the plate coil winding. To tune in stations, turn volume control to left, then rotate tuning knob slowly. Once a station has been located turn volume control to right until the reception is satisfactory. Distant stations will be recognized by a whistle. Tune to the peak of this signal, then rotate the volume knob to right until the whistle breaks off into regular reception.

Remember that this set is *not* like a weak crystal set which is neither selective, nor capable of working a speaker. The constructor can also use parts for other electronic experiments.

# ADSON

## RADIO & ELECTRONICS CO.

221 Fulton Street

Dept. SM

New York 7, N. Y.

An open letter  
to the readers of  
this publication

Our establishment has been a haven for *hobbyists* and *experimenters* for fifteen years. We have put many a *beginner* on the right track. We can do the same for you.

Come down to see us, or write us, about any kit of parts described in this publication. We are *certain* you will find our service and prices, *just right*.



# Three-In-One Electronic Set

**I**N THE preceding section of this article we described a very efficient all-electric midget radio which was the first project in a group of three designed to employ a common chassis, and simple conversion features, to change over to a different electronic device.

In this section, the simple details are given for converting the radio into a wireless broadcaster for transmission of either records or voice, through your radio set, from any part of the home. In the concluding part of this article the electronic set becomes a photo-electric eye!

Most of us, after listening to others broadcast for a few years, get the urge to show the rest of the world how entertaining we can be on the ether. So, we will proceed to convert the radio into a broadcaster.

In converting the radio into a broadcaster, note that few parts have been changed. In fact, the conversion is accomplished largely by the resoldering of a few connections, plus the addition of several condensers and resistors.

The right hand socket (bottom view of chassis) is unaltered. This was the rectifier of the radio, and remains as rectifier for the broadcaster. Naturally the original 6J5GT, or 6C5GT tube is still employed. The only circuit modification in the rectifier hook-up is to change the 10,000 ohm,  $\frac{1}{2}$  watt resistor to a 5,000 ohm value.

The left hand socket (bottom

Part 2. Converting the all-electric midget radio into a wireless broadcaster is easy

By THOMAS A. BLANCHARD  
Electronics Engineer



Broadcaster in use (above) and underneath view (left). This broadcaster was converted from the receiver described in detail in the preceding section of this article.

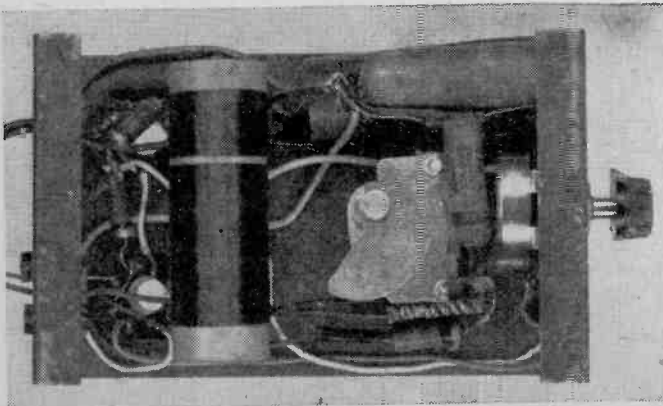

view again) originally provided for a 6J5GT or 6C5GT tube working as a detector. In the broadcaster, we replace this tube with a 6A8 (or 6A8GT, or 6A8G) which is a Pentagrid Converter. The leads to this tube socket remain the same on lugs 1, 2, 3, and 7. Originally we did not use lugs 4 and 6. These lugs are now connected together and wired

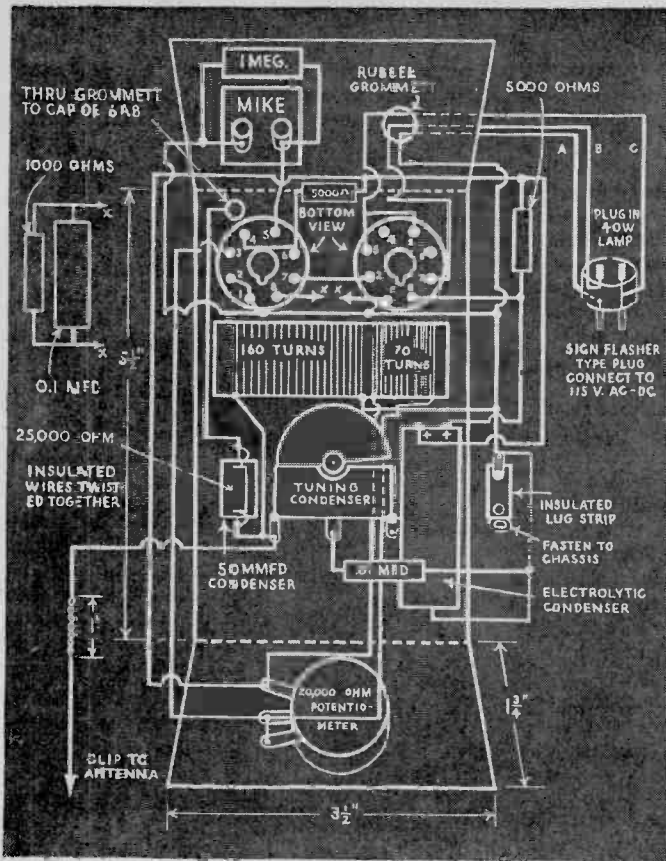

Pictorial diagram of converted broadcaster.

It does not appear in schematic drawing because it is incidental and, except for metal tubes where it acts as a ground for the envelope its use is simply for convenience.

The remaining change in circuit is the connection of the plate coil lead from the terminal strip to the point where the two 5,000 ohms resistors and 20 mfd. electrolytic condenser junction. Bring a wire from the vacated terminal to ground. Now connect a 1 megohm, 1/2 watt resistor across this and the adjacent terminal. This outlet, which was formerly for headphones is now the means for connecting either mike or phono pickup to the broadcaster.

Conversion from radio to broadcast set having been completed, the outfit is ready for trial.

Connect plug into 115 volt outlets, lamp or extension cord is then fitted with 40 watt bulb. Attach phono pick-up or mike to terminals and allow set 30 seconds to warm up. Also turn on radio receiver and with volume on full, set at a point between 1700 and 900 kc. where no regular radio broadcast reception is heard. In other words, set regular radio dial at a point where you do not get reception using a receiver set.

through a 5,000 ohm, 1/2 watt resistor to the rectifier plate (B) supply as shown.

Originally a 200 mmf. condenser, shunted by a 2 megohm, 1/2 watt resistor was connected to lug 5 of lefthand socket. This lug is freed and connected to one of the terminals marked, *mike*. Replace or add across the 200 mmf. condenser a 25,000 ohm, 1/2 watt resistor, and solder a flexible lead to the free end of the resistor-condenser. This lead comes up through the chassis to the cap of the 6A8 tube.

The remaining socket connection change is on lug 8. Originally this connected to the ground network. However still in the same network, we run this lead through a 0.1 mfd. condenser, shunted with a 1,000 ohm, 1/2 watt resistor. To avoid cramping, and confusion in reading the pictorial diagram, note this resistor and condenser are divorced from the pictorial diagram. Connect at points marked "x"; lug 8 of lefthand socket to lug 1 of righthand socket. Incidentally lug

Slowly turn dial on the broadcaster until a loud "swish" is heard through the radio. This is the carrier signal of your broadcaster. The volume control on broadcaster should be at extreme left. Once "swish" is located, adjust to peak signal, and turn volume control to right to increase

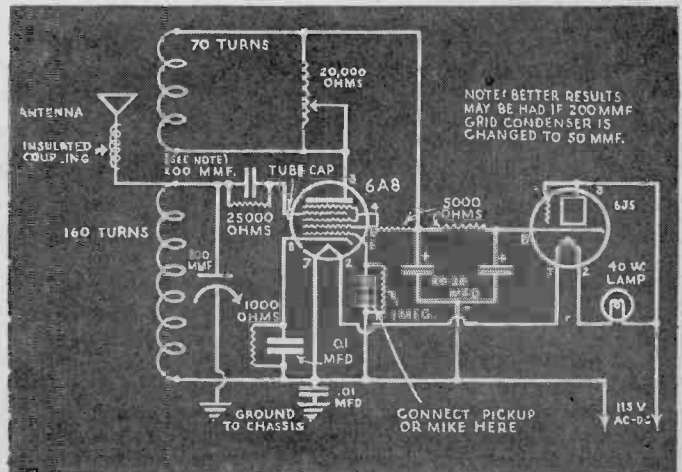

Schematic diagram of wireless broadcaster.

feedback for maximum volume. Do not turn too far as continued rotation to right will reduce and eventually cut off signal.

Using an inexpensive phono-pickup together with either an old spring-wound phonograph, or electric turntable, will result in brilliant recorded music coming from your home receiver, even when the little broadcaster is located at some remote point in the home. If you wish to broadcast voice, connect an old telephone transmitter to the "mike" terminals. If you cannot locate a suitable

transmitter, buy one of the "wonder" or "magic" buttons advertised in this and other publications and use as directed. Or buy a home broadcaster mike; any of these devices will transmit voice over your miniature broadcasting station.

**WARNING:**—The Federal Communications Commission allows 200 feet as maximum legal distance for the range of a broadcaster as just described. Under severe tests, we operated this device without the 3 ft. antenna shown in drawing; results were excellent. If you require more signal strength use a short lead, but remember if your neighbor hears your signal, you're **OUT OF BOUNDS!**

## Converting 3-in-1 Electronic Set Into a PHOTO ELECTRIC EYE

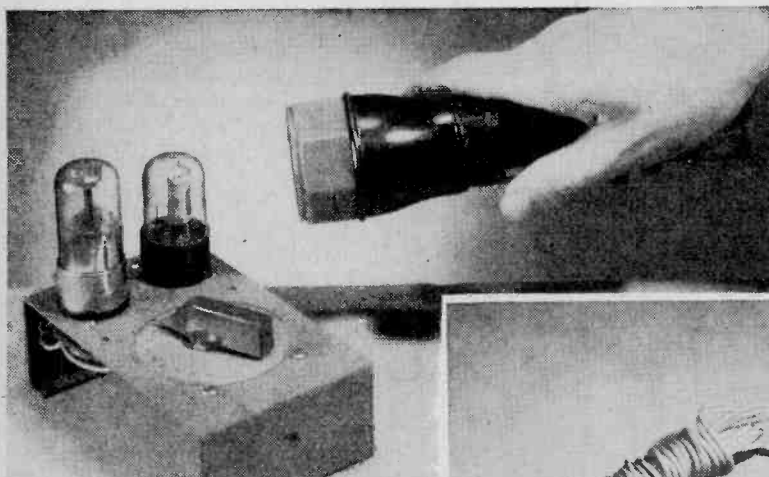

Flashlight beam focused on phototube at right can actuate the electronic control. Closeup of finished "eye" is shown at right.

### Part 3. Now let's turn it into a useful electronic control

**A** GLANCE at the pictorial diagram will reveal the *electric eye* is simpler than either radio or broadcaster. The basis of good results is largely in the relay. In the model described, we have used one of the original 6J5GT tubes. Having used a really sensitive type relay, the current delivered by this tube was ample to trip this particular relay. In order to operate a more sluggish type relay, the 6J5 tube socket has been wired so as to permit the use of a type 50L6GT Pentode. This interchangeability is possible because when using a 6J5GT tube, pin positions are the same as a 50L6GT except that the 50L6GT has an extra element, a screen grid which terminates on pin No. 4. As this pin is a blank on the 6J5GT, you connect pins No. 3 and No. 4 together and you're set for either tube.



The *electric eye* is wired according to the pictorial plan or schematic diagram. The tuning condenser and coil are removed from the chassis (if you built the previous devices). Tube sockets remain in position, but other parts should be removed and wired in according to the diagrams accompanying this article.

Remove the potentiometer (or volume control) from end of chassis, and mount it in the position

As in the earlier projects, a Mazda bulb is used to supply low voltage to the tube. For the *electric eye*, a 30 watt lamp is used when a 6J5GT is in the circuit, or a 25 watt bulb when the 50L6GT is chosen.

formerly occupied by the tuning condenser. The potentiometer becomes the "sensitivity" control of the *electric eye*.

The electrolytic condenser shown across the relay coil may be of the 4 microfarad value shown here. However, one section of the 20-20 microfarad condenser used in the other projects may be employed for the purpose.

There are no other special comments except for the sensitive relay. This relay should have a DC coil resistance of at least 2,000 ohms. It is mounted below the potentiometer as shown. The *phototube* and *relay* represent the first and last words in successful operation of this control. The phototube functions as a light-operated switch. Basically, when no light strikes it, no electrons travel across the anode and cathode—its two simple elements. Light upon this cell allows a minute current to flow which is sufficient to start a much large current flow in the amplifier tube (6J5GT, or 50L6GT). This current is then conveyed to the sensitive relay. The relay is the thing that really does the work such as causing bells to ring, lights to flash, etc., when the light beam is established or broken, as the case may be, in whatever control you rig up.

A look at the diagrams will show that the relay has 3 contacts. The two on the outside are fixed (rigid) while the center contact is part of the relay armature and moves from one stationary contact to the other when light strikes the phototube. These contacts are in true sense, a single pole-double throw switch. You always use the center contact, but you can choose either

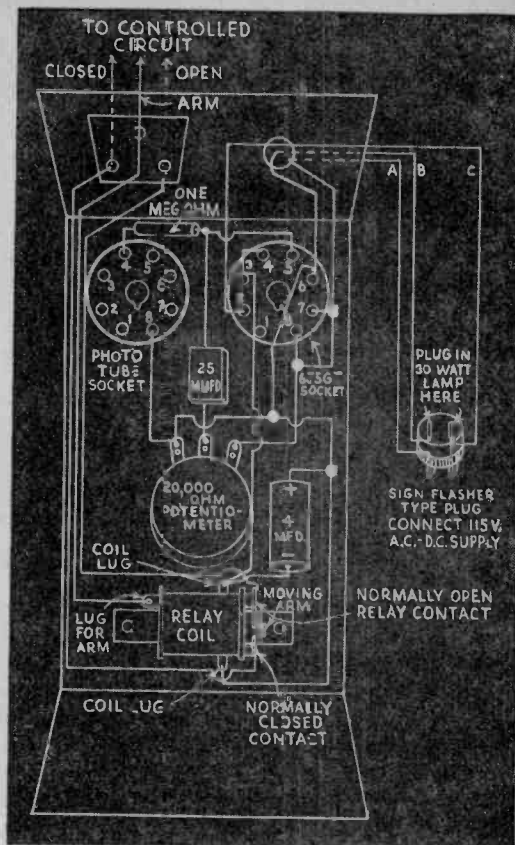

Pictorial wiring diagram.

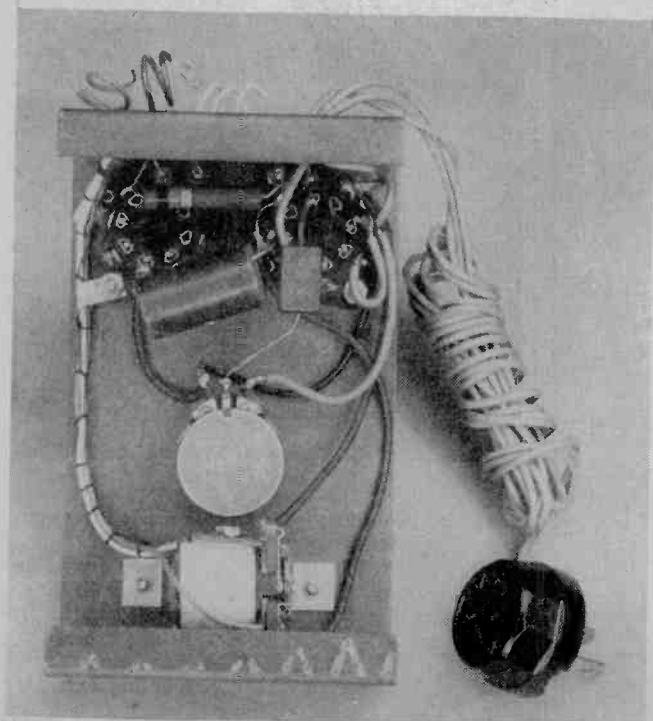

one of the stationary contacts depending upon what is to happen when the light beam is broken, or the beam is established.

For example, if the control served to open a garage door when headlights are directed toward the phototube, you would wire to *center contact* (arm) and *normally open contact*. However, if a constant beam was directed at photocontrol, and bell is to ring should object pass through, you would then use *center contact* and *normally closed contact* positions.

Having wired the control, insert the phototube in the righthand tube socket. This is the socket having only two wires connected to it. The lefthand socket is fitted with one of the tubes previously mentioned. Plug cord into outlet, then insert a 30 watt lamp into top of cap as dropping resistor for the tube filament. This bulb will provide enough light to operate the control. The constructor might even make a box with a lens and focusing tube so as







when terminals are bent they will almost reach correct terminals on tube sockets. Colors shown on schematic diagram are standard RMA color codes which identify 4 terminals of the I.F. transformers.

You can use any type standard loop antenna but loop should be small enough to fit into  $5\frac{7}{8}$

$x6\frac{3}{4}$  in. cover of cigar box which has inside dimensions of  $5\frac{7}{8}x6\frac{3}{4}$  in. You may obtain a new loop from a radio supply house or use the loop from a discarded radio receiver. One of the miniature loops now on the market may be used if desired. However, due to their extremely small size they do not have as much

signal pickup which will reduce the sensitivity of the completed receiver. The loop is mounted by cementing it to the inside of the box lid. Connections to loop may be made to tubular rivets mounted in the paper frame of the loop before cementing it in place.

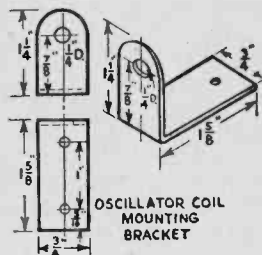
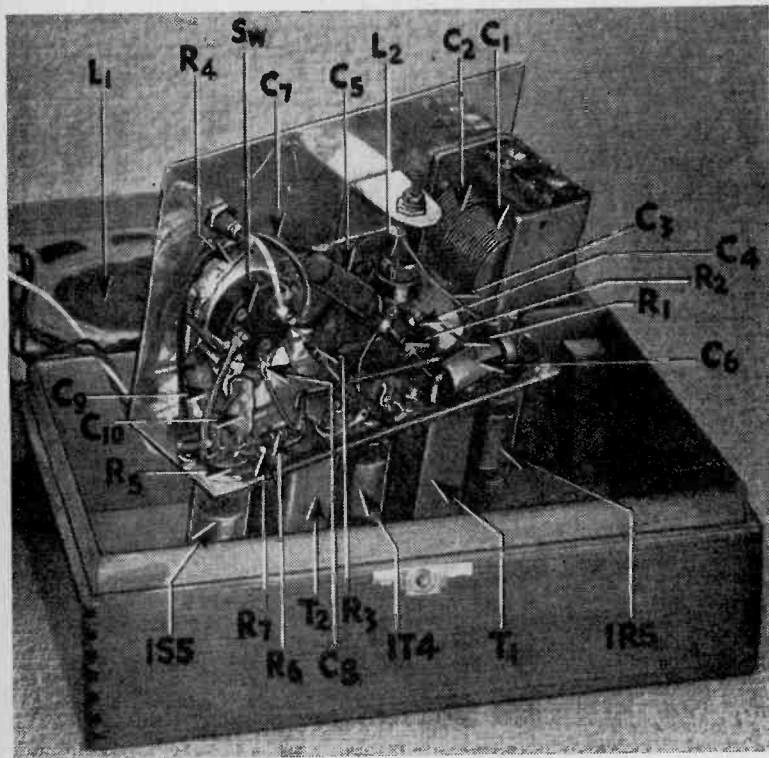

At left, underneath view of receiver, showing wiring of components. Identify parts by referring to schematic diagram. Note wooden block in right hand corner on which receiver chassis rests. A similar block is cemented in front right hand corner.

#### MATERIALS LIST—PORTABLE SUPERHET

- $C_1$ - $C_2$  2 gang cut plate variable condenser with trimmers (Allied Radio 61-008)  
 $C_3$ —.00005 mfd. mica condenser  
 $C_4$ - $C_5$ —.02 mfd. 400 volt condenser  
 $C_6$ —.1 mfd. 200 volt miniature condenser  
 $C_7$ —.0001 mfd. mica condenser  
 $C_8$ —.005 mfd. 200 volt miniature condenser  
 $C_9$ —.03 mfd. 150 volt miniature condenser  
 $C_{10}$ —.01 mfd. 200 volt miniature condenser  
 $R_1$ —100,000 ohms  $\frac{1}{2}$  watt resistor  
 $R_2$ —10,000 ohms  $\frac{1}{2}$  watt resistor  
 $R_3$ —3.3 megohm  $\frac{1}{2}$  watt resistor  
 $R_4$ —1 megohm control (Mallory MR-53)  
 $R_5$ —10 megohm  $\frac{1}{2}$  watt resistor  
 $R_6$ —4.7 megohm  $\frac{1}{2}$  watt resistor  
 $R_7$ —1 megohm  $\frac{1}{2}$  watt resistor  
 $L_1$ —Loop Antenna  
 $L_2$ —Meissner 14-1040 Universal Oscillator Coil  
 $T_1$ - $T_2$ —Stanwyck Midget I.F. Transformers  
 $Sw$ .—DPST Switch mounted on  $R_1$  (Mallory M27)  
 Misc.—3 amphenol type 147-500 miniature 7 prong sockets  
 2 phone tip jacks; hardware; wire; solder  
 1 IR5 tube; 1 IT4 tube; 1 IS5 tube

Now for the receiver wiring. Oscillator coil is a universal type with an adjustable iron core which may be adjusted to match any type of cut plate tuning condenser. Terminal numbers on oscillator coil in schematic diagram may be determined by chart furnished with oscillator coil (see diagram). Condenser listed in parts list is recommended because of its small physical size.

Wire the filament circuit first. Next connect blue and green leads of I.F. transformers to correct terminals on tube sockets. By carefully bending terminals you can make them almost touch one another so that only a short connecting wire need be used. If these wires are longer than about  $\frac{1}{4}$  in., either or both tube sockets and I.F. transformers have been mounted incorrectly.

All ground terminals are connected to soldering lugs on chassis; these, in turn, are wired together. Connecting grounds together in this manner keeps resistance in ground circuit at a minimum and assures maximum performance from the receiver. One phone tip jack is not insulated from chassis and the ground connections are made to this jack. Another solder lug is

mounted under one of the nuts holding oscillator coil bracket. A jumbo-type solder lug is slipped over mounting stud of oscillator coil before this coil is mounted in its bracket. One ground is made by soldering a wire on frame of tuning condenser. The round metal tube protruding from the bottom center of the tube sockets acts as a shield between the terminals and should also be grounded.

Make connections to B battery using snap-on connectors which may be obtained from any radio supply house. Solder the three A batteries together with a heavy copper wire which will hold them in place. Flexible leads from this heavy wire connect the batteries to the set.

The receiver switch and tuning knobs must be extremely thin to allow lid of box to close. The large tuning knob was made from a piece of 1/4 in. tempered Masonite. The excess shaft cut from

the control was mounted in an electric drill and the Masonite blank for the knob was fastened to it. Knob was then "turned down" using the point of a sharp knife, and then hollowed out in back to clear heads of the three binder-head, 3/32x1/4 in. machine screws mounting the tuning condenser. Knob for volume control is made from a 1 in. plastic knob which is also "turned down" to reduce the knob thickness.

After the set has been completely wired and loop and batteries connected, it is ready for adjustment. Turn the set on and, with core of oscillator screwed completely in, turn tuning condenser until you hear a station. Then adjust I.F. transformer trimmers for maximum volume. These factory set transformers require little adjustment. If a signal generator is available, align I.F. transformers at 455 kilocycles. Next rotate tuning condenser until it is approximately 10 to 15° from the fully closed position. Now adjust oscillator coil core until local station nearest to 550 kilocycles can be heard.

Next rotate tuning condenser until local station at extreme high end of the band can be heard. Rotate tuning condenser until station can just be heard and then adjust padder condensers on oscillator or cut-plate section until station is received at maximum volume. If there has been an increase in volume repeat the above step until station is received with maximum volume. If the above steps reduce the volume, rotate tuning

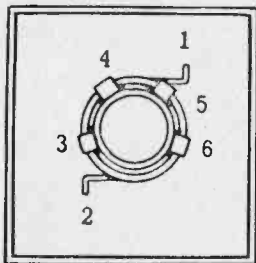
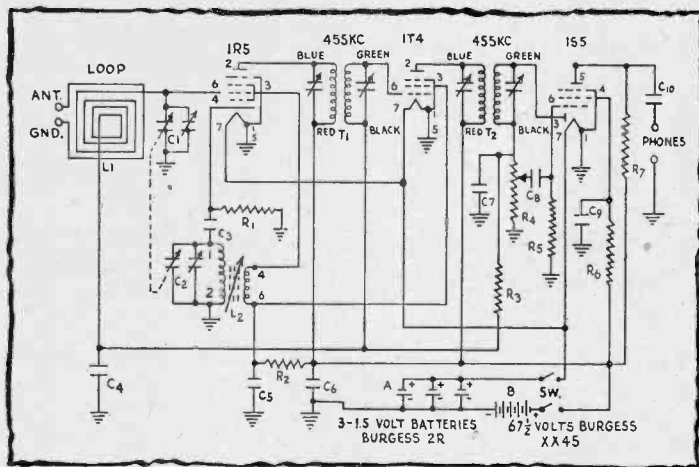

Universal oscillator installation data. Note space between lugs 3 and 6.

At right, completely wired chassis is shown in place in cigar box with batteries removed to show tube arrangement. Cigar box lid is propped open with a wire bent at each end and inserted into brad holes drilled in lid and box side.

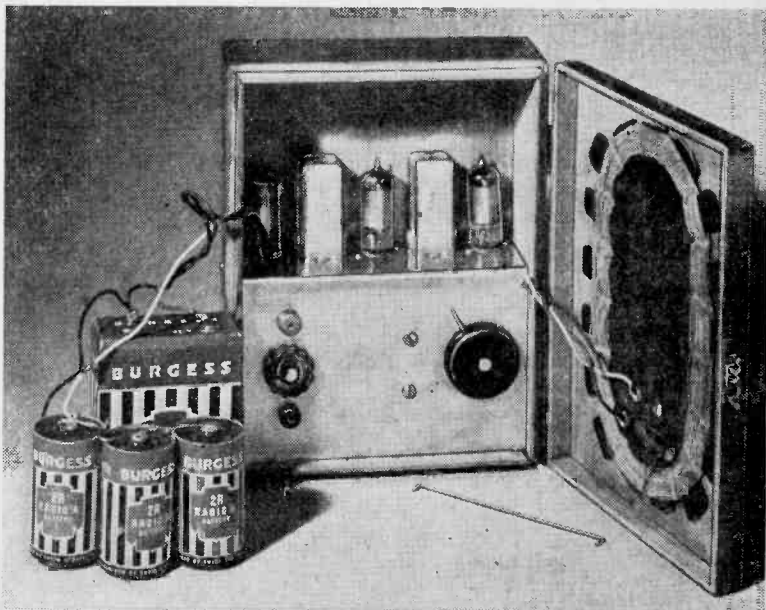

condenser in the opposite direction. Next adjust trimmers on large R. F. section of variable condenser for maximum volume. Then readjust core of oscillator coil as previously described and lock core in position. Then readjust oscillator and R. F. trimmers in the same manner as before.

Use headphones with a 2000 ohm or higher impedance. Loudest volume will be obtained from the phones with the highest impedance. If desired a paper dial may be mounted on the panel and the stations marked on the dial. However stations may be located without dial.

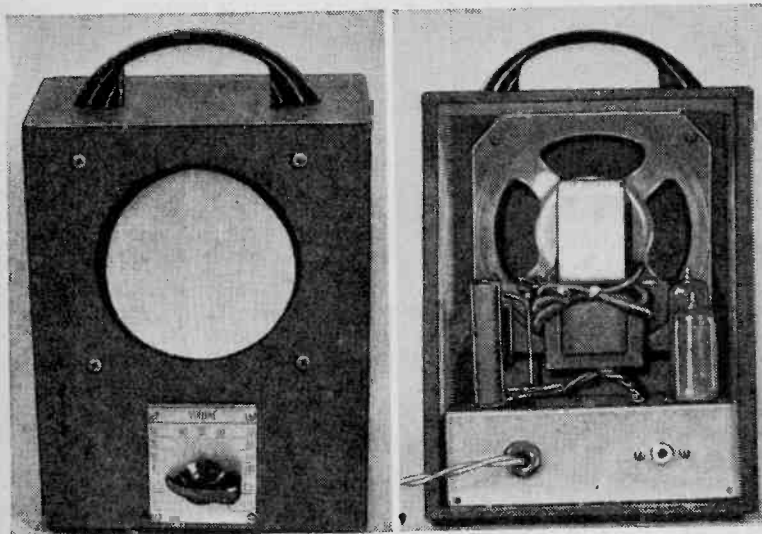

Left, red plastic fabric and molded handle give amplifier professional look. Cigar-box cabinet is only 5" wide and 7" high. Right, rear view with chassis and speaker in cigar-box housing. Speaker is installed with transformer down. Chassis may be removed without disturbing speaker and transformer.

## Miniature Multi-Purpose SOUND SYSTEM

This versatile, cigar box size amplifier plays records and "electrifies" guitars. Its terrific power will amaze you!

By THOMAS A. BLANCHARD  
Electronics Engineer

**H**ERE'S a really practical piece of electronic equipment every radio experimenter will want to own. It's a miniature public address outfit—an amplifier so small that it is housed, speaker and all, in a streamlined cigar box—and it has so many uses we can't name them all here. Plug in a phonograph crystal pickup and this unit can play records with more volume than your ears can stand. Or attach it with a contact pickup to a string instrument and you have an electric guitar, banjo, etc. For voice reproduction, a good,

At right, is a close-up of chassis. A. 150 ohm voltage drop resistor; B. mike or pickup input jack; C. leads to speaker transformer; D. Line cord.

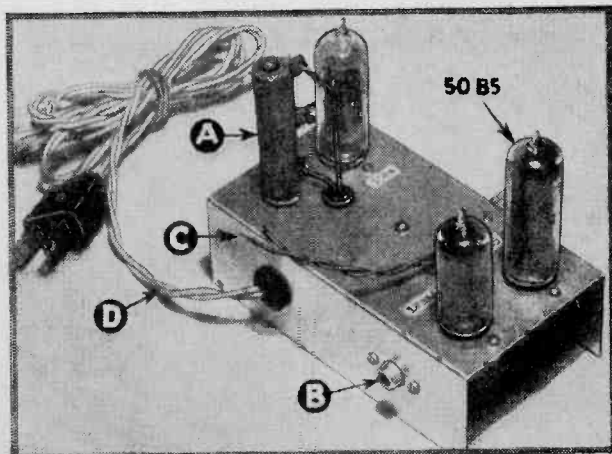

sensitive crystal mike may be used with this unit. For greater voice strength, use a quality carbon microphone and transformer fed by one or two flashlight cells. Among many other applications, this miniature amplifier may be used as a light beam broadcast receiver.

The extreme compactness of this amplifier is made possible through use of the new miniature ac-dc type tubes now on the market. No special or trick apparatus was used in constructing the model shown. The parts are 100% standard so that any person following the picture diagram can duplicate this outfit.

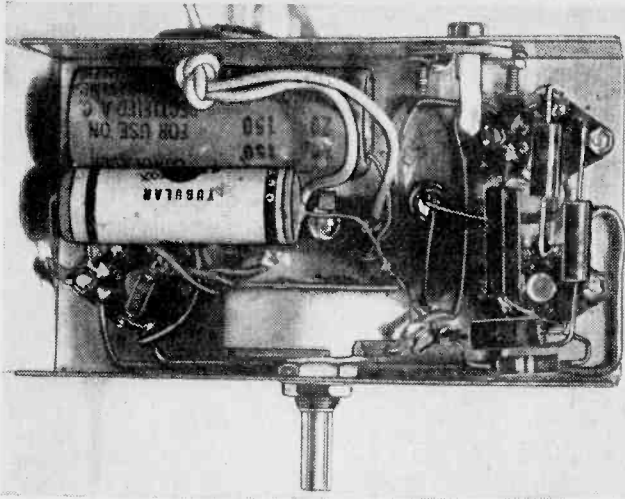

Bottom view of amplifier. Note that actual parts arrangement is identical to pictorial wiring plan.

cent to the tube sockets, add two 1/4 in. holes for the speaker leads and wires to the line drop resistor. The line resistor is a 10-watt, 150 ohm value mounted by a single machine screw in a vertical position next to the 35W4 rectifier tube. Resistor and tubes are arranged along the edge of chassis so that the center area is unobstructed to clear the speaker and transformer mounted under it.

A 2-post soldering lug strip is attached to the underside of the chassis so as to provide a convenient junction for the line cord, and the other component leads which are connected to this strip (see pictorial or schematic diagram). There is no

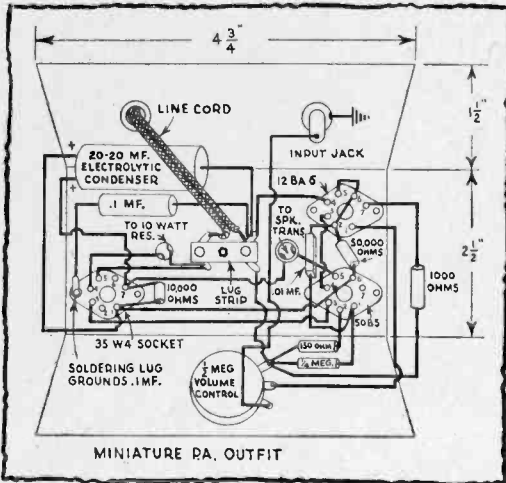

Before starting construction, obtain a suitable cigar box for the cabinet. A box required to fit our chassis dimensions must measure inside at least 3 1/4 in. deep, 4 3/8 in. wide, and 6 1/2 in. high. The box used may be larger, but not smaller. This type of box usually contains 50 cigars so you are sure to find one at your favorite newsstand.

The chassis is formed from a piece of aluminum or steel 4 3/4 in. wide by 5 1/2 in. long. Measure 1 1/2 in. on the 4 3/4 in. dimension and bend panel to form finished chassis so that it assumes the channel shape shown. A 3/8 in. hole is provided in the center of the front apron for the volume control. Two additional 3/8 in. holes are punched in the rear apron for "input jack" and power cord.

Three 5/8 in. holes are cut into the top of the chassis in the positions shown, for allowing the mounting of the miniature tube sockets. Adja-

Materials List—Sound System

CHASSIS:

Form from aluminum or steel blank size 4 3/4" x 5 1/2". Bend up both sides to form channel 4 3/4" wide, 1 1/2" high, and 2 1/2" deep.

CABINET:

Made from cigar box. See text.

RESISTORS:

- 500,000 ohm (1/2 meg.) Volume Control
- 250,000 ohm (1/4 meg.) 1/2 watt resistor
- 50,000 ohm 1/2 watt resistor
- 10,000 ohm 1/2 watt resistor
- 1,000 ohm 1/2 watt resistor
- 150 ohm 1/2 watt resistor
- 150 ohm 10 watt resistor (wire-wound)

CAPACITORS:

- 20-20 Mi., 150 V. Miniature Electrolytic
- .1 Mi. Tubular Condenser
- .02 Mi. Tubular Condenser (Optional; output noise filter)
- .01 Mi. Condenser

MISC. COMPONENTS:

- 3 7-Pin Miniature Sockets
- 1 Phono-Input Jack and Plug
- 1 4" PM Speaker with Output Transformer for 50L6 or 50B5 tube
- 1 Length fixture cord and plug
- 8 R.H. Machines screws and nuts size 3-48 x 3/8"
- 4 Rosette Head Screws and nuts size 6-32 x 3/8"
- 1 Volume Escutcheon Plate and Bar Knob
- Tubes: 50B5, 12BA6, 35W4

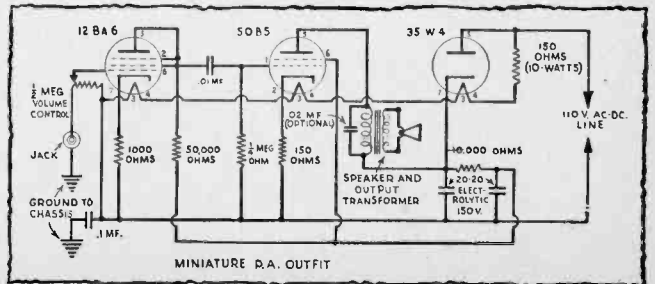



reason why the most inexperienced can't build this amplifier by closely following our picture plan, making certain that he has made connections to the proper tube socket lugs, and inserted parts using well soldered connections.

Note that all tube socket lugs are not used. Our readers from time to time think "something was left out." All tubes are designed with uniform pin systems for manufacturing convenience. Some tubes may use all pins provided; others may not. Therefore, make connections as shown.

When wiring to tube sockets, also bear this in mind: Tube element designations are read from the bottom of the socket—not the top! Miniature sockets are numbered 1 to 7 in consecutive order. The numbers in schematic diagrams appear out of order simply because it would be more confusing to draw elements of the tube in clockwise sequence, as they actually exist on the socket. Finally, note that in the miniature socket pin arrangement, there is *one wide space*. This is your start and finish. With wide space toward you, the first pin on the left is No. 1. Then reading clockwise around the socket you have No. 2

next, then No. 3, No. 4, etc.

If 500,000, 250,000, or 50,000 ohm resistors are not available, constructor may substitute 470,000, 270,000 and 47,000 ohm values.

The amplifier wiring is completely pictured in the pictorial plan as well as all components except for the speaker and output transformer attached to speaker frame. The two wires passing through the righthand center chassis hole connect to this transformer. The two wires passing through lefthand center chassis hole connect to the two lugs on the 10-watt, 150 ohm resistor. Otherwise, *all wiring is clearly visible!*

The striking appearance of the cigar box housing was achieved by covering it with brilliant plastic coated Cello-Fabric. This material was attached to the box with book paste. A chrome trimmed plastic handle and chrome volume control dial provided the finishing touches. A piece of silk, 4 x 4 in., cemented inside the box, made a neat speaker grill. The speaker opening was cut with a "fly-cutter" but you can work cigar box wood with a small keyhole or jig-saw.

## Alarm Clock TIME SWITCH

**M**ANY gimmicks and gadgets have been suggested for using alarm clocks as automatic time switches to turn electric lights, motors, etc., on or off at a predetermined time. This simple automatic time switch overcomes the many objections and complications usually experienced in converting an ordinary alarm clock into a timing instrument. Two standard electrical components, plus a suitable length of ordinary extension cord, are the only items

Wake up to music by plugging your set into this converted alarm clock

By THOMAS A. BLANCHARD

Electronics Engineer

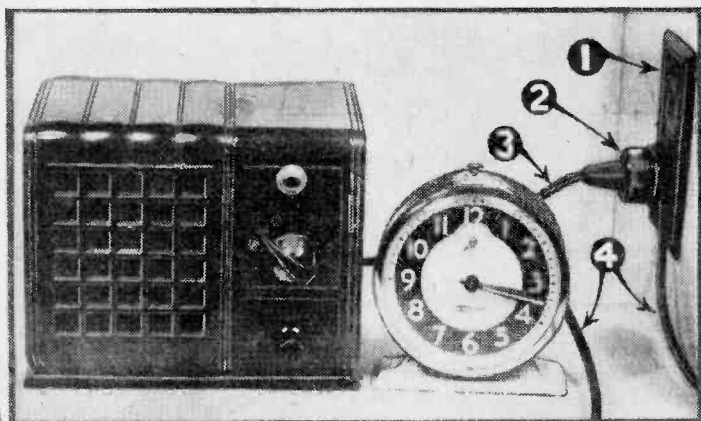

Radio is turned on at predetermined time by this attachment. (1) Wall outlet; (2) top plug; (3) radio cord; (4) clock switch cord.

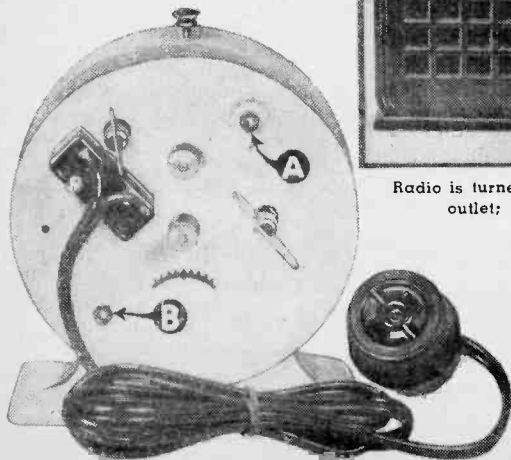

needed to change that annoying wake-up clang into sweet radio music at 6:00 A.M.

The self-contained timer consists of an inexpensive alarm clock available everywhere for about \$2.50 (practically any type alarm will do,

Rear view of clock showing Switchette depressed by alarm clock key. Exposed 110 volt connections on Switchette should be taped and covered with a wood or plastic box for insulation.

however). Movement is removed from case by first taking off winding keys, then removing two brass nuts marked A and B in photo. Winding keys have lefthand threads. Turn them to the right to unscrew. Pull up alarm plunger and clock is then separated from case. The heart of the time switch is the small Bakelite unit attached to back of clock. This small cube is a GE Switchette—a sensitive circuit actuator which will either open or close an electrical circuit when the switch button is depressed. Where the Switchette cannot be obtained, regular snap action switches may be modified and used in place of the Switchette.

The Switchette is attached to the mounting case in the approximate position shown. First the two mounting holes are drilled or punched (an ice pick will usually do the trick) in the clock case. Size of holes will depend on whether you use machine or wood screws (see instructions below). Now replace the two winding keys, and with the alarm in "run down" position, give the alarm key five turns. Now you are ready to mount the Switchette, using either one of the

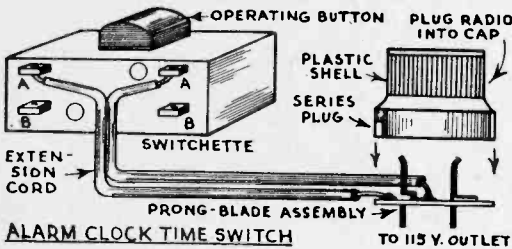

**ALARM CLOCK TIME SWITCH**

following two methods. Secure two 5/8 in. No. 2-52 machine screws and nuts, position the nuts behind the mounting holes with Scotch tape, and insert the machine screws in the holes, turning gently until each screw grabs the nut taped behind its mounting hole. Or if you prefer, you can make smaller pilot holes in the clock case and use ordinary No. 2 wood screws, which will be self-tapping and thus eliminate the need for opening the clock in order to mount the switch.

The Switchette is now ready for wiring to a length of extension cord. Some of these sensitive switches are designed to close the circuit when button is pressed. Others will open the circuit when button is down. A third type (shown here) provides two circuits; either of these may be selected, or both may be used together. Note that extension cord is connected to lugs A and A on switch. These lugs close the control circuit when button is depressed. Lugs B and B are used when you wish a circuit to remain closed for a given period and open when the alarm goes off.

Opposite end of extension cord connects to a combination outlet and plug, known as a Woodwin Series Tap, which is stocked by electrical supply houses. Solder the cord to positions shown in accompanying sketch. Replace Bake-

lite cap on plug base, and the alarm clock time switch is complete.

To use the timer, set the alarm for the desired time. Now pull up alarm plunger and turn key about 1/4 turn, or just enough to release any pressure on the Switchette button. At the predetermined setting, the alarm mechanism will release, causing key to unwind and close Switchette button. Series Tap is inserted into the electrical outlet. A radio or other appliance is plugged into blade slots provided in the top of the tap. Current from electrical outlet must pass up through cord and Switchette and return to complete a circuit to device plugged into top of Series Tap. To reset time switch turn alarm key just enough to release pressure on switch button. Always reset with alarm plunger pulled out. Hold the key and then depress the plunger in order to keep the circuit open.

**Shield Wire with Tape**

- Wire covered with regular braided metal shielding is sometimes hard to get for home and auto radio work. Ordinary insulated wire can be shielded quite readily with metal tape, however. One type of tape is made especially for auto radio shielding purposes, and has an adhesive coating for wrapping around wire. If an indoor aerial made of adhesive metal tape is available, it can be used in the same way. In an emergency, the metal foil in a paper condenser can be cut into 1/4- or 1/2-inch tape width and wound around wire to be shielded, using a drop of loudspeaker cone cement or household glue occasionally to anchor the foil. Be sure to ground one or preferably both ends of the tape to the chassis with a bolt or clamp after applying the necessary shielding around the wire.

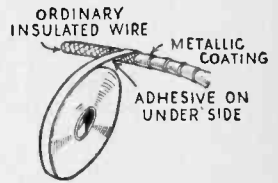

**It's Video for Television**

- Television is called video transmission to distinguish it from the transmission of sound which is called audio transmission.

**Polystyrene Feeder Spreaders**

- Radio amateurs who like to build everything themselves, can easily and cheaply make all their feeder spreaders. Use either 3/8 or 1/2 in. dia. round polystyrene rod. Standard sizes for feeder spreaders are 2, 4, 5, and 6 in. spacings between wires. Holes

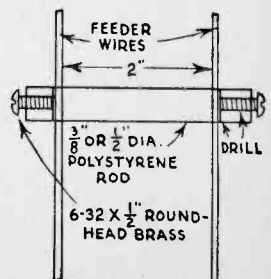

for wires should be slightly larger than the diameter of feeder wires used; space holes  $\frac{1}{2}$  in. from ends of rods. It isn't necessary to tap holes for 6-32 screws; simply use a drill slightly smaller in diameter than screws and twist screws into

the holes; screws will thread themselves in securely. Ends of rods can be beveled on the edges with a file to improve the appearance. Sketch shows a 2 in. feeder spreader installed on the lines.—ARTHUR TRAUFFER.

## LISTEN-EAR—A Real Radio Aid

**H**AVE you ever wanted to listen to the radio during late evening hours, or possibly to pick up distant or foreign stations which could be heard only faintly through the speaker? The *Listen-Ear* is a useful earphone attachment for any set. In particular it is a boon for those who are hard of hearing. Once attached to your receiver, you can listen in with earphones while the speaker serves others. A flip of the toggle switch and the *Listen-Ear* disconnects the speaker, and reception comes through earphones only. Moreover, whether both phones and speaker are working, or only phones, the adapter provides complete, independent volume control for earphone listening.

Follow the pictorial diagram to assemble the adapter and connect it to the set. The original

This earphone adapter is a fine project for the hard-of-hearing, and for late evening and DX listeners.

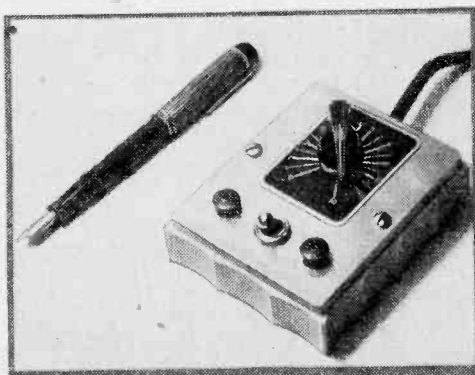

Left, close-up of the Listen-Ear. Phone connectors are at lower left and right, with speaker shutoff switch in center. Dial control provides "custom" phone volume. Below, Listen-Ear adapter in use with an operator's headset.

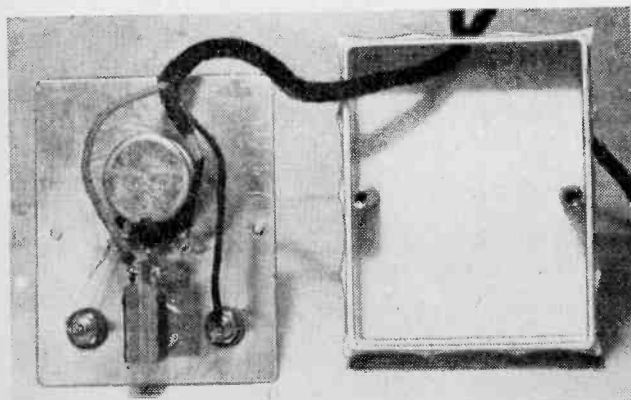
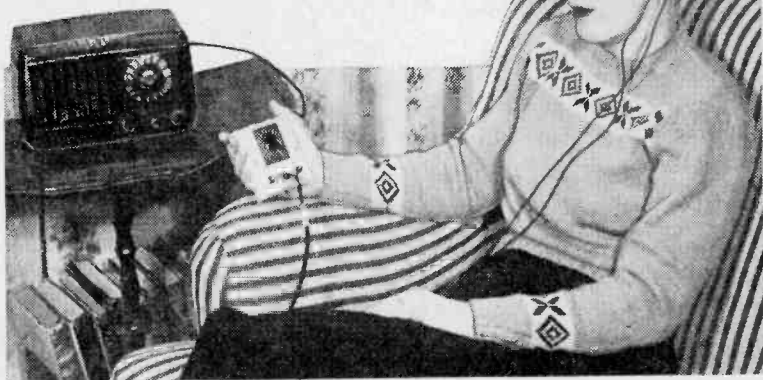

By **THOMAS A. BLANCHARD**  
Electronics Engineer

model, as pictured, consisted of a  $3 \times 3\frac{3}{4}$  in. panel on which was mounted a 1 megohm potentiometer (volume control), two phone tip jacks, and a toggle switch. These components are wired up as shown. The particular design or size of the control housing is very flexible. In this instance, the *Listen-Ear* was housed in a plastic cosmetic box.

Exposed view of earphone attachment. All parts mount on metal panel which attaches to plastic case via center studs.

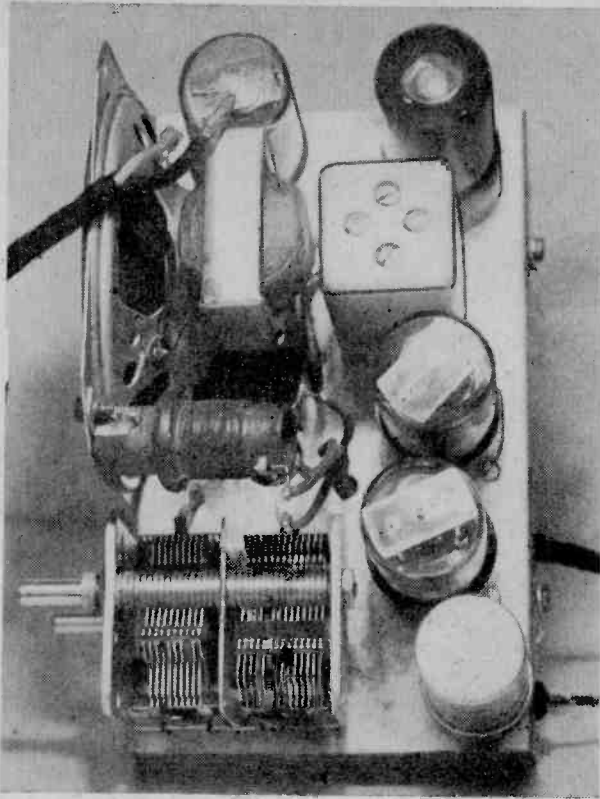

Typical small receiver showing a PM speaker and output transformer. Adapter cord is connected to set at this point.

former have been soldered to a pair of lugs on the speaker frame (A and B on drawing). Unsolder *one* transformer wire from speaker lug A. This now gives you a free lead, marked C in picture plan. The adapter is now ready for installation. Note exact positions of 3 wires and connect one to free transformer lead (C), attach second to lug B, and put third wire on now vacant A lug. You must attach wires from cable correctly; otherwise *Listen-Ear* will not work. Secure cable to some part of speaker frame with twine so that wire C is not subject to strain.

For best results, headphone or headset used with the *Listen-Ear* should have a resistance of 50 ohms or less. A regular hearing aid receiver is perfect for the adapter. In fact, a simple adapter may be made so that many regular hearing aid phones can do double duty. Our illustration shows an adapter for using the Zenith hearing aid receiver with the *Listen-Ear*. A strip of Bakelite was drilled at each end to accept a 6-32 screw. Two phone tips were then tapped with a 6-32 thread. The phone tip ferrule is just the right size for 6-32 tapping. A long flat soldering lug is placed under screws, parallel with Bakelite strip. These lugs are bent first to right angles, then twisted to right angles. Resulting blades fit hearing aid plug. Some plugs have 3 blade or pin slots. One is a dummy. Two *live* ones on Zenith plug are marked 5 and 6.

Two 1/4 in. threaded bushings attached to bottom of plastic box permitted firm attachment of the control panel.

A 3 ft. length of 3-wire cable serves as connecting link between adapter and radio. Cable may be made longer or shorter, but the suggested length is usually convenient for armchair use. If you can change a tube, you can attach the *Listen-Ear* to your set. If your radio is a console type, access to speaker is usually simple. With small table sets, you will need to remove chassis from case. Disconnect the set before you start. Now locate output transformer, which is usually mounted on speaker frame. Note that two wires from this trans-

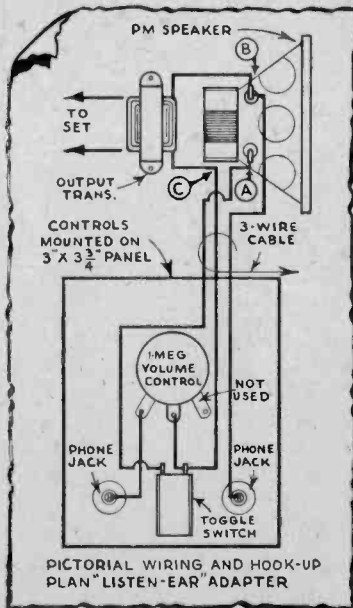

The hard-of-hearing may use regular aid receiver with this adapter. Note sample plug conversion shown in foreground.

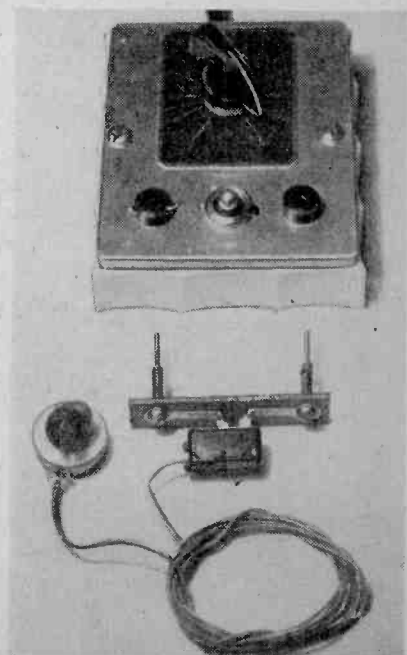

# TELE-TENNA

Build an adjustable television antenna  
with remote electric control

By THOMAS A. BLANCHARD

Electronics Engineer

UNLIKE ordinary AM radio reception, television and FM require a very special and exacting antenna installation for satisfactory pickup of the high-frequency signals. These signals have very short wavelengths and are highly directional. Therefore, to get the very best reception, the receiver's antenna must be *focused* for each station received. In areas where only one station exists at present, the antenna is aimed in the direction of the transmitter and locked. However, at this moment, FCC permits have been granted a score or more new television stations. When these new stations hit the air, you "telefans" across the country may not get full benefit from your set unless you climb a ladder each evening and set the antenna for the video show you especially want to see.

This electric-controlled antenna, however, will eliminate ladder climbing, and give you hair-line adjustment of the television antenna from the comfort of your living room. Precision adjustment can be made while watching the picture. You don't need a compass or an assistant on the roof to tune in sharply. The heart of this antenna system is a war surplus aircraft motor. This miniature geared down job costs just a few dollars, and even though it must be battery or rectifier-powered,



Television antenna is controlled from this compact meter case. Control functions are indicated on the panel.

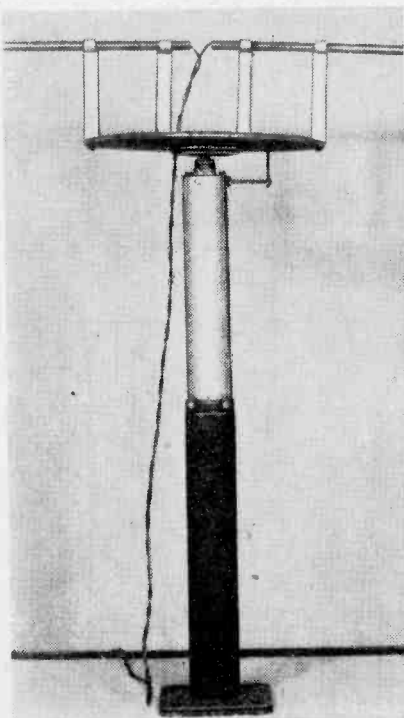

Motor-driven television antenna insures peak reception by permitting easy aiming. Here simple dipole antenna is shown attached to rotor disc.

the total investment is a fraction of any commercial motor-driven antenna. The control box hook-up which will be described here is for permanent magnet type motors only. If series type motor is used, reversing switch must be connected per instructions accompanying series type motors.

If you have a television or FM set, simply install the motor drive between the mast and antenna: dipole, double dipole, folded dipole, etc. Otherwise a standard antenna kit may be purchased and this motor drive incorporated before erection.

The miniature PM Magnet motor is unusually small, a shade under  $1\frac{3}{8}$  in. dia. and 3 in. long. It will make a snug fit inside a 6 in. length of  $1\frac{1}{2}$  in. dia. aluminum or steel tubing having a  $\frac{1}{16}$  in. wall thickness. Dealers in surplus aircraft materials

**CELLOPHANE FOR CONDENSERS.** Cellophane is claimed superior to paper as material for condensers in radios and for similar dielectric purposes, in U.S. patent 2,460,282, newly issued to Guy B. Gardner of Fairhaven, Mass. Paper, he says, is notoriously fibrous and grainy, and contains bits of carbon, minute fragments of metal and other conducting substances that are absent from the regenerated cellulose product. To remove the ionizable chemicals present in ordinary commercial cellophane and make it partially conducting, Mr. Gardner specifies washing them out, by successive immersions and scrubbing in alcohol and distilled water.



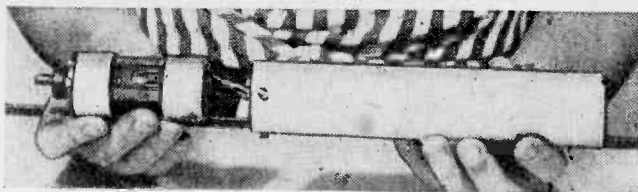

Miniature PM magnetic motor of aircraft surplus type makes a glove-fit inside 6 in. length of aluminum tube.

MATERIALS LIST—TELE-TENNA

- 1 24 volt DC, permanent magnetic surplus aircraft motor
- 1 6" length of thin wall aluminum or steel tube, 1 1/2" o.d.
- 1 8" disc of 1/4" Masonite
- 1 1 1/2" dia. pulley for 1/4" shaft
- 4 porcelain insulators threaded 8-32 (2 or 3" long, by 3/8" o.d.)
- \* 4 brass or aluminum clamps for 3/8" dia. tubing
- \* 1 mill standard length aluminum or brass tubing, 3/8" dia.
- 1 single pole, single throw toggle switch
- 1 double pole, double throw toggle switch
- 1 pilot light assembly with miniature screw socket  
or
- 1 500-0-500 Shurite milliammeter (see text)
- 1 Blank panel meter case or punched for 3" dia. meter (see text)
- 1 3 1/4 x 3 1/4 aluminum panel for meter case
- Misc. nuts, bolts, and lead-in wire per text

can supply tubing at just a few cents per foot. Electrical supply houses usually have steel thin wall conduit which is equally good for mounting the motor. About 1/2 in. from the end of the tube, drill four equi-distant holes around the circumference, and tap them for 6-32 machine screws. As the tubing is thin, we suggest you insert nuts on each screw, draw up the screws in the tapped holes, and then solder each nut to the tubing. With a small blow-torch and stick of Lenk aluminum solder, nuts can be bonded to tubing so as to provide sufficient thread surface for the 6-32 screws. There is little chance of stripping threads this way.

Now slip motor into tubing, allowing shaft end to project flush. Lock it in place with three 6-32x1/4 in. rh machine screws, and one 6-32 by 1 in. rh screw. All screws are brass. The longer screw serves as a rotation stop and signal light contact. Open end of tubing is attached eventually to antenna mast. If mast is a metal pipe, motor leads are brought down through it. If mast is wood, drill a 3/8 in. hole in the tubing, insert a rubber grommet, and pull the motor leads outside. Since the diameter and material of various makes of antenna masts will vary, no set rule can be given for attaching the motor mounting tube. How-

ever, the aluminum tube will usually slide over the mast. Several holes may be drilled in mast-end of tubing and tapped in the manner previously described. If the mast is of wood, insert wood screws instead of the machine type to secure motor mount to mast. If mast is not of sufficient diameter to make a snug fit inside tube, build up diameter with ordinary electrician's friction tape.

A circular platform is attached to shaft of motor drive for mounting the dipole antenna tubes, and to provide a protective "umbrella" for exposed end of motor which, incidentally, rotates on ball bearings. The platform is cut from 1/4 in. thick Masonite to a diameter of 8 in. This disc is attached to the motor shaft by means of a 1 1/2 in. flange. Since a suitable flange would have to be machined by the builder, the problem is solved by using a 1 1/2 in. dia. round or V-belt pulley with 1/4 in. shaft hole. The prominent mail order houses can supply you with these pulleys.

Drill three equi-distant holes in the center of the Masonite disc, along with three corresponding holes in the pulley. Drill the pulley holes so they may be tapped for 6-32 machine screws. Four holes to clear 8-32 screws are

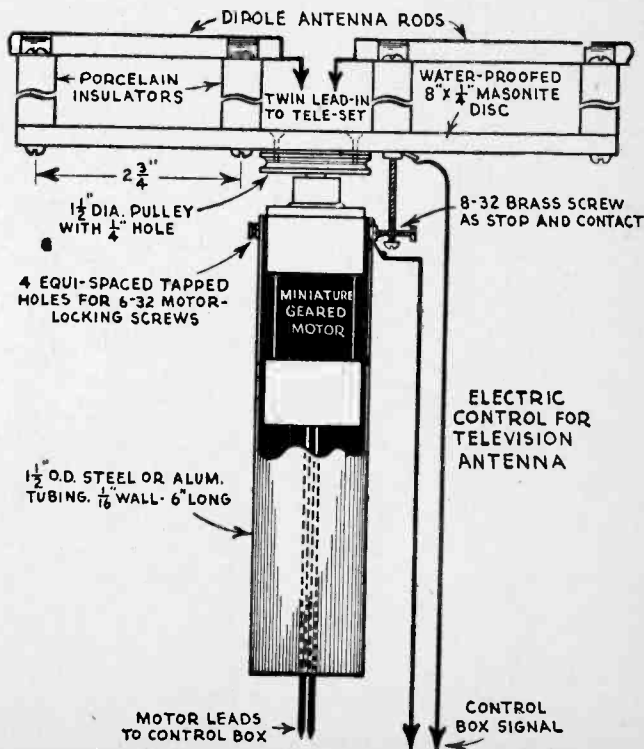

drilled across the diameter of the Masonite (see drawing) if a simple homemade dipole antenna is constructed. Secure the pulley to the disc with *fh* screws. Then paint disc with asphalt compound such as is used on roofs and for tree surgery. Cover disc edges carefully with asphalt so the Masonite will not take up moisture and warp. Dipole antenna tubes are supported on the Masonite disc with standard porcelain stand-off insulators available from all radio supply houses. These tubes are threaded for 8-32 screws on both ends. Mount the insulators with *rh* brass screws,  $\frac{5}{8}$  in. long, with the exception of the one insulator shown. Here a  $1\frac{1}{2}$  in. screw is used along with a nut and soldering lug. This screw is the other contact for the *reverse* signal light.

When the electric-powered antenna is eventually hooked up to the control box, this is how these contacts work. Upon making a complete rotation, the horizontal and vertical contact screws meet. This obstruction stalls the motor and at the same time, causes the pilot light on the control panel to flash on. When light flashes, simply flip *direction* switch and pilot light goes off; motor has reversed its direction and the contacts open. Since motor is in a stalled position for only a few moments, no harm will ever be done it. Once best antenna "focus" is obtained, simply snap opposite toggle switch marked *power* to its off position.

Since this project will be of particular interest to those already owning television sets, the large Masonite disc provides ample room for mounting various types of existing antenna. And for those contemplating a television set, the purchase of a factory-made antenna is advised. Attempting to cut and bend dipole tubing correct length and shape is a tough job. However, for the experimenter, a simple dipole as shown mounted on the motor drive consists of two lengths of  $\frac{3}{8}$  in. diameter aluminum or brass tubing cut according to formula A.

#### FORMULA A—DIPOLE LENGTH DATA

$$\text{Individual Tubing Length} = \frac{2700}{\text{MC Freq. at Tele-station}}$$

figured in inches

Example: If frequency was 46 MC, the answer is 60 in. for each dipole rod. Get up-to-date MC data in your locality in "White's Radio Log" sold on newsstands.

The twin lead-in is usually of 300 ohm impedance and is sold by all radio supply houses. However, the antenna input impedances do vary for various TV sets, and for proper results follow the specifications given by the set manufacturer. The neat-looking control box pictured is an ordinary 3 in. electrical meter case which all radio parts firms have in stock. The box is available with both a blank panel or with 3 in. meter opening. If you have the latter, you'll need to make an aluminum panel to cover the meter opening. If you have the blank panel drill holes

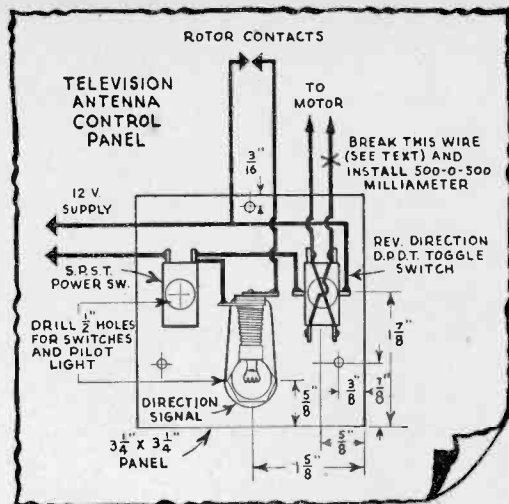

for switches and pilot light directly in the cabinet front. In either case, use control box dimensions given in the pictorial plan, plot and drill holes, and mount and wire components as shown.

In addition to the twin lead-in from the antenna, four additional weatherproof wires are brought down from the roof to the control box. Two of these wires supply power to the miniature motor while the remaining leads operate the signal light. When possible, install motor and signal light wires away from dipole lead-in, and run them at a near-right, downward-angle. Occasionally the television picture may blur when the antenna motor is started. However, this is not frequent, and not a problem, anytime. Should this happen, flip power switch *on* and *off*, and check picture intensity as you "inch" rotation of antenna. Flip both *power* and *direction* switches simultaneously for minute adjustment. Those who may wish to eliminate the *reverse*

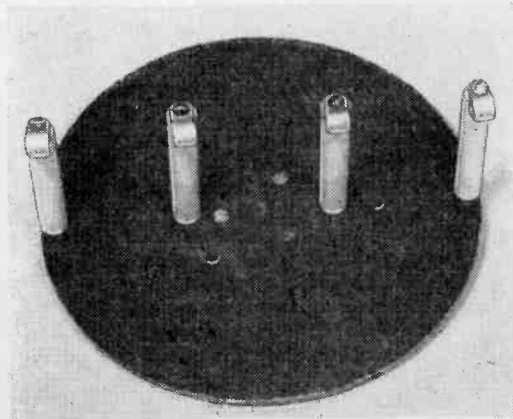

Close-up of Masonite disc with stand-off type porcelain insulators to which simple dipole antenna rods are fixed. Any standard television antenna may be fitted to disc.

signal light's wiring to have a "scientific-looking" control, can leave out pilot light (a 12 volt electric train type) and insert a small Shurite dc 500-0-500 milliammeter in its place on the panel. They should then connect meter terminals in series with one of the motor leads, and disregard present pilot lamp assembly and the wiring to it.

When motor is turned on, a deflection of meter needle will be noted, either to right or left of zero. However when motor reaches the stop screws, the stall will cause meter to draw more current. Meter needle will then swing far to left or right indicating that you must snap the direction switch. After switch snaps, needle will come back to a normal reading. The milliammeter also indicates whether or not motor is rotating the antenna, even without your looking at the television picture. However, the choice of a pilot light or a meter is up to the individual.

What about power for the miniature aircraft motor? It is a direct current, 24 volt, job. But many dealers handling these motors also have war-converted rectifier units for running off the 115 volt power line. If not, you can buy six or eight standard No. 6 Winchester, Burgess, Bright Star, or Eveready bell ringing cells. Connect them in series and attach with the 12 volt supply line. Although intended for 24 volts, miniature motor will rotate too fast on 24 volts even though it is operating through a built-in gear reduction. Depending upon the weight of the antenna, as little as 6 volts is ample. Moreover, dry cells will last about a year due to the infrequent drain placed upon them.

Following the general procedure and layout of the motor control, this system is readily applicable to motors which may be of larger diameter than the model illustrated. For example, a No. 2 metal food container (tomato can) may be fitted with a standard 3/4 or 1 in. pipe flange on the bottom so as to fit the antenna mast. Remove top of can on an automatic can opener. Fit opening with a wood disc, which also may serve as mounting for the motor. Secure wooden disc to container with four to six equally spaced wood screws and you have a perfect alternate system. However, coat container inside and out with asphalt paint as used on rotor disc.

### Drilling Holes in Metal

• When drilling holes in metal on all but the heavy type of drill presses, holes run out of true from .001 to .010. This is caused by a slight sag in the table or from using a heavy hand feed or both. Accurate holes can be drilled on most any drill press by turning the work in a complete circle on the drill table at least a quarter of the circle at a time and making at least one complete revolution. First drill a quarter of the depth; then turn the work a quarter of the circle; then drill another quarter depth, and continue following this procedure until the job is done.—JOHN EICHBERGER.



**HOLD EVERYTHING**  
Send today for your **FREE**

Catalog of parts specified in these construction articles — priced individually and in kits  
**ORDER from this list of typical RADIONIC VALUES**

#### CHOKES

Unshielded; 25 hy @ 60 ma. 59¢  
Unshielded; 15 hy @ 50 ma. 54¢

#### CONDENSERS

MICA. 10, 25, 50, 100, 250, 500, 1000 mmmf..... 26¢ ea.  
CERAMIC. 3, 5, 10, 25, 30, 50, 100, 140, 200, 500, 1000, 6¢ ea.  
PAPER TUBULARS. .005, .01, .02, .05, .1 (600V)..... 9¢ ea.  
ELECTROLYTIC. 20x20, 150V, 33¢ ea. 30x30, 150V, 37¢ ea. 40x40, 150V, 42¢ ea. 50x30, 150V, 52¢ ea. 8 mf, 450V, 50¢ ea. 16 mf, 450V, 62¢ ea. 10 mf, 50V, 24¢ ea. 25 mf, 25V, 27¢ ea.  
VARIABLE. 2 gang, cut osc. section., for 456 kc IF, with drum, 49¢ ea. 3 gang, 410 mmmf each section..... 69¢ ea.  
VARIABLE CERAMICS. 1.5-7; 4-30; 5-20; 7-45 mmmf, 18¢ ea.

#### MISCELLANEOUS

Super-het coil kit; 2 shielded IF transformers; 1 osc. coil; (specify 6SA7 or 6A8 type); 1 ant. coil; 1 RF coil. Kit, \$1.19  
WAFFER SOCKETS. 4, 5, 6 pin or octal, any type..... 5¢ each  
Miniature wafer type, 6¢ each

#### RESISTORS

Half watt; 10% tolerance, insulated, axial leads, 100 ass'td. \$2.50. One watt, as above, 100 ass'td..... \$3.75

#### TRANSFORMERS

Shielded, upright mounting type. 550 vct @ 60 ma; 6.3 vct @ 2A; 5 v @ 3A. Majestic. \$1.69  
Shielded; universal mounting, 750 vct @ 70 ma; 6.3 v @ 3A; 5 v @ 2A..... \$1.99  
Shielded; universal mounting, 700 vct @ 100 ma; 6.3 v @ 4A; 5 v @ 3A..... \$2.45

#### POTENTIOMETERS

CARBON. 500 ohms thru 10 megohms. All values, 26¢ ea.  
WIRE WOUND. 1 ohm thru 10,000 ohms. All values 26¢ ea.

#### TUBES

Fully guaranteed—individually boxed. 12SA7GT, 12SK7GT, 12SQ7GT, 12AT6, 12BA6, 12BE6, 35W4, 50B5, 1R5, 1S5, 1T4, 1U5, 3Q4, 3S4, 6SA7GT, 6SK7GT, 6SQ7GT, 6V6, 6SJ7GT, 34¢ ea. 50L6GT, 65¢. 35Z5GT, 49¢. 6SN7GT, 12SN7GT, 34¢ each.

TERMS: 20% deposit with order, balance C.O.D.

MOST ORDERS SHIPPED SAME DAY AS RECEIVED

**RADIONIC EQUIPMENT COMPANY**

Tribune Theater Entrance

170Z Nassau Street :: New York 7, N. Y.  
Worth 2-0421 :: Open daily 9 to 6—Saturday 9 to 5

**MAIL TODAY!**

RADIONIC EQUIPMENT COMPANY, Dep't 8050  
170 Nassau Street, New York 7, N. Y.

Gentlemen:

RUSH your FREE Catalog of parts specified in RADIO EXPERIMENTER for the construction of: .....

..... on page.....  
..... on page.....  
..... on page.....

RUSH your latest Flyer containing BIG VALUES in Radio and Television Parts, Tubes and Accessories

NAME.....  
ADDRESS.....  
CITY..... STATE.....

# Converting a Table Radio into a RADIO PHONOGRAPH

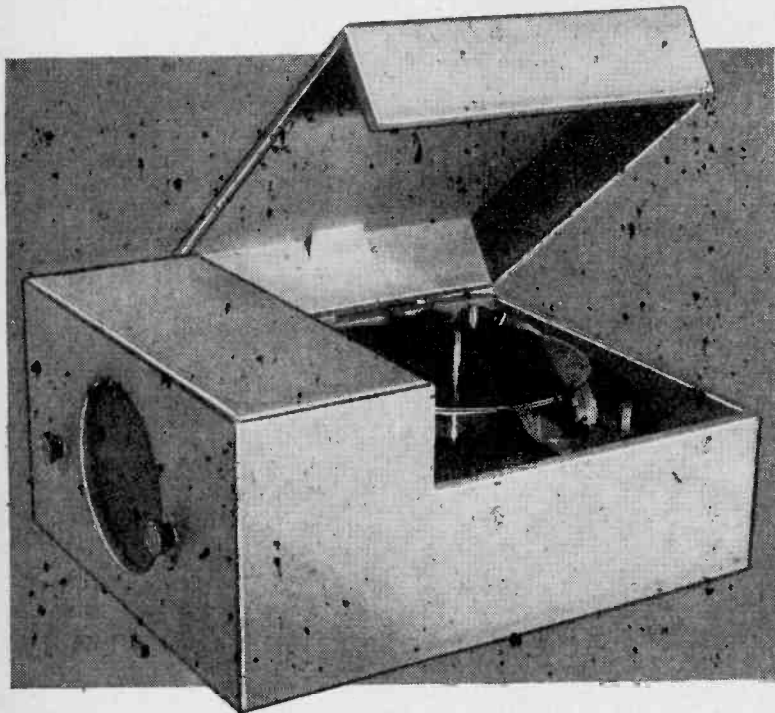

Try this two-in-one reconversion job. It will give you an attractive combination set

By JOHN C. DODD

**Y**OU can amaze yourself and your friends by installing your old table-radio and an inexpensive automatic record-changer in this easy-to-make leatherette-covered case. And you don't need an extensive shop—a few simple tools do the trick. The phonograph pickup leads can be connected to any set easily. So let's go to work and make it.

The record-changer, phonograph-motor and electrical pickup can be purchased as a unit from almost any radio supply house for (at last quotation) \$18.50. You'll find 1¼ yards (50-inch wide) of leatherette in a variety of colors at the department store for \$2.50. A .02-mfd. tubular condenser and hinges take up the remaining 50c. The case illustrated was made from scrap packing-case lumber with the nail holes and defects filled with plastic wood.

The first step in construction is to determine the basic dimensions of the case from the template supplied with the record-player mechanism

and the radio chassis cabinet (see drawing). Next, cut lumber to size and attach ½ x ½ inch strips to form rabbets as shown. If you have some scraps of ¼ inch plywood suitable for the top and bottom it saves the joining and gluing of narrow boards. Masonite may be used for the mechanism platform and the baffle. Complete box-like case by gluing and finishing joints. Saw out lid. The saw kerf will allow just enough space to be taken up by the two layers of leatherette so the lid will fit back into exact position. Saw out suitable opening to fit speaker. This opening may be covered from the back with cloth or screen wire. Locate and make openings for radio controls.

Cover outside and visible inside surfaces of case with leatherette using ordinary carpenter's glue as an adhesive. Start and end seams at

back of case. If this is your first attempt at covering it is a good idea to practice making a few cuts, joints and corners with wrapping paper before using the material.

The record-player and pickup is connected to the radio before either is placed in the cabinet. Turn radio up-side down and remove bottom plate from chassis. Connect phono-motor wires by tapping into radio's line cord. Plug line cord into wall socket. *Do not touch any connections under chassis with bare fingers as some voltages may be as high as 250 volts.* Turn on radio and place tuning control at an off-station position with volume control full-on. Turn record-player's switch to ON position. Place a record on turn-table. Apply pickup to record. The record's sound vibrations are now being converted into electrical energy which is flowing in the wires coming from the pickup. One of these wires (ground) is soldered to the chassis of the radio. Solder the other wire to one of

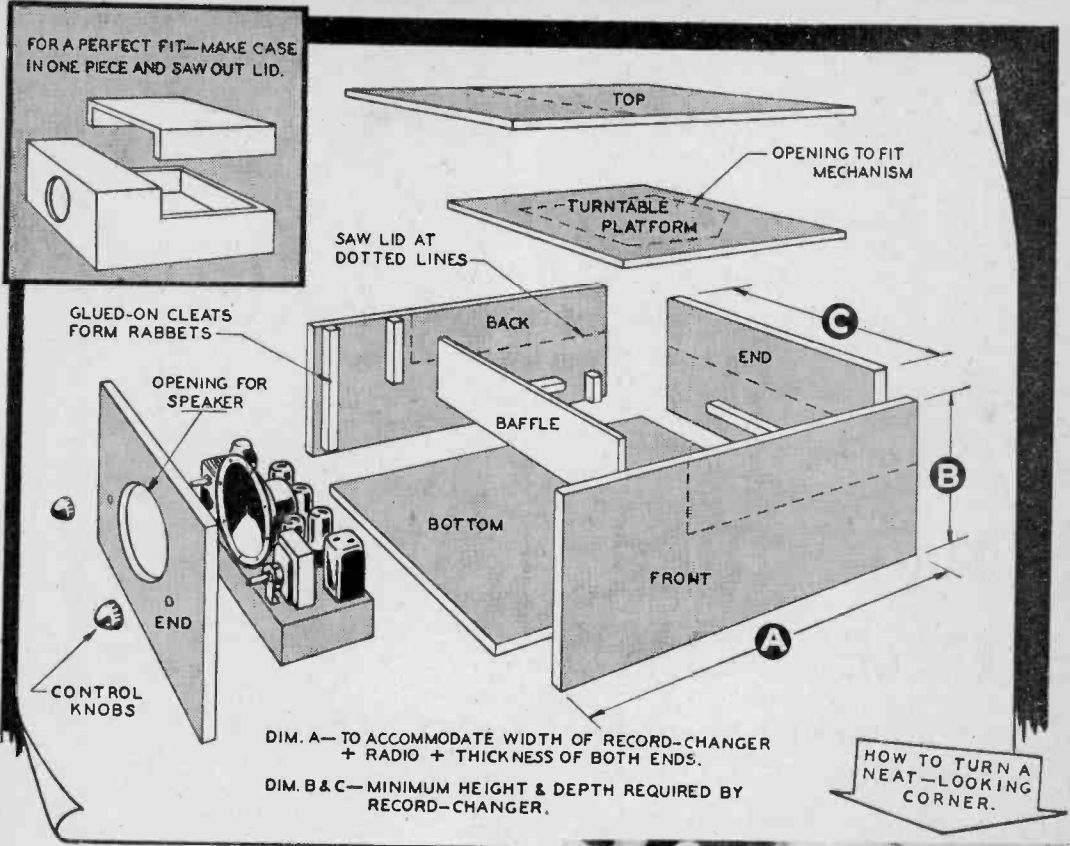

the leads on the tubular condenser. Then, using the other lead of the condenser as a probe, with the record still playing, touch the connections around and near the volume control. When you find the right location, sound will come out of the speaker. Try other connections to determine if you have the one that will give the best reproduction and response to the volume control. Disconnect plug from wall socket and solder condenser lead to the connection you located. Install radio and record-player in case. When playing recordings tune radio to an off-station position. For radio programs turn off record-player and tune in the station of your choice.

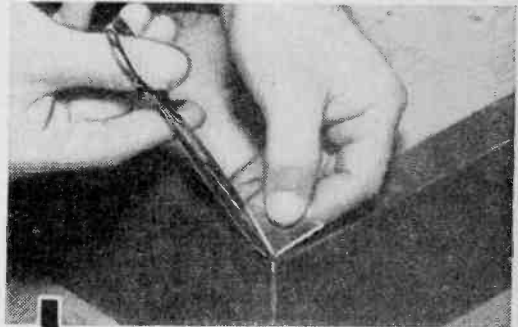

Glue material to sides allowing a 1-inch overlap. Cut out 90° V-notch at corner.

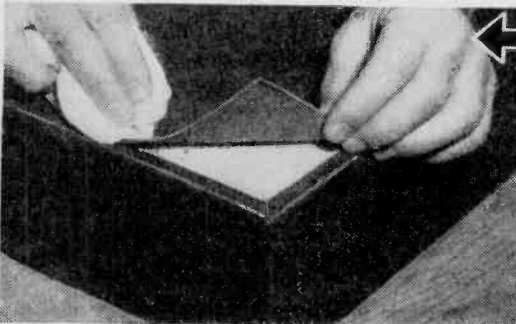

Cut top cover  $\frac{1}{16}$  inch smaller on all sides and glue to surface of case.

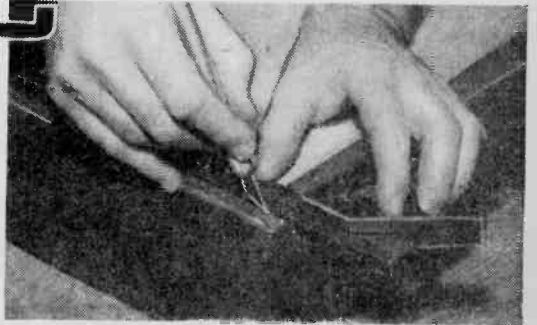

Glue overlap to surface of case. Trim evenly  $\frac{3}{8}$  inch from edge.



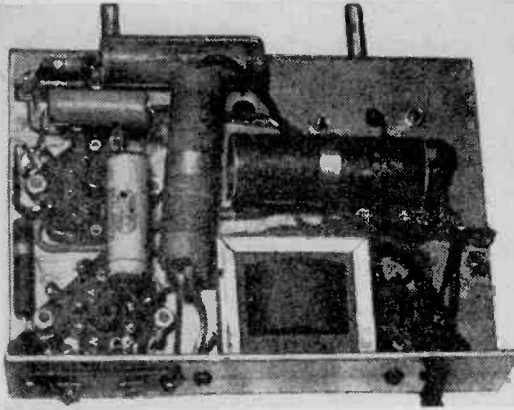

Bottom view of the intercommunicator showing filter choke, filter condensers, by-pass condensers and resistors, and the line cord.

## TWO TUBE INTERCOM

You'll find this a very handy servant for either home or office use

By ADOLPH SUCHY

ONE of the most useful pieces of electronic equipment around the home or office is the intercommunicator. You can use it to connect the nursery to the bedroom (to notify mother when baby is restless) or to connect the home workshop to the kitchen (to notify hobbyist husband that soup's on), or as a connection from the sick room to kitchen or other parts of the house. Some uses in commercial offices, factories or stores are as an announcing system in restaurants, a call system to the stock room or coal yard, or as an efficient interoffice communications unit.

The basis of this unit is the chassis, which is made from a 6x8 inch sheet of aluminum. This is deeply scored along the lines indicated in the drawing and bent as indicated. A complete layout of the chassis is shown in Fig. 1. This layout may vary somewhat with the parts purchased, but the general placement of the parts should remain the same as

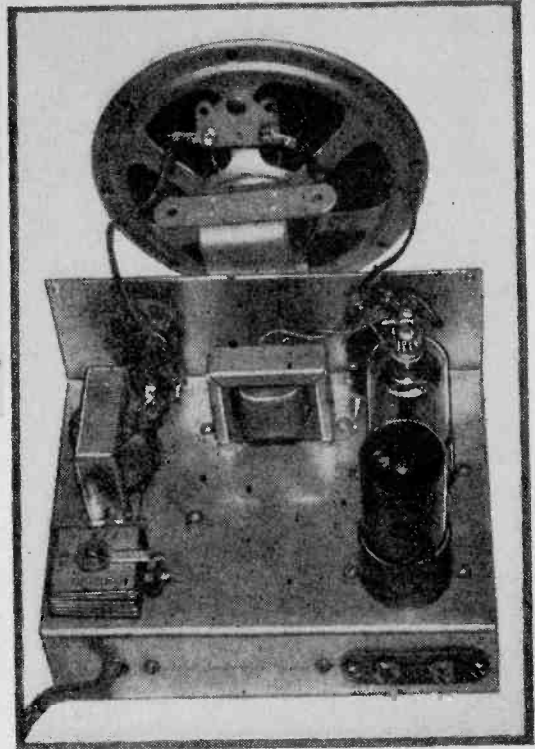

Top view of the intercommunicator showing the talk-listen switch on left of front apron, the volume control on right of front apron, the input and output transformers, selenium rectifier, tubes and speaker.

there has been considerable design work done to eliminate hum. This chassis is mounted in the cabinet by placing two wood screws through the holes in the upper corners of the chassis.

The circuit used in this amplifier consists of a

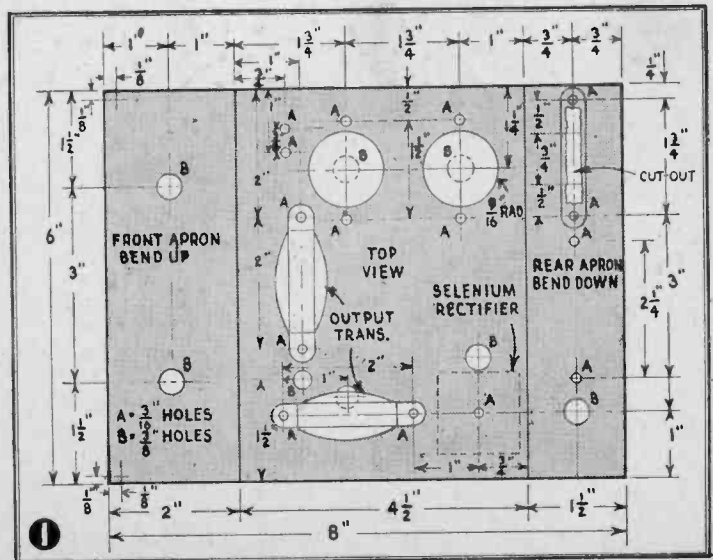

pentode high gain voltage amplifier (6J7 tube), a beam power output tube (25L6), and a selenium rectifier. A rectifier tube may be substituted for the selenium rectifier, but the new selenium rectifier has the advantage of not having a filament which can blow and cause trouble. Therefore, the constructor can expect longer troublefree service from the unit. It will be noticed that two output transformers are incorporated. One of these is used as the usual output transformer in the set while the other is connected "backwards" from the way one might expect. The secondary of both transformers terminates at the double pole double throw talk-listen switch. On the input transformer, (the output transformer connected to the volume control) the leads that normally go to the plate and B positive are connected to the volume control. The double pole switch used in this intercom was one with a spring return so that the master station is always in the listen position. It is then possible for the remote station to call the master station at any time and the master station can call the remote

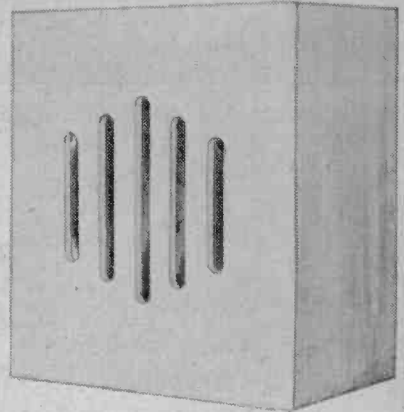
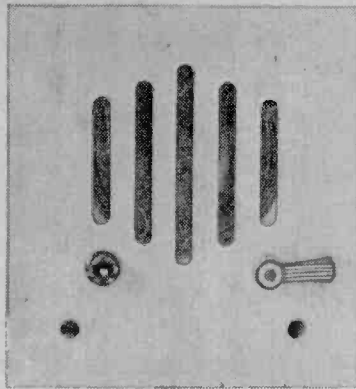

Front view of mounted intercommunicator. Master station is shown at left. Left knob is for volume, right is push to talk switch.

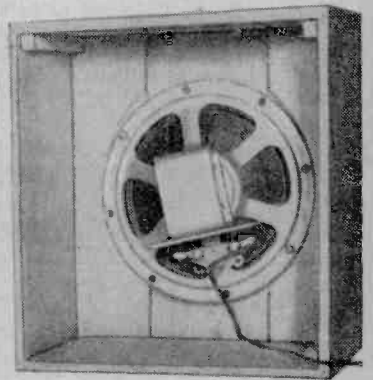
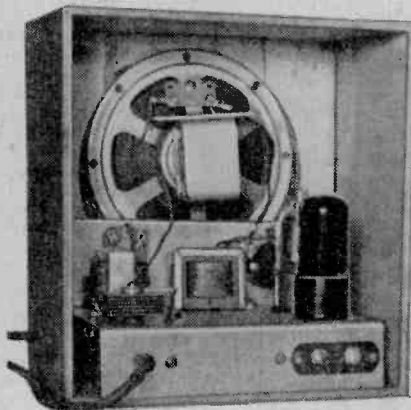

Rear view of intercommunicator mounted in cabinet. Master station is at left and remote station consisting of a speaker is at right.

by depressing the switch and calling. A wafer type switch is preferred, as it is one which completely breaks contact before making on the opposite pole. A long knob commonly used in intercoms is desirable to use for ease of operation.

To construct, first lay out chassis, and bend, drill and punch as indicated in Fig. 1. Next mount the parts. With the back of the chassis facing you the volume control is mounted in the right hole of the front apron. The talk-listen switch is mounted in the left hand hole. The transformer parallel to the front apron is the input transformer and is connected to the volume control. The filter choke is mounted on the rear apron in the two holes provided for mounting.

Draw line cord through hole in rear apron and knot, leaving

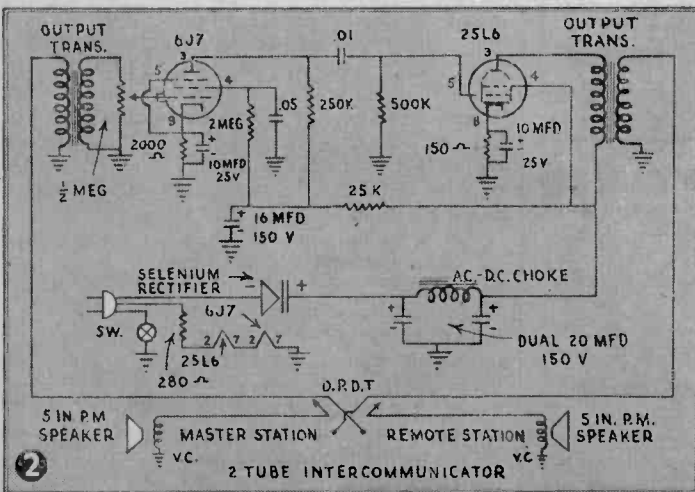

## SURPLUS BARGAINS

### COMMAND RECEIVERS

Used, Good

A terrific radio value for all "hams" and experimenters. Priced at but a fraction of government cost!

BC453—1.9-550 KC ... \$12.95  
 BC454—3-6-MC ..... 5.95  
 BC455—6.9.1-MC ..... 6.95  
 6 1/2' CONTROL CABLE  
 for above command  
 sets ..... 1.00

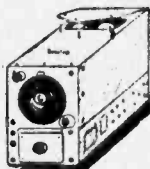

### C & H WAR SURPLUS CATALOG



... jam-packed with values galore for the factory, home, workshop, farm and outdoors! New, used and reconditioned items priced amazingly low! An unusually large listing of surplus radio bargains.

Send  
10c  
Today!

Enclose money with order. All equipment FOB Pasadena.

## C. & H. SALES COMPANY

Dept. RE-1 • 2176 E. Colorado St. • Pasadena 8, Calif.

# Inventions Wanted!

**GET CASH FOR YOUR IDEAS.** New products, devices and commercially sound ideas, patented or unpatented, now in greatest demand. Big illustrated 32-page Bulletin, "When, How and Where to Sell your Invention," contains names and addresses of 100 hand-picked firms ready to pay cash or royalty for acceptable ideas, together with detailed information of what they want to buy. You may have the very thing one of these 100 firms is looking for. Cash-in on your ideas now! Bulletin also gives valuable, practical data on best methods to follow in making a sale, including sample of successful sales letter; tells how to prepare "Functional Statement" of invention's advantages; gives pointers on getting best price; kind of sales agreement that protects you; many more facts that other inventors have had to learn the "Hard Way." Wanted are new ideas for auto accessories, household items, radio equipment, air conditioning, electronics, toys and games, gadgets, farm implements, many others. Send \$1.00 today for this Bulletin. Examine for 5 days at your leisure. If not delighted, return for immediate refund. **ACT NOW!** Science and Mechanics Magazine, 450 East Ohio Street, Dept. R-4, Chicago, Ill.

## Parts For TELEVISION RECEIVER

We can supply you with all parts for building the television receiver described in this handbook.

All parts are especially designed for this circuit.

You are sure to get the best results by using **CERTIFIED** parts that have been used in thousands of kits and manufactured television receivers.

All parts available—from drilled chassis to the smallest resistor.

Parts fit mechanically—electrically correct.

Save Time—Save Money—Save Your Temper

Write For Free Price List

**Certified Television Laboratories**

Dept. S, 5507 13th Ave.,

Brooklyn 19, N. Y.

sufficient lead to reach necessary terminals. Wire the line cord, switch and filament circuit. Connect the line cord to the unmarked terminal of the selenium rectifier.

Then wire the filter and B positive circuits. Be careful to observe the polarity on the filter condensers.

The next step is to wire the plate and screen circuits. These are numbers 3 and 4 on the socket terminals of both tubes. In determining the numbers of the socket pins, look at the bottom of the socket and begin counting at the pin to the left of the keyway. This is pin No. 1 and the pins are numbered consecutively by counting

### PARTS LIST

- 1 piece aluminum 6" x 8" for chassis
- 2 25L6 to voice coil output transformers
- 1 selenium rectifier (Federal)
- 1 280 ohm line cord
- 1 1/2 megohm volume control with switch
- 1 dual 20 mfd. 150 volt or higher electrolytic condenser (tubular)
- 1 16 mfd. 150 volt condenser (tubular)
- 2 10 mfd. 25 volt electrolytic condensers
- 1 .05 mfd. 400 volt condenser tubular paper
- 1 .01 mfd. 400 volt condenser tubular paper
- 1 ac/dc choke
- 1 500k ohm 1/2 watt resistor carbon
- 1 250k ohm 1/2 watt resistor carbon
- 1 25k ohm 1/2 watt resistor carbon
- 1 2k ohm 1/2 watt resistor carbon
- 1 150 ohm 1 watt carbon resistor
- 2 megohm carbon resistor 1/2 watt
- 2 water octal sockets 1 1/2" mounting centers
- 1 spring return double pole double throw wafer type switch
- 2 5" permanent magnet speakers
- 1 cabinet for master station
- 1 cabinet for remote station
- Screws, nuts, wire, solder

clockwise. Wire the cathode circuits of both tubes. These are the numbers eight on the sockets. Be careful again to observe the polarity on the electrolytic condensers used in this circuit.

Next wire the grid circuits. On the 6J7 the grid is the cap on the top of the tube. This is wired directly to the volume control to which it is adjacent. Looking at the rear of this control, the grid cap is connected to the center terminal. The ground is connected to the right hand terminal and the transformer leads to the outside terminals, the blue lead to the left terminal and the red lead is grounded. The connections to the grid of the 25L6 are self evident.

Use extreme care in wiring the talk-listen switch or the unit will not operate. The switch is a double pole double throw switch in the diagram. If a wafer type switch is used look at the switch and determine the arms. Then rotate the switch and observe which contacts make at the same time. Then proceed to wire. Both transformers have enameled wire coming from the voice coil winding. Be sure to clean these wires thoroughly before attempting to solder the connections.

Now mount the units in their respective boxes. The master station will contain the tubes and the remote station will have nothing but a speaker. A dual conductor line is now run from the remote speaker to the master station and connected to the proper terminals. This line may be of ordinary twisted pair fixture wire or

zip cord. The runs from speaker to remote station should not exceed 150 feet. If the remote speaker is placed near the master for testing purposes the volume control should be advanced very slowly as the sound vibrations will feed back from the remote station to the master and cause it to howl.

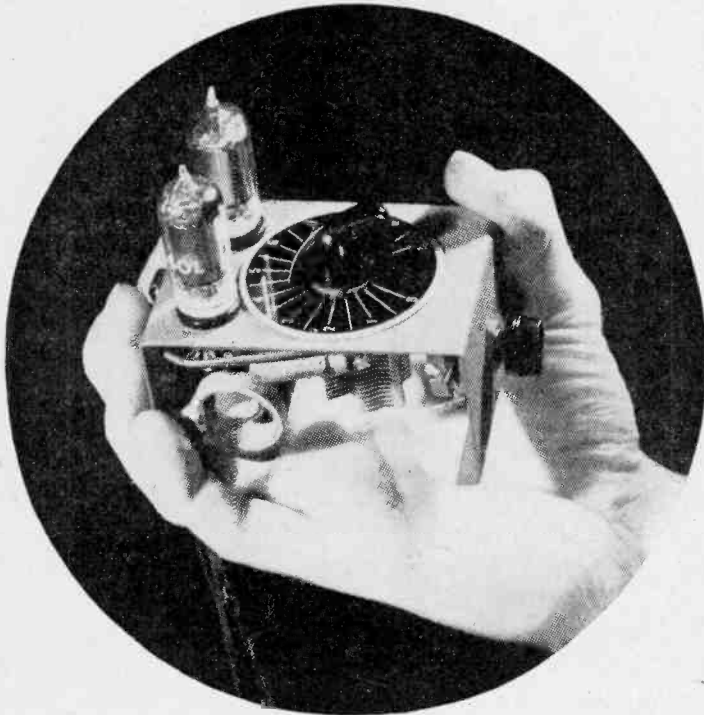
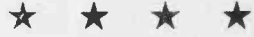

# MINI-BATTERY SET

## Packs Surprising Power

By  
**THOMAS A. BLANCHARD**  
Electronics Engineer

**T**HIS set follows the same simple chassis design as the original 3-in-1 set, except that the size has been reduced two-thirds. A piece of aluminum or steel is obtained that measures 2 5/8 by 7 1/2 inches. After drilling a pair of 5/8-inch holes for the miniature tube sockets, openings in rear for phone terminals and cord, and two 3/8-inch holes

for tuning condenser and potentiometer respectively, the chassis is bent to the shape shown. A 1/4-inch fold at each end provides for feet. Two more bends, 1 3/4 inches from the feet, complete the forming operation producing the result pictured here.

There is of course no hard and fast rule on design. You may build the set according to your own desires (even in a cigar box) just so long as you adhere to the circuit *exactly* as given.

The tube or tubes selected for this set are 1T4 Pentodes. Aside from being readily available, and inexpensive, they are of the low current type used in many hearing aids. That means that the set can be used for hours on a single penlite A battery. Or using a regular hearing aid A battery, about 60 hours or more use can be expected. A No. 6 dry cell would last many weeks. The miniature 45 volt B battery will be serviceable for several months under average use, you will find.

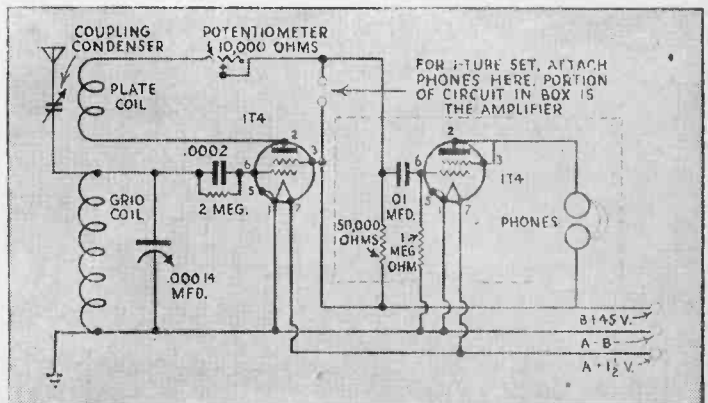

Schematic diagram of the potent midget receiver.

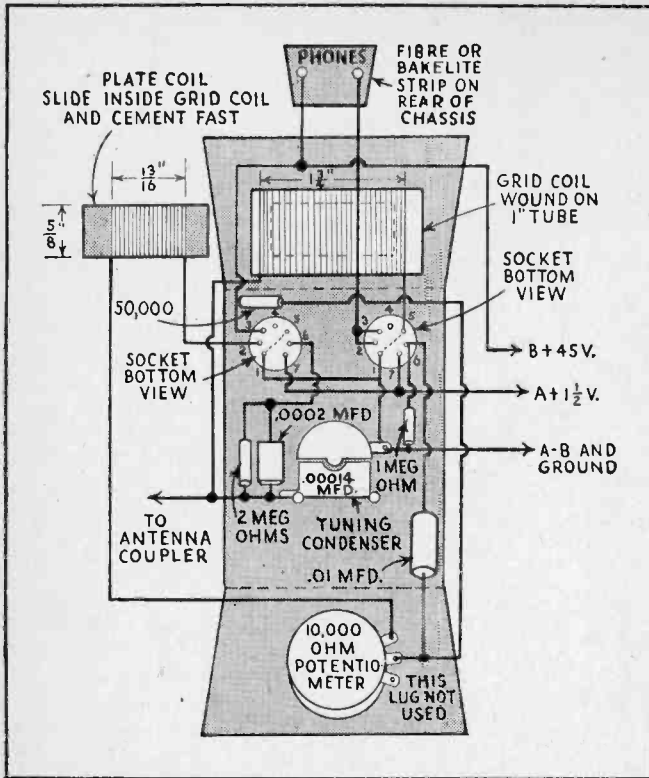

Pictorial diagram with key components in white.

Following the pictorial diagram, the parts may be mounted as shown. All parts are standard except the coils, which are homemade. The smaller, or plate coil, is wound on a length of  $\frac{5}{8}$  inch diameter paper tube with No. 30 enameled magnet wire. Measure off a  $1\frac{3}{16}$  inch space in the center of the tube, and starting at the lefthand side and turning the tube away from you as you wind, fill the measured space with an even layer of wire. A pinhole pierced at each end of the tube, permits the wire to be passed through to anchor it. Coil may be doped with model airplane cement to secure the turns.

The larger, or grid coil, is wound on a 2 inch length of paper tube having an outside diameter of 1 inch. Measure off a space  $1\frac{3}{4}$  inches and wind on this tube an even layer of wire to fill the space, securing wire with cement as previously described. Again in this instance, start coil at left and wind by turning coil form away from you. Both coils must be wound in the same direction, and coil connections must be made exactly as shown in pictorial plan or the set will not work properly.

#### LIST OF MATERIALS

For 1-tube set

- 1 metal chassis (see text).
- 1 midjet variable condenser (.00014 mfd.—APC type).
- 1 midjet fixed condenser (.0002 mfd. mica).
- 1 antenna coupling condenser (see text).
- 1 miniature tube socket.
- 1 10,000 ohm potentiometer.
- 1 2 megohm resistor ( $\frac{1}{2}$  watt).
- 2 phone terminals.
- 1 coil assembly (see text).

For two tubes add:

- 1 miniature tube socket.
- 1 .01 mfd. paper condenser.
- 1 50,000 ohm resistor ( $\frac{1}{2}$  watt).
- 1 megohm resistor ( $\frac{1}{2}$  watt).

Plus, for either set:

- 1 miniature 45 volt hearing aid battery (B).
- 1 miniature  $1\frac{1}{2}$  volt hearing aid battery (A).
- 1 or 2 Type 1T4 miniature pentode tubes.
- Miscellaneous hardware and hookup wire.

A hole in the unused end of the larger coil allows it to be mounted, using a spacer and machine screw to the rear apron of chassis. The smaller coil is slipped inside the larger coil and secured with glue. Leads from the coils are then soldered into the circuit as shown. Fine sandpaper will remove very nicely the insulation from the enameled

wire used in the coils.

A 10,000 ohm potentiometer in the front apron of the chassis controls the sensitivity of the set. Turned to the extreme in one direction, the set





will oscillate so that weaker stations will be recognized by a whistle. Retarding this control will clear up reception. It also serves as a volume control for more powerful stations.

Those interested in the more powerful two tube set may follow the pictorial plan throughout. If you choose the single tube version, a glance at the schematic drawing will show a section of the circuit enclosed in dotted lines. This

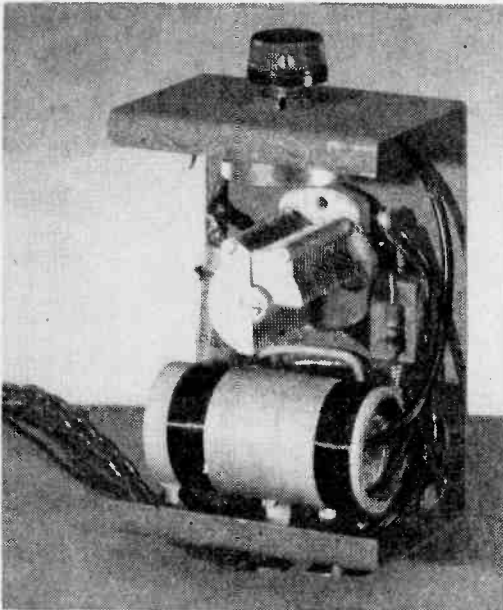

Underneath view of mini-battery set showing home-wound coil and other components.

is the amplifier, and is disregarded. Earphones should be connected as indicated previously for the single tube operation.

When used as a one tube set, it may be desirable to slide the small coil in and out to find the best position, before cementing it fast. Or, for the sake of experiment, you can short out the potentiometer altogether, and move the small coil in and out to control regeneration. In so doing, don't shift the coil directly, but cement a lollipop stick to it so that body capacity does not upset the tuning.

Another interesting trick is the super-regenerative feature of the detector circuit. We have obtained reception with as little as 6 volts B battery supply; this was provided by four penlite cells connected in series. A fifth penlite cell served as A battery. When using such a small amount of power calls for additional turns on the small plate coil, we would suggest you wind about an inch of wire on the tube, sliding it in and out as previously described.

Our schematic circuit shows a coupling condenser in the antenna lead. This may be made by twisting together tightly two pieces of insulated wire for a distance of 1 to 2 inches. Attach the bare end of one wire to the set and the other

clips on the dial phone, outdoor aerial, etc. A coupling condenser may also be fashioned from two pieces of tin, 1/2 inch square. Place a 1/2 inch square of cardboard between, solder a lead to each tiny plate, and tape the three together.

The 1T4 tubes are connected internally so that pin #1 and #5 of the filament are common to each other. Therefore A-B lead may be wired to either #1 or #5 pins.

The set as described will tune in all of the broadcast band. Stations at the lower end of the dial, will require a little less coupling in the antenna circuit, either fewer twisted turns of insulated wire, or more cardboard between the small metal plates. Stations near the top of the dial require reverse treatment—less gap between the plates by replacing the cardboard with paper or cellophane. If the wire coupling is used, more turns are used.

This set will operate several pair of headphones (connect them in series) as well as a small PM speaker with very good results. We obtained surprising speaker volume on distant stations—earphone volume so loud it had to be throttled down. These results may be considered as average. Certain locations may provide even better success than we had. In other locations reception may be limited to headphones, which however, have ample volume.

Our results with the one tube version proved very satisfactory. In many localities, with a good antenna, speaker operation can be expected with the one-tube set.

### Insulating Wires

ON ELECTRICAL work, the home craftsman is normally at a great disadvantage when it becomes necessary to insert wires in Irvolite and other types of flexible insulation tubing—especially when tight fits and neat appearance are essential. Accompanying drawings indicate a tool and a method with which this disadvantage may be overcome.

The tool is a vise-like gadget whose jaws are arranged to open and close the two halves of a

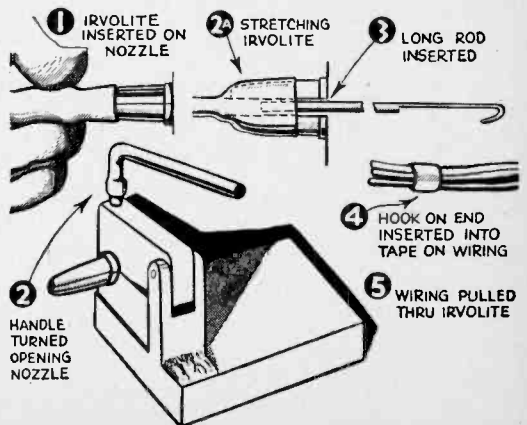

tapered nozzle. Up and down adjustments of the jaws and nozzle are accomplished manually with a handle and screw mechanism.

When the nozzle halves are in contact with one another, the flexible insulating tube can be easily slipped over their outer surfaces. Then,

when the nozzle halves are separated, the mouth of the tube is stretched open.

The wires that are to be insulated should then be taped together so that they can be pulled into the required position with a rod-hook through the stretched tube end.—T. A. DICKINSON.

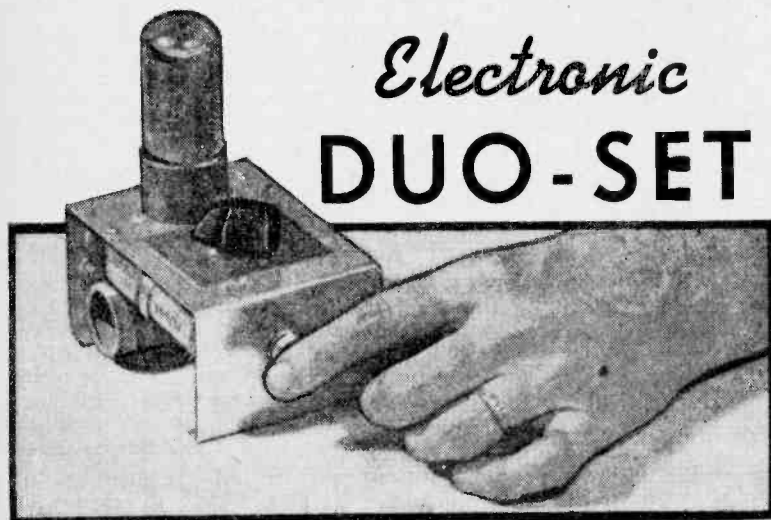

Switching on this versatile little one-tuber. It will operate from either 115 ac or dc, is designed for earphones but can use a speaker.

A few simple alterations will convert this miniature radio into a wireless broadcaster

By T. A. BLANCHARD

**H**ERE is a one tube radio project that is in many ways similar to the Three-in-One Electronic Set. The exceptional amount of interest aroused by this set led us to redesign the original 2-tube set into a one-tube project. Aside from being simpler to build, we think this new version is an even better performer. A novel feature is that this is a one-tube, all-electric radio operating from either 115 volt ac or dc. Without any extra expense, the set may be changed over so that it becomes a miniature radio transmitter and will play records through regular radio sets without any form of direct connection.

As a personal set, it is just the thing for listening to late evening broadcasts in bed, without disturbing others about the home. Designed for earphone use, it will operate a speaker if you live within range of the more powerful stations. The set is tiny, but nevertheless easy to wire. It can be taken on trips, etc. since it is scarcely larger than king-size cigarettes. We believe this set will be of particular interest to the many teachers, students, and experimenters who have written us about the good results obtained with the larger and more complicated version.

The chassis is formed from aluminum or

steel. Because of its rigidity, steel is first choice, though more difficult to bend and drill than aluminum. If aluminum is used, choose a gage not less than No. 16 B & S for ample strength. Start the chassis with a strip of metal measuring  $8\frac{3}{4}$  in. long, and 3 in. wide. Scribe each end of the chassis,  $\frac{3}{8}$  in. from each end, and again  $2\frac{3}{8}$  in. Now bend the chassis at these points to form the channel-shape shown. Arrange the components and provide a  $\frac{3}{8}$  in. hole in the center of the front apron for the volume control. In the rear apron, make another  $\frac{3}{8}$  in. hole

for the power cord, as well as an opening for the phone or crystal pickup connection. Cut a 1 in. hole for the 8-prong octal tube socket on the top of the chassis. Then below it cut another  $\frac{3}{8}$  in. hole for the tuning condenser. The exact locations for the various holes are best determined after all parts are on hand.

#### KEY AND MATERIALS LIST—DUO-SET

##### CHASSIS

Form from aluminum or steel No. 16 gauge. A  $8\frac{3}{4}$ " by 3" strip is formed into a 3" by 4" x 2" channel.

##### CONDENSERS

- 1 140 mf tuning condenser (A)
- 1 140 mf fixed mica condenser (D)
- 1 20-20 mf electrolytic condenser (midget 115v.) (C)
- 1 0.1 mf paper condenser (optional, see text)

##### RESISTORS

- 1 25,000 ohm potentiometer (B)
- 1 10,000 ohm,  $\frac{1}{2}$  watt resistor
- 1 1,000 ohm,  $\frac{1}{2}$  watt resistor
- 1 2-meg ohm,  $\frac{1}{2}$  watt resistor

##### MISCELLANEOUS

- |                        |                                    |
|------------------------|------------------------------------|
| 1 small bar knob       | 1 coil form, 1" dia., .3" long (H) |
| 1 knurled knob         | 1 octal tube socket (E)            |
| 1 length fixture cord  | 1 117L/M 7GT tube                  |
| and plug (G)           | Misc. hardware and hook-up wire    |
| 1 pair phone clips (F) |                                    |

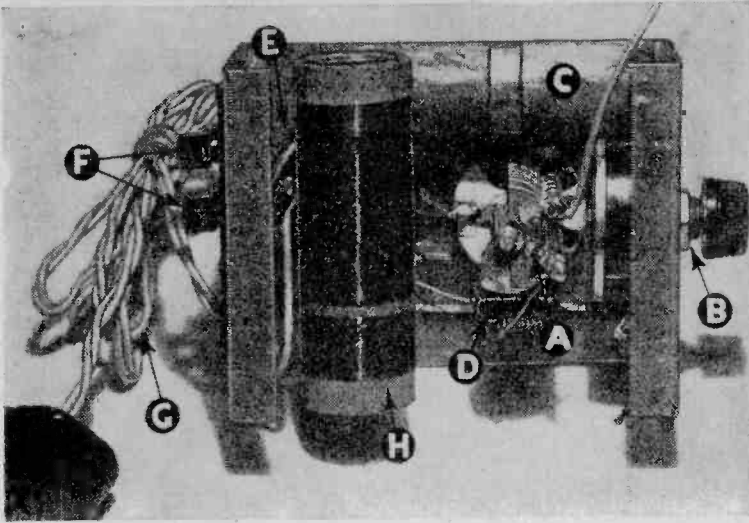

The coil is wound on a form 1 in. in diameter and 3 in. long. Both  $L^1$  and  $L^2$  are of No. 30 enameled magnet wire. Starting  $\frac{1}{16}$  in. in from the edge of the coil form, wind 45 turns of wire. Now you have wound Coil  $L^1$ . Allow  $\frac{1}{8}$  in. space and wind Coil  $L^2$  for 155 turns. With this winding completed, you will have a  $\frac{1}{16}$  in. space left at both ends of the coil form. This will allow sufficient room for mounting the coil on spacers under the chassis. It is important to note that both  $L^1$  and  $L^2$  must be wound in the same direction; otherwise the set will not perform. If set with coils properly wound fails to oscillate, reverse connections to  $L^1$ .

Mount and then wire all components with resin-core solder. Leave coil until last. The electrolytic condenser is held secure by a metal strap inserted under one of the two screws supporting the tuning condenser. This condenser is of the ultra-miniature 20-20 mf. size. Larger units will

not fit and the proper size must be obtained to insure its fitting in the allotted space to the right of the tuning condenser.

The diminutive size of this set was made possible by using a single tube operating directly on 115 volts and containing the elements of two tubes: a power pentode, and a half-wave rectifier, in one glass envelope. Examination of the pictorial diagrams will show the simple changes necessary to switch from a radio receiver to a real peanut-powered transmitter. When used as a transmitter, it is sometimes advisable to insert a .1 mf. condenser in the "pickup" lead as shown to prevent the rare possibility of a shock if: (1) pickup has metal arm, and you (2) are holding on to a water pipe, standing on steel

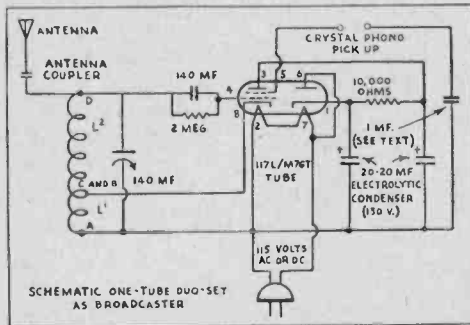

below—Attach unneeded end of L<sup>1</sup> to socket pin No. 3.

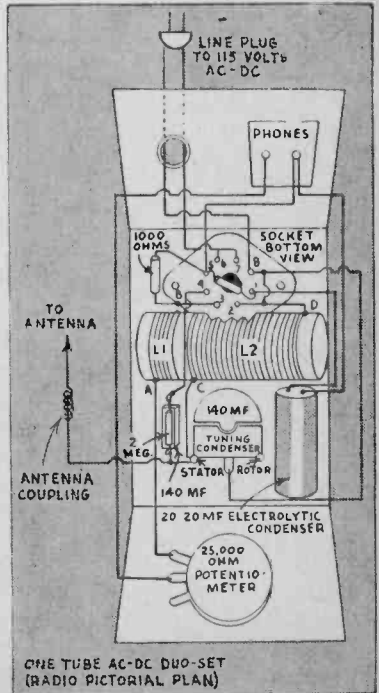
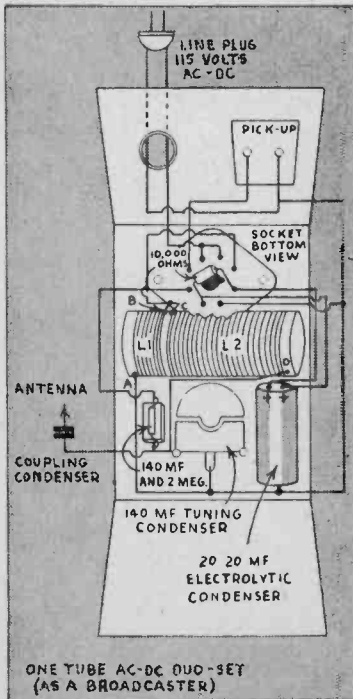

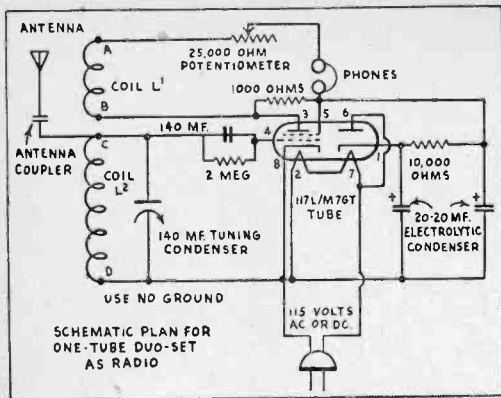

floor, etc., and in contact with both.

The above may sound fantastic, but these things sometimes do happen. You can otherwise connect a solid lead where this condenser is shown in schematic. (It is not shown in the pictorial plan. It is important, however, that you do not attach a ground wire into the circuit. If line polarity is not in your favor, you will burn up the coil, and probably blow the house fuses, too. The set is automatically grounded through the power line—as good a ground as you'll find anywhere! In some instances, body capacity may have de-tuning effects on the set. If you find the set acting up when you touch the chassis, simply attach a ground wire to the chassis, but to no part of the wiring.

Usually this 2-in-1 Set performs well by placing a few inches of insulated antenna wire under the base of a telephone, or direct connection (bare wire) to bed springs, window screen, etc. Where a longer antenna is used of conventional type, twist the insulated lead-in around insulated L<sup>2</sup> lead a distance of several inches from the set to form a suitable coupling. Never make any direct connections from set antenna lead to telephones or other electrical devices.

Used as radio receiver, the volume control is turned so as not to produce any oscillations in phones. Tune slowly, as many stations may be missed by hasty tuning. With station tuned-in, the volume control may be readjusted for more or less signal strength. Used as a broadcaster, only the tuning condenser is used in the circuit. Turn on regular home receiver, setting dial at a point below 1300 KC where no station is heard. Now slowly tune your little broadcaster until you hear its "carrier signal"—a humming sound—through the loudspeaker. With a phonograph pickup attached to the broadcaster, music will be transmitted through the regular home set with surprising volume and clarity. When using the Duo-Set as either radio or transmitter, it will be found it works better with power plug in one certain position. Reverse plug in line outlet to determine proper polarity.

## Wire Screen Serves as Signal-Booster for Loop

• To increase signal pick-up when a portable receiver is being used in a steel building, connect a regular outdoor antenna to some large insulated metal surface in the room, such as to a copper screen placed under the rug, or to a piece of screen tacked under the table on which the receiver is most often used.

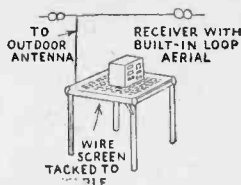

## Handy Wire Peeler

• A piece of spring steel or an old hacksaw blade with the teeth filed off, measuring 7" long by 1/2" in width, makes a handy wire peeler. Cut a "V" in each end 1/4" long and file on one side only of the "V" notch, tapering it like a wood chisel. Emery cloth all burrs and bend the spring steel or hacksaw blade into a horseshoe shape. When wire is to be peeled, slight pressure will cause the jaws to cut through the insulation, and by giving the peeler a half turn, the insulation is cut and the wire bared.—BARNEY M. JENSEN.

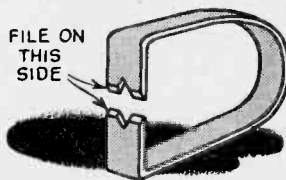

## Four Lamp Traffic Light

• A traffic light that operates with only four lamps, eliminates the amber warning signal, and needs no time switches, has been patented by Frank T. Powers of Glen Cove, New York. The essentials—two pairs of lamps mounted on shaft at right angles, on shaft turned at proper time intervals by motor mechanism in base. Each lamp is enclosed in parabolic reflector and covered by red or green lens or filter.

## Pencil Clip Secures Screw to Driver

• A screw-holding screw driver is easily made by adding an ordinary metal pencil clip to the driver, as shown, so that it will hold the head of the screw while it is being placed

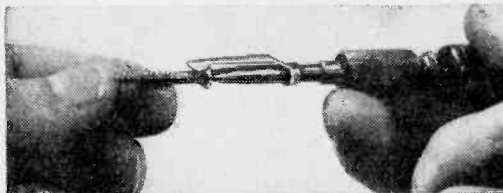

in position for driving. It will probably be necessary to bend the arms of the clip with pliers so that it will grip the smaller driver shaft. Pull clip back out of way when not in use.—K. M.

# Selective, Fixed Detector CRYSTAL SET

Try this new-type crystal set. It really separates the stations, even in the big city

By N. J. RUBENS

Engineering Division, Allied Radio Corporation

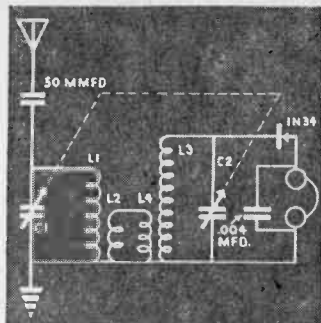

## LIST OF MATERIALS

- 1 1N34 diode detector
- 1 2 gang 450 mmfd. variable condenser
- 2 Coils (Allied Radio #60-590)
- 1 50 mmfd. mica condenser
- 4 Fahnestock clips
- 4 L Brackets
- 8 Wood screws
- 6 6/32-1/4" R.H. machine screws
- 1 Tuning knob
- 7 No. 6 soldering lugs
- 1 .004 mfd. mica condenser

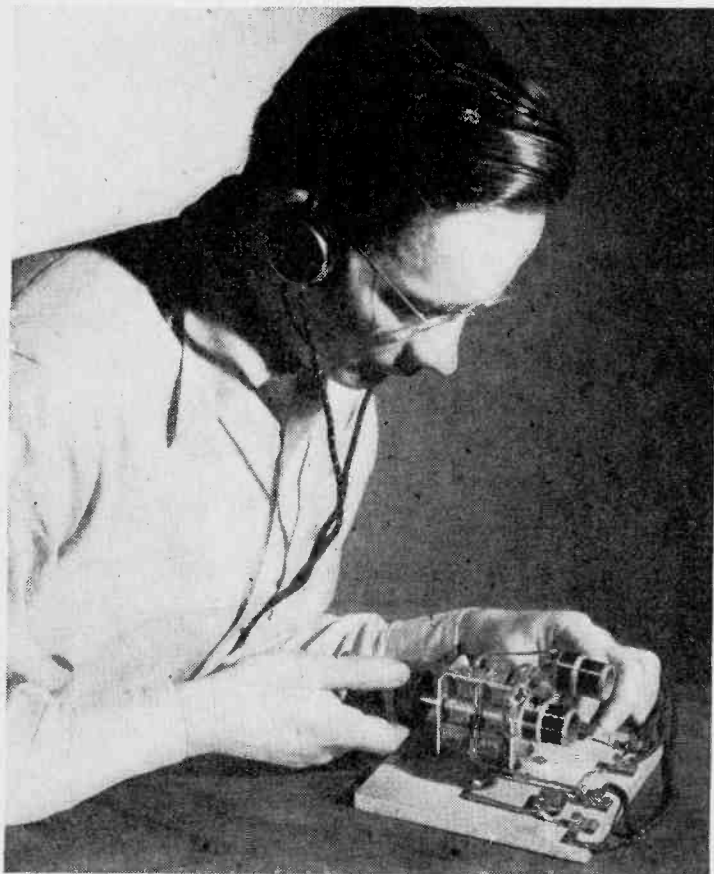

tions with better than average selectivity. This is accomplished by the use of two tuned circuits instead of the usual single tuned circuit used in most crystal sets. Like all crystal sets, this receiver requires no external power to operate it. It is simple to construct and operate, and is economical to build.

Of the two important special features of this set, one is the use of a 1N34 crystal diode. It provides for greater sensitivity, eliminates the need for adjustment, requires no special mount, and may be wired into the circuit directly. The crystal is protected from dust and dirt and is less subject to damage in use. Its small size makes it convenient to use. The same crystal, as in this set, was developed during the war for use in radar equipment as

ONE of the greatest shortcomings of the average crystal set in providing satisfactory broadcast reception, especially in metropolitan areas, is lack of sufficient selectivity to separate stations. The receiver described in this article is an offshoot of the old fashioned crystal set that has been popular for so many years. But it has now been brought up to date, especially with regard to selectivity.

This set is designed to cover the broadcast band and to produce good volume on local sta-

a detector. It is now available for general use and, while it is more expensive than the old crystal detector, it is worth the difference.

The variable selectivity incorporated in this crystal set is found in few other crystal sets. It is especially advantageous when the receiver is to be used in an area serviced by two or more local broadcast stations. With the set adjusted for maximum selectivity, the simultaneous reception of two or more local stations which is characteristic of the average crystal set, is greatly



# PRACTICAL RADIO INFORMATION

Including Frequency Modulation—Television, etc.

Inside Information for all Servicemen—Aircraft Pilots, Students.

772 PAGES, 400 DIAGRAMS

is complete—gives Authentic Principles & Practices in Construction, Operation, Service & Repairs. Covers clearly and concisely Radio fundamentals—Ohm's Law—Physics of sound as related to radio science—Measuring instruments—Power supply—Resistors—Inductors—Condensers—Transformers and examples—Broadcasting stations—Radio Telephony—Receivers—Diagrams—Construction—Control systems—Loudspeakers—Antennas—Auto. Radio—Phonograph pickups—Public Address Systems—Aircraft & Marine Radio—Radio Compass—Beacons—Automatic Radio Alarms—Short Wave—Coil Calculations—Testing—Cathode ray oscillographs—Static Elimination—Trouble Pointers—Underwriter's standards—Units & tables. REVIEW QUESTIONS—Ready Reference Index.

**\$4 COMPLETE • PAY \$1 A MO.**

To get this practical information in handy form—Fill in and

MAIL COUPON TODAY!

AUDEL Publishers; 49 West 23rd St., New York  
Mail AUDELS NEW RADIOMAN'S GUIDE for free examination. If O. K. I will send you \$1 in 7 days; then remit \$1 monthly until \$4 is paid. Otherwise I will return it.

Name \_\_\_\_\_

Address \_\_\_\_\_

Occupation \_\_\_\_\_

Employed by \_\_\_\_\_

RE



**BOYS!**  
**Make Your OWN RADIO!**  
Learn Interesting Details

Fun, interest and education in making your own simple, tubeless, batteryless crystal radio. Send 25c for a genuine Melomite crystal with complete illustrated instructions for making your own set. Compete with others for long distance reception. Crystal sent postpaid with instructions and our own publication "The Magic Crystal" which is full of news, diagrams, questions and answers of interest. Send 25c TODAY.

You may start a successful career in RADIO. Send 25c

ALLEN RADIO, Dept. 123, Clinton, Missouri

## RADIO MADE EASY! A JRI Home Trainer

A NEW APPROACH to radio repairing. Here is a SIMPLIFIED METHOD of repairing radios that can be LEARNED QUICKLY—Begin repairing immediately! A COMPLETE KIT OF ALIGNMENT TOOLS INCLUDED! Balance ANY RADIO with these tools. Prepare for a GOOD INCOME NOW! Send for the JRI Home Trainer TODAY and get Alignment Tool Kit—BOTH FOR ONLY \$9.75 postpaid, or plus c.o.d. charge. Pays for itself almost immediately!

**Satisfaction Guaranteed**

**THE JRI TRAINERS**

P. O. Box 2091

Dept. RE 49

Chicago 9, Ill.

minimized and in most instances it has been entirely eliminated.

Variable condenser tuning is used in preference to tapped coils or otherwise-variable inductances for greater ease of operation and compactness of construction.

In assembling the parts for this set, it is important to first determine the correct position of the variable condenser in relation to the base board. The condenser must be mounted so that when the plates are unmeshed the rotor plates do not hit the base board. The four holes on the bottom of the condenser, two front and two rear nearest the corners, are then tapped to take  $\frac{3}{32}$ - $\frac{1}{4}$  inch machine screws to mount the condenser brackets. Self-tapping metal screws may be used instead of tapping the condenser frame but in either instance care must be taken to prevent the ends of the screws from interfering with the movement of the rotor plates or from shorting rotor to stator, depending on the make of variable condenser used. Mount the coils in the manner described above, on the condenser frame using the two holes nearest the top rear corners. Screw fahnstock clips and soldering lugs to the base board of the set.

Before proceeding with the wiring, it is important to note that the end of the coil nearest the bracket is called the "cold" end, and is the bottom of the coils in the schematic diagram. Failure to note this point will result in reduced selectivity, you will find.

After the condenser mounting brackets and coils have been attached to the condenser, the coils should be wired into the circuit with the exception of the variable condenser ground connection and the connection to the series antenna condenser; however, the length of these leads should be approximated and soldered to the variable condenser. The 1N34 is now attached to the variable condenser. Attach the variable condenser and coil assembly to the base board and complete remainder of the wiring.

No special adjustments are required to place the set in operation. Connect antenna, ground, and phones to the proper clips. Selectivity is varied by moving the coupling coils (L-2 and L-4), selectivity increasing as the coils are moved down the tuned coils. It will also be found that as the coupling coils are moved up to decrease selectivity, volume is increased. In areas having few broadcast stations well separated in frequency, it will be found desirable to adjust for minimum selectivity and maximum volume although volume will still be satisfactory when the set is adjusted for maximum selectivity. Care should be exercised in adjusting coupling coils to prevent breaking the coil leads.

Tune slowly and carefully for maximum volume and re-adjust coupling coils for optimum volume and selectivity when necessary. Also necessary for proper operation are a good antenna and ground. An out-door antenna as high and long as conveniently possible should be used.

It is advisable to use high impedance headphones. Although low impedance phones will work they will usually decrease selectivity. Double headphones with a resistance of about 2,000 ohms are preferred. A set of headphones is the only accessory needed to operate the crystal set.

When circuit L1-C1 is tuned to the frequency of a station, current flows in the circuit and sets up a magnetic field which cuts the turns of coils L2, causing a current to flow in circuit L2-L4.

By inductive coupling, energy is transferred from L4 to the tuned circuit L3-C2 which is identical to and ganged with L1-C1. The radio frequency current is rectified by the 1N34 and its audio frequency component reproduced by the headphones. Greater selectivity is obtained by using two loosely-coupled tuned circuits. Capacitive coupling between antenna and detector circuit is minimized by grounding the "cold" end of each inductance.

## "Ocean Hopper" Receiver



Let's tune in on China with our completed "ocean hopper."

How to build a two-tube wonder that can pick up radio signals from the four corners of the earth

By LLOYD D. APT

Engineering Division,  
Allied Radio Corporation

**T**HERE have been many 2-tube receivers capable of long distance reception, but here is the latest in a well designed unit that will literally "hop the ocean" and pick up signals from the four corners of the earth when conditions are right.

Only two tubes are used but these are selected to give best possible performance. Complete wave length coverage of short wave bands from 9.5 meters to 200 meters and to broadcast bands from 200 to 550 meters (540 to 1600 kilocycles) is made possible in a simple manner by using plug-in coils. These coils are available already wound and eliminate the usual tedious job of winding your own coils with sometimes uncertain results. The chassis, too, can be obtained al-

ready punched and formed, eliminating what otherwise might have been the toughest part of building this receiver. The beam power output tubes will provide loud speaker performance on the louder local stations, but headphones are required to hear the weak DX stations.

Type 12J5 tube is used in a stable regenerative oscillator, grid leak type detector circuit. This type of circuit is still the best to use when you want highest possible sensitivity from one tube. Higher amplification would have been possible with a pentode type tube as a detector but they are very critical in adjustment and operation is often unstable.

The 12J5 type tube was selected as the best possible compromise for providing greatest stability as well as sensitivity. The type 117P7 double-function tube contains a beam

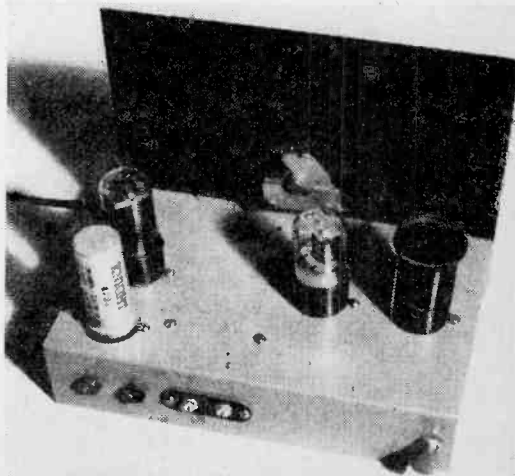

Top view of the back part of the receiver.

power amplifier and a 1/2-wave diode rectifier to provide "B" voltage. So you have the equivalent of three-tube operation from only two.

The tube heaters are connected in series and operate directly off the 105-125 volt line, either AC or DC. The tubes are operated slightly under rated filament voltage since the two tubes together call for 117 plus 12 or 129 volts; this does not affect performance and serves to simplify the circuit and give the tubes longer life. No ballast tube or line cord resistor is used, which means no waste of power.

There are three variable controls on the front panel. One is for the control of regeneration in the oscillator detector stage. It would be likened to a volume control on a regular home type receiver. The other is the main tuning condenser, and the third is the "bandsread" tuning condenser. Actual control is accomplished by manipulating two dials at one time.

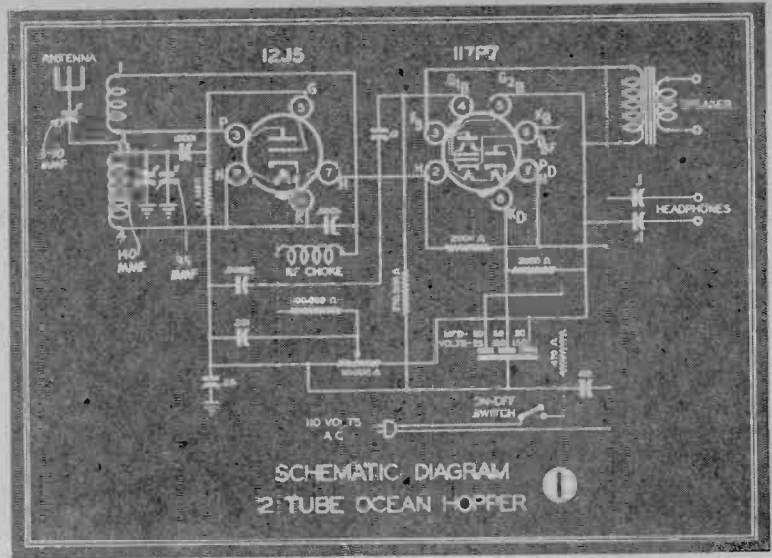

At first, you use the main tuning condenser and the regenerative control to select the station you want to listen to. Then you manipulate the hand-spread tuning condenser control and the regeneration control to bring the station in more easily and "on the nose". The power line "on-off" switch is on the regeneration control. Another control, not on the front panel, is a series

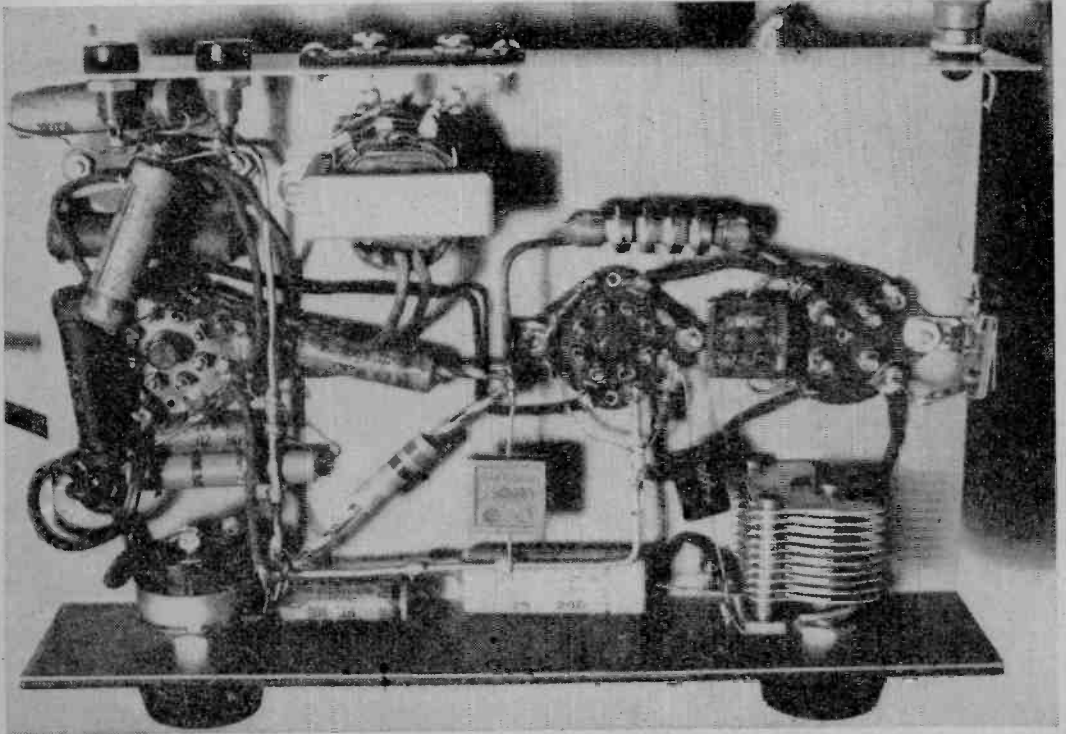

Underneath view of the receiver, showing completed connections and construction.



may be used to recheck wiring if you understand schematic symbols. It is a good idea to follow both diagrams and become familiar with the schematics as more advanced models of receivers and other electronic units are commonly presented in schematic form only.

The list of parts at the end of the article is complete in every detail. You begin by assembling all of the larger parts to the chassis before you start any wiring. These parts are easily identified from the pictorial diagram. The diagram is a bottom view, that is, with chassis turned upside down. Be sure the sockets are mounted with the tube guide slot pointing in the direction shown because this will result in shorter leads when the time comes to wire the receiver. The small fixed resistors and condensers are supported by their own pigtail leads at the time of wiring. Don't forget that the antenna and headphone binding posts must be insulated from the chassis with fibre washers.

The layout of parts provides short connections without any crowding of wires or parts. Note the heavy wire running from the negative terminal of the electrolytic condenser to the regeneration control and then to the 12J5 tube socket. This wire is used as a common ground and should be installed first, as many wires are connected to it. Wire slowly and carefully, checking off each connection on the diagram as it is installed. A few extra minutes spent in careful work and thorough checking will save a lot of time and trouble-shooting later. Keep your leads as short as possible and well separated from each other. Note the lead which goes through a grommited hole to the stator plates of the bandspread condenser. The bandspread condenser is located on top of the chassis, fastened to the front panel, and not shown in the diagram. It is not necessary to use the full length of the pigtail leads on the resistors and small condensers. Any excess leads should be clipped off and all connections made as short as possible on these particular parts.

Solder all connections using rosin core solder only. Avoid acid core solder or acid flux, as they form corrosion on copper and will give you trouble later. Pre-heat the parts to be soldered before applying the solder. By this we mean that you hold the soldering iron tip against the wire and terminal a few seconds first. Then apply just enough solder to cover the connections and fill the crevices between the wires. Remove the iron and solder, but do not move the wires until the solder has set. Don't use any more solder than is necessary to make a good bond. When more than one wire is to be connected at a particular point do not solder until all of them are installed to that point.

When you are through with the assembling and wiring it is a good idea to go over it once more, checking against both diagrams to be sure that there have been no omissions.

Use one of the broadcast coils to test the receiver the first time. Plug it into the four-

prong socket. Connect the aerial lead-in wire to the antenna binding post. No external ground is necessary as the power line serves as ground. Plug the radio into a 110-volt AC or DC power socket and turn the switch on. Wait a few seconds for the tubes to warm up. If DC is used, it is sometimes necessary to reverse the plug in the outlet to obtain the right polarity. If no dull red glow is seen at the top of the tubes, the filaments are wired incorrectly and the wiring should be rechecked carefully. Now follow these two steps:

1. Advance the regeneration control until a thud and a hiss are heard in the earphones. This is the critical point of oscillation.
2. Adjust the antenna trimmer for the maximum capacity possible while maintaining the critical oscillating point over the entire tuning dial.

The receiver is now adjusted for maximum sensitivity. For greater selectivity, set the trimmer at a lower capacity. Music and speech are best received with the regeneration control set just below the critical point of oscillation while code (C.W.) stations are received with the control just above this point.

Tune for a station with the main tuning dial, at the same time maintaining the highest point of sensitivity with the regeneration control. After the signal is heard, readjust the regeneration control for clearness. Greater separation of stations within a band will be obtained by using the bandspread condenser.

Short-wave tuning must be done very carefully as the signals occupy a small space on the dial. For best results at night tune around the 49 meter region. In the daytime tune around 25 meters. The antenna trimmer adjustment is quite critical on short wave. Adjust so that the set regenerates over the entire band of the coil used. You will become adept at this after you've had a little practice.

With a good high antenna, 75 to 100 feet long and properly installed, you'll find that this "Ocean Hopper" will really "bring them in."

## New Light-weight Radar

• A new light-weight search radar, now being perfected by the Army Air Forces, should prove quite a valuable addition to commercial and private plane equipment. Known by the army as APS-10, it is only 125 pounds in weight and is operated by five controls, as opposed to the 500-pound, 34 control radar employed by the army.

The new radar is designed to remove the hazard of flying in darkness or fog. With its cathode tube, 360 degree microwave screen, and reflections from objects in proportion to their position and degree of reflectivity, it gives accurate fluorescent pictures of terrain.

Scope can be made to trace any one of five ranges. The large-scale details of the 4 mile setting are best for close traffic flying, while the 90 mile range is for cross-country navigation.



# Tapped Coil Crystal Set

**T**HIS easily constructed crystal receiver which uses few parts, needs no power supply, has a minimum of adjustments, and will give clear reception over a limited area. It is designed to give maximum selectivity in metropolitan areas where several high-powered radio stations may be found. Where *selectivity* is not necessary, you can adjust this set to provide maximum *sensitivity* by placing extra taps on the secondary winding while constructing the coil, as we will explain later.

The receiver may be mounted on a board  $4\frac{1}{2}$  by 6 in. or it may be placed with the earphones in a cigar box for easy carrying. Before beginning construction, carefully examine both schematic and pictorial diagrams. It's wise for beginners to work with the pictorial diagram while doing the actual construction, as it shows positions and identities of each part, wire and connection. Then, as construction progresses, they should check



Want to try a receiver with fixed crystal detectors?  
Here is a selective circuit with few components

By MILO ADLER



The crystal set is shown above mounted in the cigar box with headphones in place beside it.

with the schematic in order to become familiar with the symbols used and to better understand the actual workings of the circuit and its operating principles. When you can follow more complex circuits, and the symbols, part functions, and wiring procedure are completely familiar, you only need the schematic as a guide.

First drill two holes for mounting the coil  $\frac{3}{8}$  in. from each end of the coil form and just large enough to pass the  $\frac{5}{16}$  in. machine screws used for mounting the coil. Next drill two holes shown at A in the pictorial diagram in the coil form, locating the first hole  $\frac{3}{8}$  in. from end of coil form as mentioned above and the second hole  $\frac{1}{8}$  in. from the first one. Then carefully unwind 5 to 10 ft. of No. 22 enameled wire, being sure not to kink it as a kink may cause it to break while coil is being wound.

Pass about 5 in. of wire through the second of the two small holes in the coil form from the outside of the coil form towards the inside. Next pass the same wire through the first of the holes from the inside of the coil form, and pull small loop on inside of form taut. Fasten coil of wire

to a stationary object or have someone hold it, being careful not to cause any sharp bend in the wire. Pull the wire taut and slowly rotate the coil form, thus winding the wire on the form. Wind 20 turns on the form for the primary winding. Stop every few turns and press the turns of wire together so that coil form cannot be seen between turns of wire. After 20 turns are wound on the coil, leave approximately 5 in. of excess wire and cut off the remaining portion.

Drill three small holes at point B (see pictorial diagram) and fasten end of primary winding through two of these holes in the same manner as the beginning of the coil winding, using two of the holes. Use the center and remaining hole at B to fasten beginning of secondary winding. Start the secondary winding as you did the primary, with a 5 in. lead coming from the coil, and place 30 turns on the coil form. Place the tap (T in diagram), at 30 turns from point B on the coil; this tap or loop is made by scraping the black enamel coating from the wire, twisting to form a small loop, and soldering the wire together.

Now place the remaining 80 turns of the 110-turn secondary on the coil form and fasten end of winding through two small holes (at C in diagram). If you want to be able to adjust the sensitivity and selectivity of this crystal

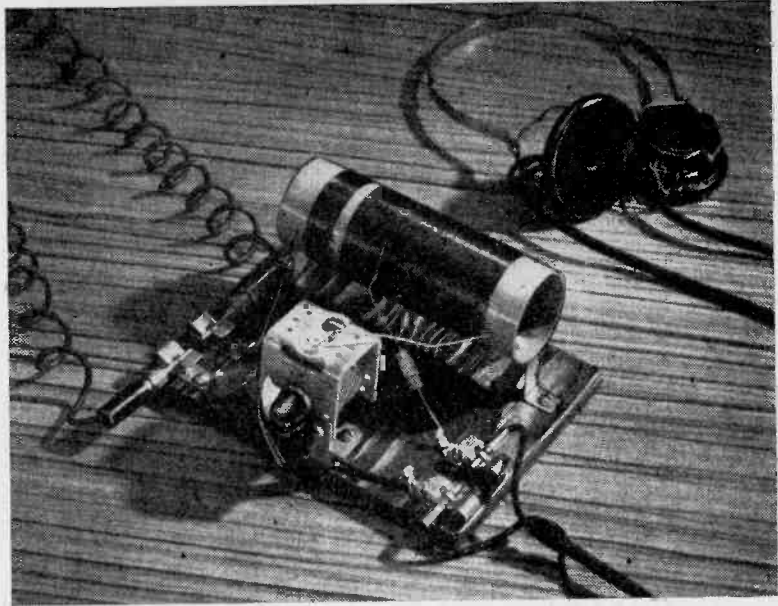

Completed "breadboard" version of crystal set with headphones connected.

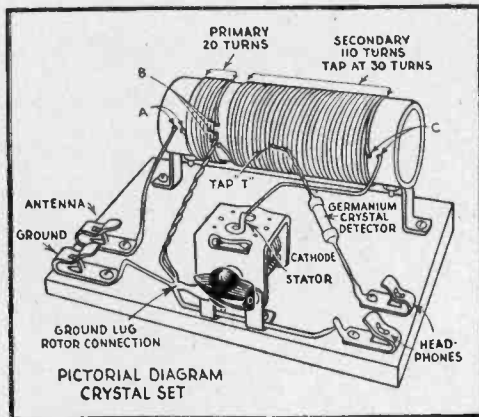

set, place taps every 10 to 15 turns while winding the secondary winding. But don't place any taps on the secondary before the first 30 turns.

Receiver construction will vary depending upon whether a "breadboard" or cigar-box model is to be constructed. The wiring of the receiver will be the same regardless of which model is constructed, so instructions for constructing the "breadboard" model will be

given first, followed by instructions for mounting parts in a cigar box.

For the "breadboard" model, first mount the coil mounting feet on the coil form, taking care not to damage the coil. Then mount coil as shown on the pictorial diagram. Next mount the variable (tuning) condenser with angle brackets; be sure to place a solder lug under condenser mounting screw, as shown in the pictorial diagram. Fasten clips to baseboard with wood or self-tapping metal screws.

If receiver is being constructed in a cigar box, after coil is completed cement coil in location shown in photo, using a quick drying radio or model builders' cement. Let cement dry thoroughly before doing any further work on the set. Then mount the variable condenser in the box with cement and two No. 6 by  $\frac{1}{4}$  in. wood or self-tapping sheet metal screws. Mount the

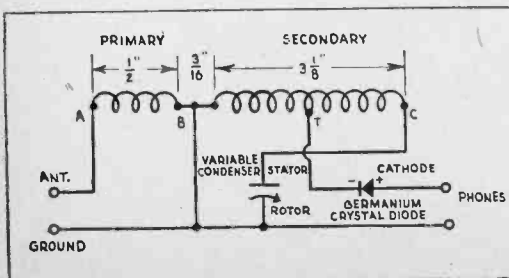

four clips for headphone, antenna and ground connections in the box with the same size screws that were used to mount the tuning condenser. Be sure to mount a soldering lug on the frame of the tuning condenser with a No. 6 by 1/8 in. machine screw.

Solder all connections, using rosin core solder only (acid-core solder and acid flux may cause corrosion). Pre-heat parts for easier, better work by holding soldering iron tip against wire and terminal to be joined for a few seconds. Then apply just enough solder to cover connection and fill crevices between wires. Remove iron, but do not move wires until solder has set—this takes only a few seconds. When more than one wire is to be connected at a particular point, don't solder and resolder. Install all wires

**MATERIALS LIST—CRYSTAL SET**

**Receiver Parts:**

- 1 1 1/2" x 5" coil form
- 55 feet No. 22 enamel wire
- 1 381.4 mmd. midget single gang condenser (Allied 61-009)
- 1 Germanium crystal diode (Sylvania type 1N34; Allied 7-219) or General Electric type 1N48 (Allied 7-250)
- 1 1 1/4" pointer knob
- 4 Fahnestock clips
- 1 4 1/2" x 6" x 3/8" plywood base or wood cigar box, depending upon model being made
- 8 No. 6 x 1/4" woodscrews
- 2 6-32 x 3/16" or longer machine screws
- 2 coil mounting brackets
- 2 condenser mounting brackets
- 1 solder lug

**Accessories:**

- 1 2000 ohm headset
- 1 antenna kit (Allied 83-100)

to that point before soldering. Work slowly, checking each connection as it is made. Mark the diagram with a colored pencil as each connection is completed. Be sure enamel coating on wire is scraped off before connecting ends of coil into set.

**Cure for Weak Stations**

To get the best results, use a good antenna, good ground, and a pair of high-resistance headphones (1000 ohms or higher). In most cases a long antenna is unnecessary. However, if stations are weak, or if nearest one is a great distance from you, you may need to secure an antenna at least 50 ft. long and as high as possible, and adjust set for maximum sensitivity by moving connection at point T over to point C (see diagram). Use glass or porcelain insulators at the antenna ends and rubber-covered wire for a lead-in to prevent contact with grounded objects.

If taps are made on secondary winding when coil is constructed, move connection to crystal diode up and down coil until a tap is found which gives the best performance for the station being received. For a ground, drive a few feet of metal rod or pipe into moist earth or make a connection to a cold water pipe or radiator.

The broadcasting station microphone converts sound to an auto frequency (AF) current which fluctuates as the sound changes in pitch and volume. This AF current is an electrical pattern of sounds picked up by the microphone. Since it cannot be transmitted alone it is combined with a strong, steady radio frequency (RF) current. The combination is sent out through an antenna, becoming radio waves. The RF signal is called the "carrier" because it "carries" the AF signal. Some of these waves will strike your receiver antenna, setting up a current which travels to the set. The crystal detector "demodulates" the signal—that is, it takes out the RF signal, but allows the AF to continue to the headphones where it is converted to sound. The coil and tuning condenser select a particular signal from the many constantly striking your antenna. Hence you adjust the condenser to "pick up" the station you want.

**Kit Available**

A complete kit for constructing the "breadboard" model of this receiver is available at a cost of less than \$3.00. This kit contains all materials necessary for constructing the "breadboard" model. The only extra components needed will be the cigar box when constructing this particular model. The cigar box used by the author was for Corina Larks cigars. It was sanded to remove the printing and then given two coats of shellac. The handle shown may be purchased from your local hardware store.

• If you want to secure the kit for constructing the "breadboard" model of this crystal set, write Allied Radio Corp., Dept. S, 833 W. Jackson Blvd., Chicago 7, Ill.

**Vacuum Cups Give Radio a Soft Ride**

- Radio amateurs and experimenters find that vacuum cups with a machine-screw molded in and a thumb-nut attached, make good rubber cushions and shock absorbers on a receiver or transmitter chassis. Sketch shows a gang-condenser held and cushioned on chassis, a sub-as-

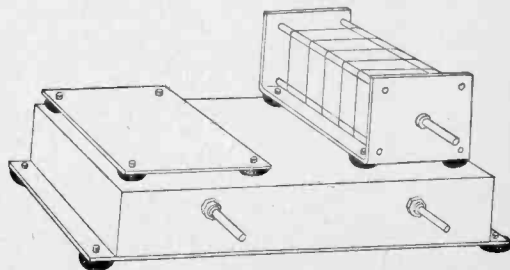

sembly panel cushioned and held to chassis, and chassis itself cushioned from operating table. In latter case, cups also keep chassis from sliding and scratching furniture. Cups are sold in most supply stores.—ARTHUR TRAUFFER.

# Replacing Filter Condensers

How to find and replace defective paper and electrolytic type condensers

By ADOLPH SUCHY

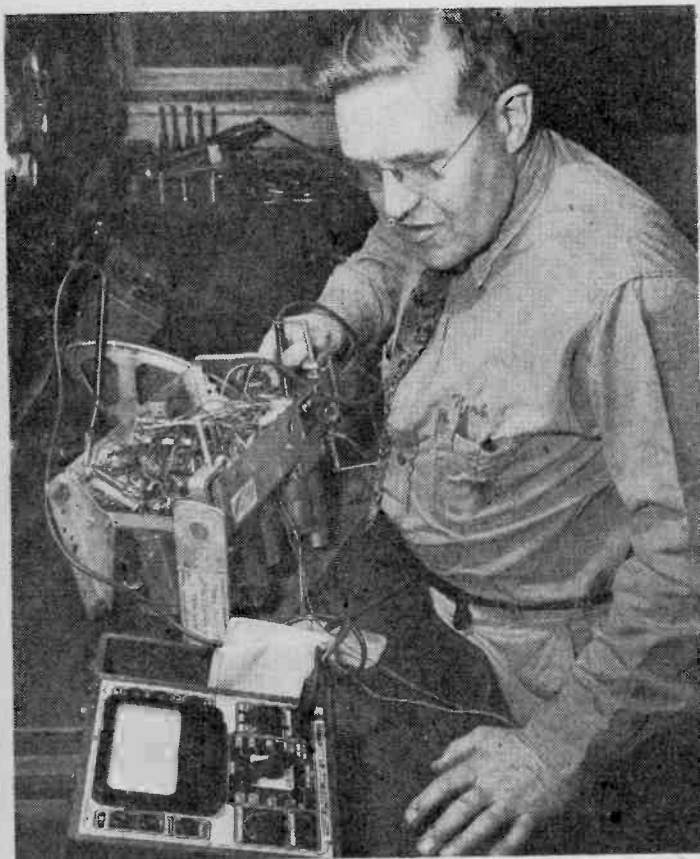

H. W. Lederhaus, radio service man from Jackson Heights, N. Y., testing condensers in a Philco radio. Meter pictured is a multi-meter used for continuity-testing, as Mr. Lederhaus is doing here. When continuity test indicates a short circuit, it means a defective filter condenser.

**T**HE filter condensers are defective. I'll have to take the set to the shop and replace them." This is one of the most common faults that the radio repair man finds as he inspects the millions of radio receivers that need his attention every year. After a set is allowed to stand unused for a period of time, electrolytic condensers dry out and cause trouble. It is advisable to have such sets thoroughly checked by a reliable radio repair man before using.

When a receiver becomes defective, a thorough check should be made of the tubes. If the rectifier tube is the one causing the difficulty a complete check of the filter system should be made

before replacing it with another tube. A short circuited filter condenser can blow out as many rectifier tubes as you can afford to buy. This is especially true in AC/DC receivers where the rectifier tube has a fuse incorporated within the tube itself for protection. When this fuse blows the tube must be replaced. In straight AC sets, heavy sparking or "fireworks" inside the rectifier almost certainly indicates a short-circuited input filter condenser. Another indication of this fault can be detected by turning the set on for a short period of time and seeing if the plates of the rectifier turn red. At the end of this article is a list of the rectifier tubes most frequently used. Consult the chart usually found in the back of your radio to see if your set contains one of these tubes. In the modern radio set electrolytic condensers are used for filtering. It is not uncommon that these should lose capacity or open circuit. An open circuited condenser may either make the set sound as if the announcer had a frog in his throat or there will be a high pitched whistle which will not tune with the set. An open filter condenser also causes low voltage in the remainder of the set.

On most receivers manufactured before 1934 paper condensers were used in the filter. The word "paper" does not refer to case in which condenser itself is packaged but

to dielectric substance used in condenser. A paper condenser consists of alternate layers of metal foil and treated paper. Thickness of treated paper determines "working voltage" of condenser. Each condenser is marked with the capacity and working voltage. The capacity is the ability to store electricity and the replacement condenser should be as near to the original in capacity as can be procured. Circuit design of filters is beyond the scope of this article. Suffice it to say that considerable engineering has gone into the calculations of the manufacturer in the original design of the circuit and this should be followed as closely as possible. Figure 1 shows

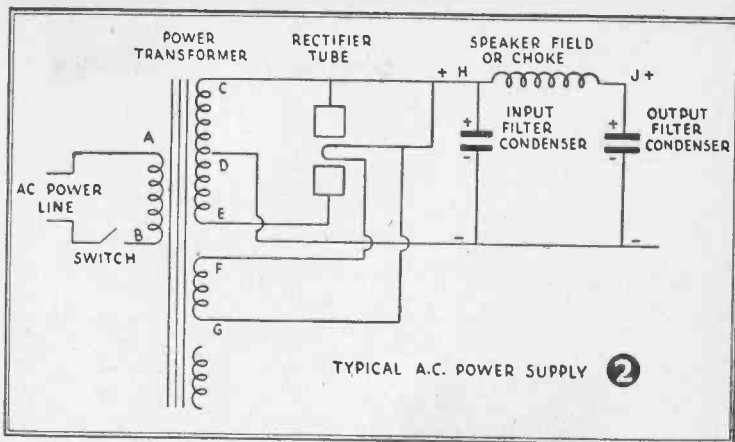

paper condenser used for replacement. When there are several of these condensers packed in one container or block and the common leads all come out to one terminal. Figure 2 shows a typical circuit of a power supply using paper condensers. This may be tested as follows:

**AC TESTS**

- A-B 110-117 volts AC
- C-D 250-450 volts AC
- C-E 500-900 volts AC
- F-G 5 volts AC

**WARNING!** Use insulated test prods and keep fingers away from terminals. This voltage can be LETHAL.

**DC TESTS**

- H-D 200-400 volts DC
- J-D 180-350 volts DC

**RESISTANCE TESTS (Made with current OFF)**

- A-B 5-10 ohms
- C-E 300-500 ohms
- H-D above 10,000 ohms

These tests are all made with a 1000 ohm per volt meter. The basic circuit in Fig. 2 is common to many radio sets using electrolytic condensers also. Figure 3 shows types of condensers used in modern receivers. Fig. 3a is the single electrolytic condenser and Fig. 3b is the block type of condenser. Practically all electrolytic condensers are polarized; that is, they have a negative and a positive terminal. The tubular type always has a marking stamped on the case either with the word "positive" or a plus sign. In many of the can types the can itself is fre-

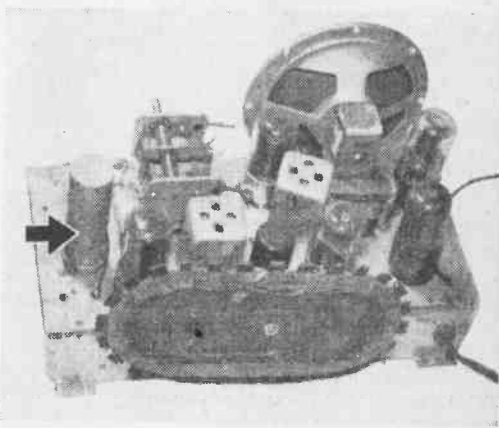

Top view of ac/dc chassis illustrating a frequently used can type of filter condenser.

quently the negative terminal. If only one terminal is visible at the bottom of the condenser then can is the negative. More recently condenser manufacturers have been bringing terminals out of condensers with leads. These leads are color-coded with positive colored red and negative, black.

Polarity of these condensers should be strictly observed, connecting positive terminal of the electrolytic to the positive leg of the circuit and the negative terminal to the negative leg.

On all AC receivers, use the highest voltage

Fig. 3A. Below, Mallory single tubular electrolytic condenser; near right, Sprague type PTM filter condenser; far right, Sprague type LS can type single electrolytic with can as negative terminal.

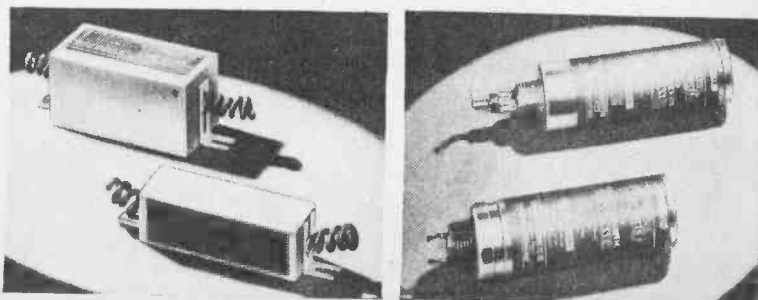





Fig. 3B. Typical condenser blocks of electrolytic type. (Left, Sprague type EL self-mounting can-type capacitors; right, Sprague type LM capacitor).

rating procurable in replacing condensers. It is permissible to use a condenser of a higher voltage rating providing that the capacity of the condenser is the same as the one replaced. However, do NOT use a condenser of a lower voltage rating than the original and do not use a condenser of lower capacity. For practically all AC receivers the voltage rating of 400 or 450 volts on a condenser is usually sufficient.

While the same theory of operation holds good for both AC and AC/DC receivers, the AC/DC receivers present some unique problems in the filter circuit. Because of the half wave rectification used in most AC/DC receivers the capacity of all the condensers in the filter must be considerably higher. Also, in normal operation, voltages encountered seldom go above 120 volts. Therefore, voltage ratings of filter condensers can be considerably lower in this type of circuit. In the average case where replacement of

will be discussed under special circuits.

In sets manufactured before 1937 the field was frequently connected across the recti-

these condensers is necessary a voltage of usual manu- as 150 volt but this is recommended Figure 4 average AC/ supply. While circuit is typical, many variations

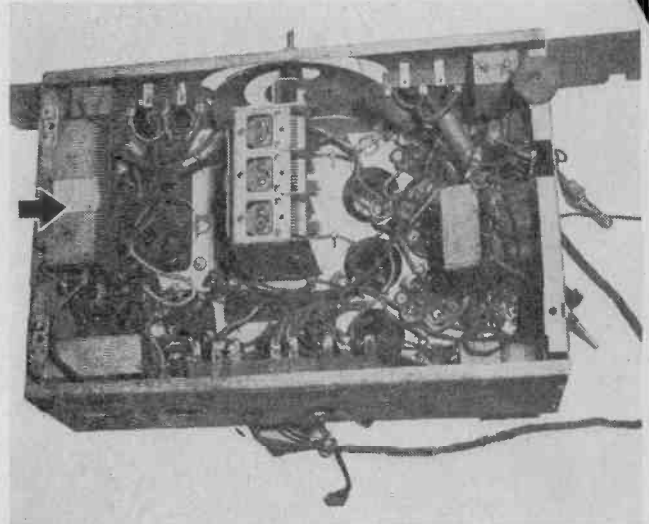

Bottom view of A.C. radio receiver showing cardboard cased filter condensers frequently used for replacement.

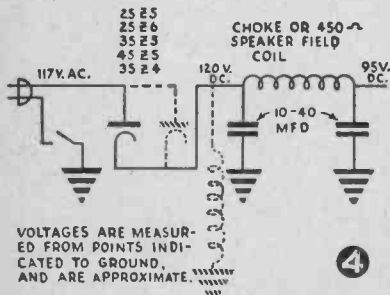

VOLTAGES ARE MEASURED FROM POINTS INDICATED TO GROUND, AND ARE APPROXIMATE.

Rectifier Tubes Most Commonly Used

In AC Sets	In AC/DC Sets
80	25Z5
5Y3	25Z6
5Y4	35Z4
5Z3	35Z5
5W4	45Z5
5T4	117Z6
5X4	
6Z4	

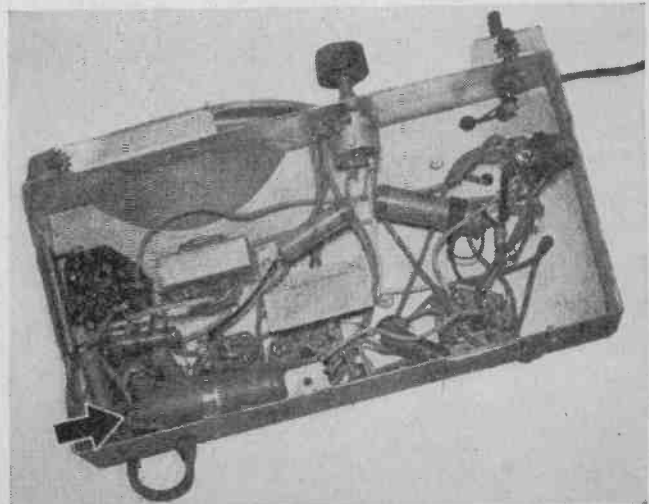

Bottom view of midget radio receiver showing tubular type filter condenser block on rear apron of chassis.

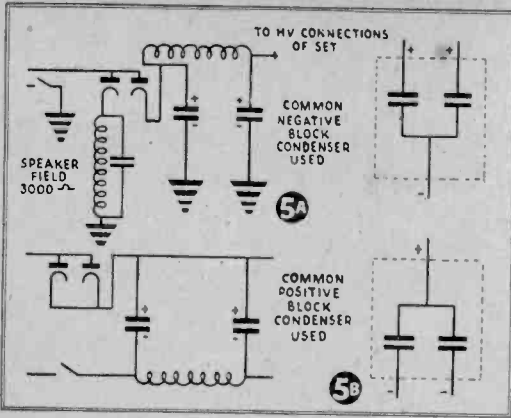

output. This field coil of the speaker had a resistance of 3000 ohms and is shown in dotted lines in the diagram. Since, the field coil has been used in place of the choke coil of the filter and usually has a resistance of 450 ohms. If one of the 3000 ohm fields are open the results will be low volume in the set and a rather high pitched tone quality. If a piece of iron or steel is placed near the pole piece of the speaker it will not be attracted to the pole piece. An ohmmeter can readily tell the story as to whether the speaker field is open or continuous. An open

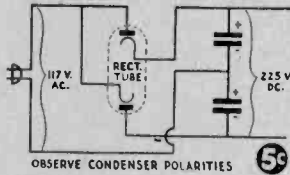

field of the 450 ohm variety will make the set inoperative causing no high voltage to go beyond the rectifier tube.

When replacing condensers it is wise to choose replacements which match the original as nearly as possible. However, it sometimes is necessary to replace a single condenser in a block and allow the rest of the block to remain in the set. In this case tubular condensers of the type illustrated in Fig. 3A are used. In any replacement it must be remembered that a sturdy mechanical job must be done if the replacement is expected to last for a long period of time. The leads should be insulated up to the point of connection and the condenser not allowed to "hang" in the set by its leads. A length of "spaghetti" slipped over the bare leads will more than pay for itself, for it may save a rectifier tube from blowing.

There are many variations and trick circuits that are used by manufacturers. Some of these variations are shown in Fig. 5. Fig. 5A shows a 3000 ohm field coil from a speaker connected to one cathode of a dual rectifier (25Z5, 25Z6) and the other cathode used to supply the high voltage for the set. Figure 5B shows a filter with the choke in the negative side of the line. In choosing a replacement for this type of set, a block condenser with a common positive should be bought. Figure 5C shows a voltage doubler. It doubles the voltage without the need for a transformer to step it up. The important consideration in this type of circuit is the polarity of the condensers. Be sure to connect them as marked.

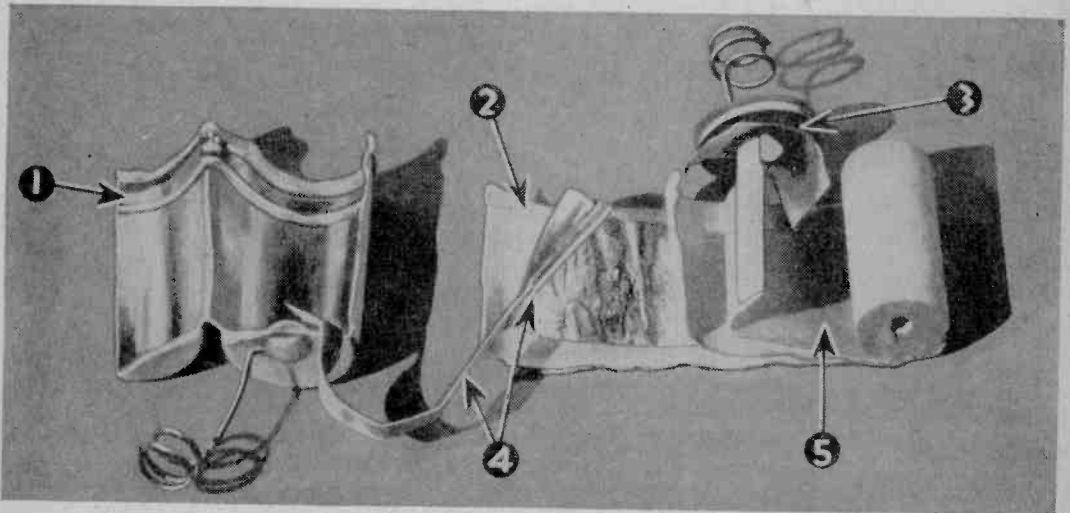

CUTAWAY VIEW OF "ATOM" UT-301 30 MFD 150 VOLT DRY ELECTROLYTIC

1. Aluminum casing.
2. Paper which has been saturated with electrolyte.
3. Contact to lead and anode foil has tar painted on the surface of the metal which serves to protect and seal the rivet connection.
4. Cathode foil and lead used to make contact with electrolyte held in paper.
5. Anode foil of etched aluminum. By etching the surface, approximately 10 times more foil surface is obtained, making possible greater capacity in a smaller volume.

# ELECTRONICS MADE EASY

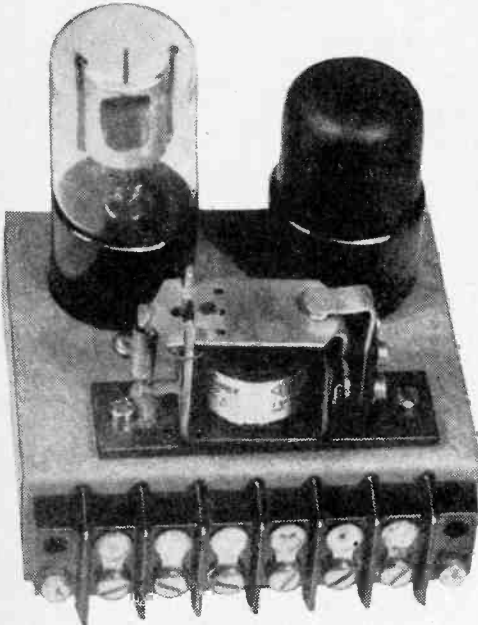

Front view of the electronic control. A photo-tube is shown in the 4-pin tube socket at left. At the right is the 1C21 relay tube. In the accompanying experiments, a cable replaces the photo tube.

Here is how to put electronics to work in your home, shop, or community.

By THOMAS A. BLANCHARD

Electronics Engineer

since radio graduated from the "cats whisker" stages. Nor shall we delve into the purely scientific whys and wherefores. Our aim here is to show you how you can put electronics to work in your home, shop, or local community. If we succeed in this, we will consider our job well done.

These electronic controls, as most of our readers have long since discovered, can be applied to a legion of tasks: opening and closing doors, controlling with velvet smoothness, the speed of motors; timing machine operations without the use of clockworks, counting and sorting parts, operate burglar alarms, detect flaws in rolled steel, etc. As this series progresses, you will learn how you can construct many of these controls from ordinary radio parts.

However, before we get on to building the electronic switch which appears in this install-

**A** DAY never passes that one does not read or hear of a new use to which electronics has been put to serve us all. Developments in this field have been coming so fast that most of us are left in an utter state of confusion by the varied types of applications found through the achievements of development engineers. These amazing pieces of apparatus arrive at such rapid rate that no one ever seems to find time to tell how they work.

That is what we propose to do. We will, of course, omit military applications. You want to know how you can use them. For the most part, electronic controls work on principles well known

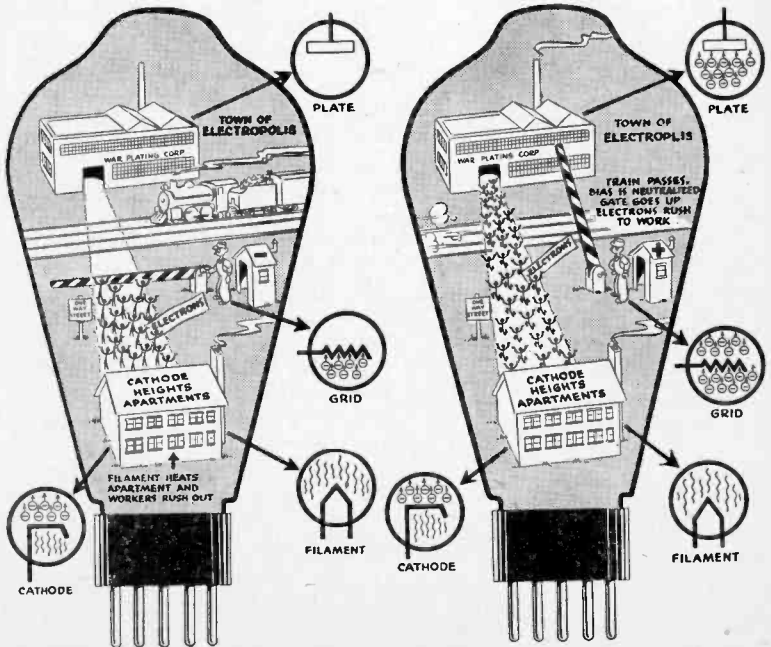

How Electronic Tubes Work.

ment, let's see if we can't break down whatever veil of mystery surrounds the phrase, *electronic control*. The heart of any electronic device is its tube (or tubes) which does one or two jobs: It can convert ordinary 60 cycle alternating current into pulsating D.C., or it can receive a weak impulse (signal) and magnify it to a considerable degree so as to operate some device that could not possibly function on the initial current delivered to it. In the first instance, the electronic tube functions as a rectifier. In the second, the tube serves as an amplifier.

The simplest way to understand the workings of an electronic tube is to think of it as a little world all of its own. Let's call the place *Electropolis*. Inside we have billions of little electrons ready to go to work the instant they are given the word, "go."

Ordinarily, these little creatures are penned up on the cathode element of the tube, but they want to get over to the anode element or plate, as it is more commonly known. However, they are held up by a third element, the grid. As long as you hold the gate down, these tiny nega-

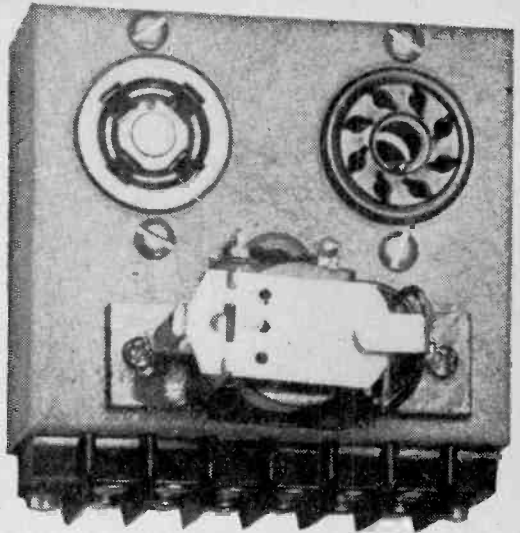

Looking down on electronic switch. In foreground is the 2,500 ohm relay. To the rear, left, the 4-pin tube socket, and to its right, the 8-pin socket.

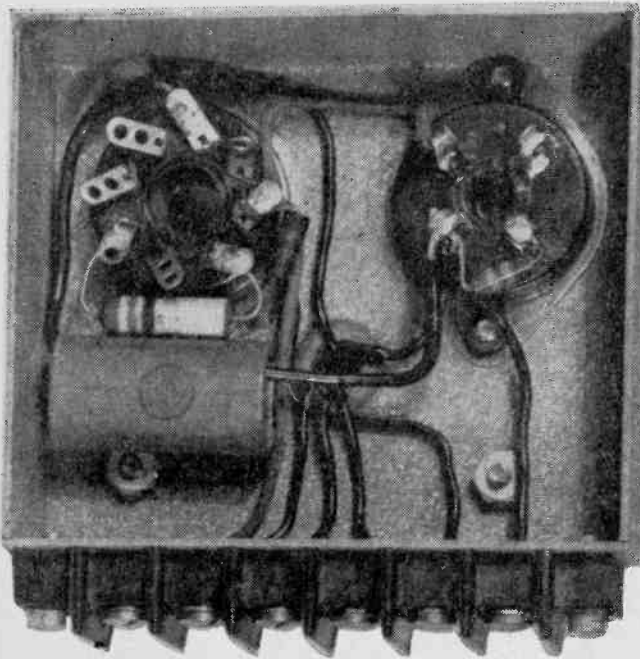

Bottom view of the electronic control. At left, the 8-prong socket for relay tube, and next to it, 4-prong socket for control plug. The 4 mfd. electrolytic condenser is below the 8-prong socket. Three fixed resistors forming the remaining parts are clearly visible.

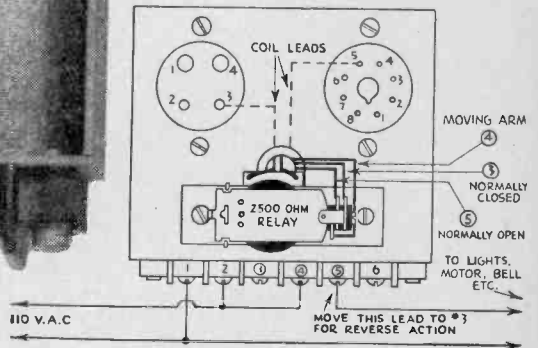
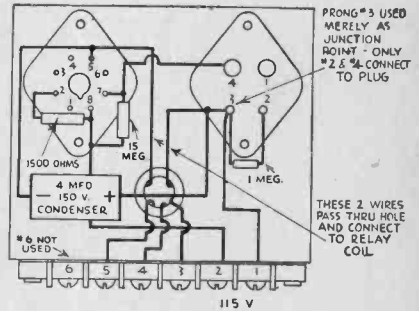

Layout of Electronic Switch.

tive charges cannot reach the plate, and no work is done. But the instant the gate is raised (the grid made less negative), the little people of Electropolis rush off to do their job. In the case of a rectifier, there is nothing to halt the flow of electrons from the cathode to plate once they are activated through heating of the filament.

This heat is conveyed to the cathode which causes the negative electrons to bounce off to the positively charged plate. Electropolis is strictly a "one-way world." Its citizens always travel from cathode to plate whether the tube is an amplifier or rectifier.

The secret of a good many electronic controls is in putting the grid element to work. The

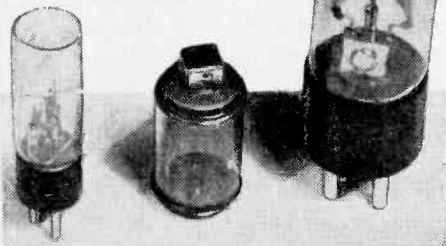
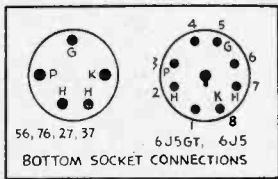
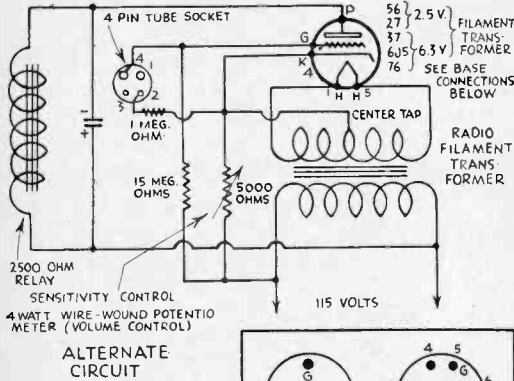
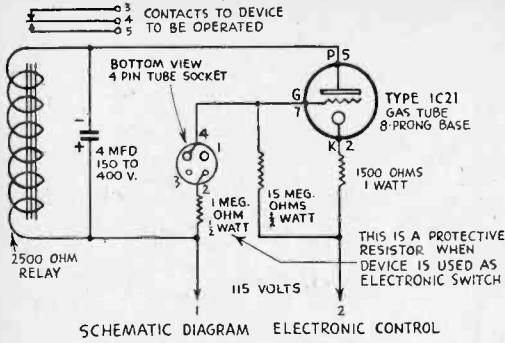

Photo tubes fall into two general classifications: gas and vacuum. The gas types are more sensitive to small quantities of light than vacuum types. Vacuum tubes, however, respond faster and are desired for certain applications. Conventional photo electric controls use gas type tubes. The most popular sizes of photo tubes are shown here. They are available in vacuum or gas.

grid, remember, acts like a gate. By applying a small amount of negative current to it, the grid produces a field that is sufficient barrier to keep the electrons from traveling from the cathode to the plate. Now in the case of a photo-electric control, the instant we focus a beam of light on the photocell, or photo tube, our photo tube becomes a conductor and allows a signal voltage to reach the grid and neutralize it. At that instant, electrons in the amplifier tube are released. They rush from cathode to plate and on to the relay. Current through the relay causes it to become energized. It closes or opens a pair of contacts which start or stop lights, motors, and so on.

The action of the electrons is like a dog chasing his own tail. Until such time as light is taken off the photo tube, they will race in and out of the tube going from cathode to plate,

LIST OF PARTS FOR ELECTRONIC SWITCH

- 1—Metal chassis, 3 1/2 x 3 1/4 x 1 1/4 formed from No. 18 black, galvanized, or other finished steel. Chassis of original control was gray crackle enameled.
- 1—1500 ohm metalized or carbon resistor, 1 watt size
- 1—15 megohm metalized or carbon resistor, 1/2 watt size
- 1—1 megohm metalized or carbon resistor, 1/2 watt size
- 1—4-pin tube socket (wafer or moulded bakelite type)
- 1—8-pin tube socket (wafer or moulded bakelite type)
- 1—6-post terminal strip (moulded or laminated type)
- 1—4 mfd. electrolytic condenser (rated 50 to 400 volts). (If relay should chatter use 8 mfd.)
- 1—2500 ohm D.C. relay, single pole-double throw. (2000 to 3000 ohm relay will also serve.)
- 8—6-32 machine screws
- 8—6-32 hex nuts
- Wire, rubber grommet, and solder.

NOTE—While actual values of parts should not be altered, the constructor may change the shape of the chassis, and so on to fit materials on hand.

through the relay to ground, then back to the cathode, repeating the cycle indefinitely.

A unique attribute of the electronic tube is that it will handle comparatively large amounts of current, opening and closing the circuit as if a mechanical switch were used. The control is achieved, without moving parts, from a tiny signal voltage so small that very sensitive meters would be required to measure it.

There is no better way to understand how electronic devices work than to see the actual results with your own eyes. And to accomplish this, we can easily assemble an electronic switch. Although simple to construct, it is by no means a toy for it may be applied to numerous industrial control problems.

The electronic switch is a practical example of the theory given in previous paragraphs. With signal voltages so small that their current cannot be felt but sufficient—even when passed through very high resistance—to neutralize the grid, we can control lights, magnets, motors, and so on, without making an actual electrical connection. As an illustration, note the photo in which the girl is controlling a buzzer and lamp simply by holding the bare ends of the control leads in her fingers. It can be understood that if body conductivity is sufficient to operate the electronic switch, it will then function by contact with liquids, mere moisture, and delicate metallic contact. Thus by flea-power energy on the initiating circuit, we can get trigger action to start



loads up to 10 amperes across the relay contacts. If greater loads are to be carried, the relay can be connected to a magnetic switch or similar device intended to stop and start very large loads.

The electronic switch is constructed on a simple metal chassis which, when bent to shape, measures only  $3\frac{1}{2}$ " x  $3\frac{1}{4}$ " x  $1\frac{1}{4}$ ". As indicated in the accompanying sketches, the chassis is provided with two  $1\frac{1}{8}$ " holes for a 4- and 8-prong tube socket respectively. A slot, or holes, located in the front of the chassis allows for installation of a 6-post terminal strip. While only five posts are used for the electronic switch, the extra terminal will be used in a subsequent control.

In the front center of the chassis, mount a D.C. relay having a coil resistance of 2,500 ohms. If this particular size cannot be obtained, any resistance between 2,000 and 3,000 ohms will be satisfactory. A  $\frac{3}{8}$ " hole is drilled in the chassis, just behind the relay, and fitted with a rubber grommet. Through it, coil and contact leads from the relay are passed.

After sockets and terminal strip have been mounted, the electronic switch is ready for wiring. The only other components, in addition to those already mentioned, are a 4 mfd. electrolytic condenser (one rated as low as 50 volts will do); a  $\frac{1}{2}$  watt, 1 megohm;  $\frac{1}{2}$  watt, 15 megohm; and 1 watt, 1,500 ohm resistors. Since space is not at a premium, all resistors can be of the 1 watt size if more easily obtainable.

The control can be wired up from this point in about half an hour. The reader can follow either the pictorial or schematic diagrams. To the uninitiated, the pictorial diagram may be the easier to understand, but paradoxically, the schematic symbols should be learned as diagrams drawn in this form are much easier to follow, espe-

The electronic control, with photo tube inserted in 4-prong socket, becomes an "electric eye." No mechanical or electrical changes are required to convert the device from a light control to an electronic switch.



Here light and buzzer are operated by body conductance. Merely holding the control leads loosely in the fingers is sufficient to cause the electronic control to function. In fact, by observing proper polarity when connecting the control to the 110 v. supply, lights can be turned on or off by touching only the grid (green) lead of the plug connector.

Experimental set up demonstrating the operation of this electronic control for regulating liquid levels. The black (grounded) lead, at the side of the jar, permanently contacts the liquid. When the metal electrode held by the operator is brought in contact with the liquid, the bell and buzzer produce an immediate signal.



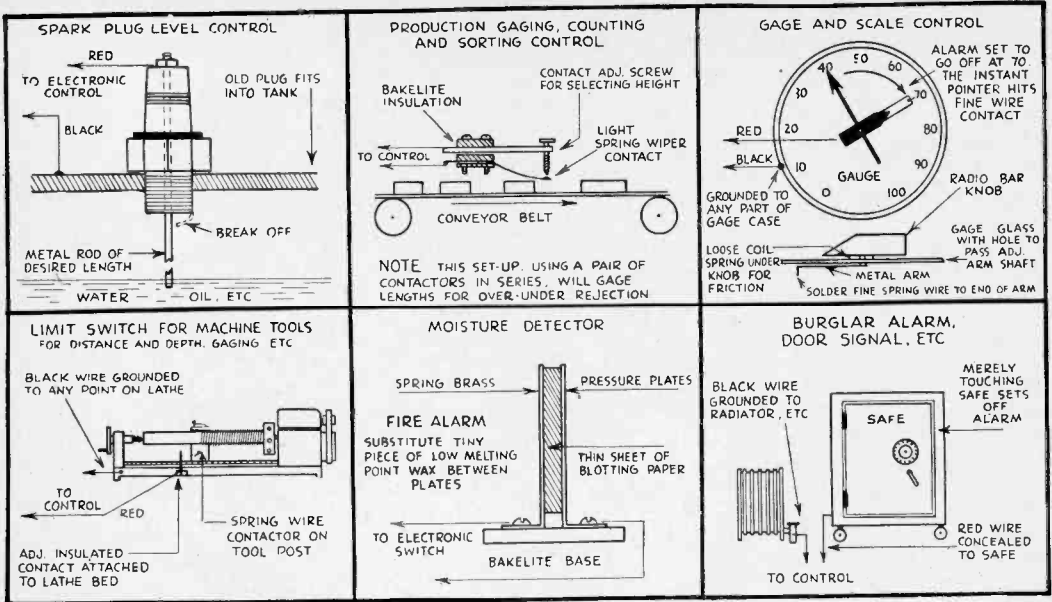

Some of the applications for electronic switch control.

cially when circuits are complex.

Terminals No. 1 and No. 2 on the terminal strip provide connection to the 110 v. supply. Terminal No. 1 connects to one side of the relay coil, the positive side of the electrolytic condenser, and to one end of the 1 megohm protective resistor. To anchor these leads rigidly, we use pin No. 3 on the 4-prong socket as a junction. Prong No. 3 is "dead" as far as our control is concerned. To complete the wiring on this portion of the circuit you need only connect the remaining relay coil lead to prong No. 5 on the 8-pin socket. Connect the negative end of the electrolytic condenser to No. 5 also. The free end of the 1 megohm resistor is then soldered to No. 2 prong of the 4-pin socket.

Terminal No. 2 on the strip connects to one side of the 1,500 ohm cathode resistor and one side of the 15 megohm grid bias resistor. The free end of the cathode resistor is then soldered to prong No. 2 of the 8-pin socket while the free end of the 15 megohm resistor is affixed to prong No. 7 of the 8-pin socket. Finally, a lead is connected this same No. 7 prong to the No. 4 prong of the 4-pin socket.

The only remaining operation is to connect the

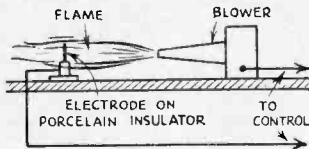

A flame conductor.

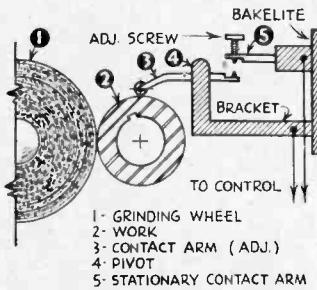

Another application of an electronic switch control.

contacts of the relay to the respective posts on the terminal strip. The moving arm contact is connected to No. 3, the contact against which it rests is connected to No. 3, and the normally open contact is connected to post No. 5. This done, the electronic switch is completed!

This finished control is really two controls in one. Our reason for using a 4-pin socket as a connector for the controller leads is that by simply removing the connector plug and inserting a 4-pin phototube, it becomes a remarkably sensitive "electric eye" control. More about this later.

To try out the control, insert a 1C21 tube in the 8-pin socket. A 4-pin tube base is obtained, and into pin No. 2 solder a black wire, and into the No. 4 pin, a green wire. The tube base is plugged into the socket, connections made to the terminal strip, and the control is now ready to be tried out.

The instant the two control leads are touched, the relay operates lights, buzzers, or any other device connected to it. By attaching the black lead to the side of a metal container filled with water, oil, and so on, and then connecting the green lead to a metal rod, the electronic switch will operate the instant the rod strikes the liquid. This little stunt demonstrates the possibilities of the electronic switch as a "floatless" liquid level control. Heretofore, to regulate the amount of water, oil, and so on, pumped into storage tanks and standpipes, cumbersome mechanical leverage-float systems were required within the tank to start and stop pump motors. As you have now witnessed with your own eyes, such con-

trol can be achieved without any moving parts! In the accompanying illustrations, there is a panel showing some of the applications for electronic switch control.

One of the most interesting applications for the electronic switch is a flame conductor. The carbon in any type of flame is sufficient to work the control. Using an electrode similar to the spark plug unit shown for indicating liquid levels, the control will ring a bell, shut off fuel pumps, and so on, if the flame goes out.

Those familiar with radio circuits have probably noticed that the 1C21 tube employed in the electronic switch does not employ the usual filament. The 1C21 is a rather recent tube designed for relay applications. Unlike the conventional vacuum tube, it is a cold cathode gas type. Earlier, it was explained that the electrons were bounced off the cathode through the heating of the filament. With this particular tube (and other gas tubes) electrons are released by a high potential gradient at the surface of the cathode, due to a difference in voltage between it and the anode or plate element.

Since we are in the midst of a war, it may not be possible for those without priority ratings to obtain a 1C21 tube. An alternate circuit providing equal results can be followed in which the conventional radio tube (a triode) is employed. In the alternate schematic you will note a filament transformer is used. This transformer will

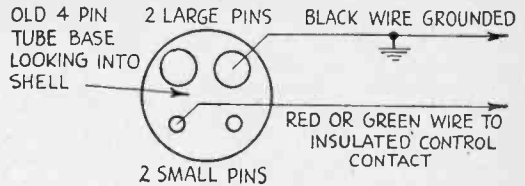

CONNECTING PLUG FOR ACTUATOR CONTACTS

NOTE—Black lead can be grounded to nearest point on device being controlled. If sensitive lead (red or green) must be carried any distance, it may be necessary to use a piece of auto ignition wire to protect it from capacitive effects. By observing proper polarity when attaching electronic switch to 110 v. line, it is possible to work control by body capacity alone. Thus a person touching only the red or green wire sounds the alarm.

have either a 2.5 v. or 6.3 v. secondary winding depending upon the type of tube used. You have a choice of five or more types of tubes that will serve well: Nos. '27, '37, '56, '76 or 6J5 are the most easily obtainable.

The alternate circuit is practically identical to the original except for the transformer and substitution of a variable instead of fixed resistance in the cathode lead. Since characteristics of each tube may differ slightly, the variable resistance in the cathode will compensate for this and provide a very desirable means of getting maximum sensitivity when the switch is eventually used as a photo-electric control.

## Radio Control for Models

**T**HE age of radio control for models is here! No longer is it necessary to have great skill or to make large expenditures to bring your model plane, automobile, boat or even your model railroad under the guidance of the fast and invisible Hertzian waves.

Those who have not yet seen radio controlled models in operation cannot well imagine the supreme thrill that comes with remote control. The little skyship loops, dips, rolls or dives at the touch of the button and the gas-operated model power boat swerves to the right or left or takes the gun as though a dwarf pilot were at the wheel. This is very easy to do and far less expensive than it was a few years ago. The mass production of radio equipment during the war not only reduced the postwar cost of relays, tubes and the like, but it also placed

Remote control by radio can be applied to model airplanes, boats or cars. An expert on radio control tells how it's done

By BORDEN W. CLARE

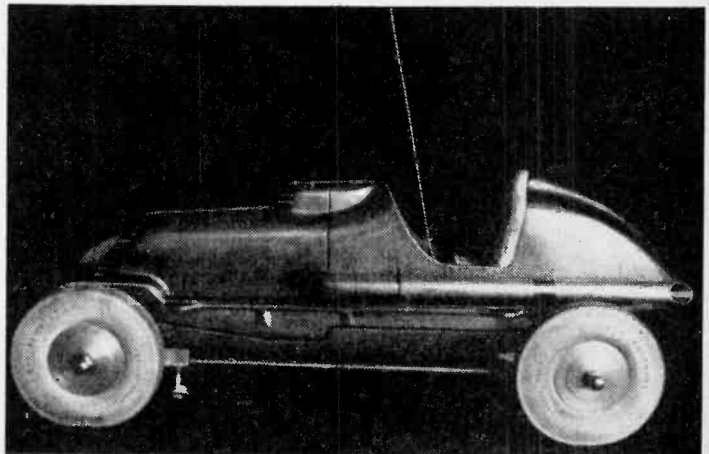

Cars such as this may be easily brought under radio control.

a tremendous quantity of radio surplus on the market, much of it of great use to radio control.

First the writer would like to say a word or two to the timid fellow who might think that the whole matter is far too complicated for him. The truth is that anyone who can read a radio diagram can assemble a radio control. Both the transmitter and receiver circuit are very simple and, should one assemble such an outfit to find that it did not work, the local radio repairman or the local licensed radio amateur is always there to help you get the bugs out.

When the radio impulse from the transmitter reaches the receiver carried by the model, amplification takes place and a sensitive relay is closed. The object of the relay is that of closing a local circuit on the plane for the release of purely local energy stored in the form of a spring, twisted rubber bands or a small battery used to produce mechanical motion through the medium of a motor or an electromagnet. It is this energy that is used to operate rudders, advance spark, etc. That is principle No. 1 of radio control. Keep it in mind.

Principle No. 2 relates to the control of the released energy itself. For instance, when the operator at the controlling transmitter sends forth a radio wave impulse, how does he know what function is to be produced on the plane or boat and how can he control that function? Is the boat or plane rudder going to turn left or right and how can the ground manipulator make it turn left or right?

The various results are brought about by means of a sequence selector mechanism usually operated electromagnetically. In a certain sense, we might compare such a system to a clock works. In a clock works, the gear system is under tension by means of a spring or weight and this represents stored energy which leaks away to drive the hands, being released gradually by the escapement wheel and verge. In a radio control system, the incoming impulse is amplified, passed on to a relay which closes a local circuit and permits an electromagnetically-operated ratchet to lift. This in turn allows a ratchet wheel to advance one notch.

This may have associated with it a moving or revolving contact switch, one contact on the switch and a corresponding notch in the ratchet wheel representing a certain single function of the boat, plane or car. Thus a plane, boat or car may be put through predetermined functions, but only on a sequence basis unless a greatly complicated and expensive two-transmitter system is installed. What we seek in this series of articles is a simple, inexpensive radio control system, even though it has the slight disadvan-

tage of requiring the operator to pass through unwanted selector points before a certain specific operation can be brought into play.

One example of an escapement of a selector mechanism is illustrated in Fig. 1. Here the electromagnet, excited by an impulse of local energy released by the sensitive relay connected to the output of the radio receiver, permits only a single notch or point on the escapement wheel to pass and this will represent a certain function of the model under control. Many different designs for such mechanism have been devised.

Typical of such functions on a gas operated model is a solenoid operated throttle illustrated in one form in Fig. 2. The escapement wheel of this selector unit is usually under tension produced by a few rubber bands. So much for some of the basic mechanical features of remote radio control. The radio principles will have to

be understood in some measure.

At the outset it should be pointed out that very low power is radiated by the short wave transmitters used in radio control and it behooves the operator to conserve every possible fraction of a microwatt of energy both in the receiver and in the transmitter. In the latter this calls not only for an efficient transmitter design and good in-

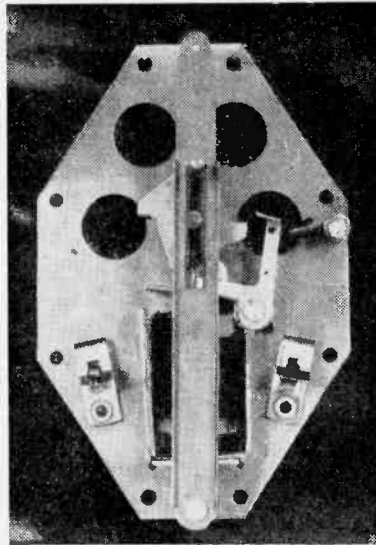

A light weight selector system used on a model plane. It is made mostly of aluminum.

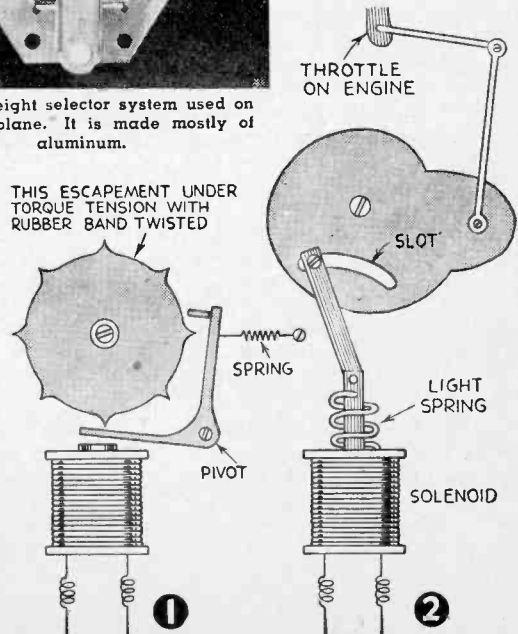



Walter Good, of Kalamazoo, Michigan, with the radio controlled plane and radio transmitter designed by him and his brother.

sulation but also for an efficient radiating system or antenna.

This means, for one thing, that the antenna must be tuned to the wave length or frequency in use. The second consideration is that some radiating systems display a directional effect in the propagation of waves. In the case of a plane in the air, complete reliable control might be lost by reduction of signal strength when the plane entered the weak zone of the wave field.

What the builder seeks is a radiating system that will produce a strong signal in all directions. It must be remembered at all times that the plane or boat receiver will pick up only a few millionths of the energy radiated by the con-

trol transmitter. Even operating over a short distance of several hundred yards, as most of these systems do, little energy is picked up by the receiver.

Experimenters in this field have discovered that if the transmitter has an antenna mounted horizontally, then the receiver should also have such an antenna. It is also to be pointed out that in case of the transmitter antenna its physical length should bear some definite mathematical relationship to the wavelength it is called upon to radiate. Model planes carry horizontal receiving antenna best because such affairs are better accommodated by the wing contraction of a plane, and this type of radiator is most used by the experts in the field.

It should be borne in mind that all transmission in this radio control field is carried on with UHF or ultra high frequency, which is just another way of saying very short waves. Therefore the best operation is at ten meters or less. In the case of an antenna intended for 5 meter band operation, a vertical antenna 8 feet high would be required. Such antennae are usually made on the telescopic principle, of brass tubing, so that wavelength adjustment may be conveniently made. Some operators prefer antennae only  $\frac{1}{4}$  of a wavelength long. In such a case the antenna is grounded and connected to the tuning inductance in the manner illustrated; that is, with a variable condenser used for the purpose of adjusting load and to prevent high voltage on the antenna.

With this  $\frac{1}{4}$ -wave system it is important that the connection between the inductance and the antenna be located on the antenna at a certain rather critical point usually found by means of some experimentation and usually about 15 per cent of the length of the antenna off the ground.

With the half-wave system shown in Fig. 4, no ground connection of this sort is made and the output of the transmitter is simply connected to the base of the antenna. The details of a horizontal radiating system are seen in Fig. 5. Here the antenna is simply a wire stretched between two insulators and connected to the transmitter by means of a feeder wire, the length of which is not particularly important. It must be remembered that such horizontal antenna have pronounced directional effects, although this may not be too important over short distances where model planes do not cover areas over one-half square mile. In the case of the horizontal antenna shown in Fig. 5, it is important that the feeder wire be connected at a certain definite distance from the end of the antenna proper, about 15 per cent, as in the former case of the vertical antenna.

There is still another efficient horizontal antenna system shown in Fig. 6. This is called the Delta Match antenna, apparently because of the triangle formed at the point where the feeder joins the system proper. Such systems are usually preferred by the experts when what is known as a push-pull output stage is employed

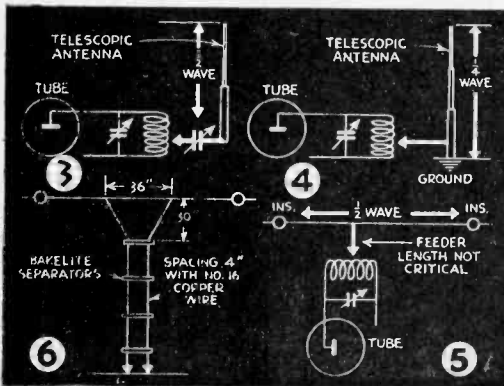



in a transmitter. In rigs of this sort, the feeder wires must be kept separated at a definite distance and insulating separators are used for this purpose. It is also best to employ a wire of a definite size. The separators may be formed of sheet bakelite cut in strips and drilled out at each end so as to pass the feeder wires.

The arrangement shown in Fig. 6 is set up for operation with a  $\frac{1}{2}$ -wave system. In reality, of course, these so-called  $\frac{1}{2}$ -wave systems do not operate on this precise figure but rather on a trifle less. The reason for this is perhaps the numerous X factors. These may be the type of feed system and its high frequency characteristics, the height of the antenna system above ground, the proximity of large masses of metal or large amounts of green foliage, etc. The vertical type of antenna is on the whole much more apt to respond best to theoretical length than the horizontal types.

While advanced amateurs may be able to calculate effectively on problems of this nature, the practical fellow for whom this series of articles is primarily written will wish to have some fast and reasonably accurate way of telling whether or not he is radiating all the energy that his small transmitter might be expected to yield. This may be easily done both by the aid of a meter in his transmitter circuit and also by the aid of a meter in the receiver circuit.

A milliammeter is placed in the plate circuit of the receiver and the transmitter of the control system is operated at six or seven hundred feet away. In the case of using the RK62 tube, the highest efficiency or maximum energy reception will be indicated by the lowest receiver plate current. Antenna adjustments at the transmitter will cause variation in the reading of the meter in the plate circuit of the tube.

In any event, continued success with radio control where VHF is used calls for constant vigilance on the part of operators because such transmitters do not "stay put" for long. Hence the boys who enjoy good radio control with more or less uniform operation are those who carefully check their transmitters and receivers before each flight. Even a change in weather may be important.

In the case of transmitter adjustment with vertical antenna, the operator may watch a plate current meter as he or his assistant makes adjustments in the length or period of the antenna. The highest plate current reading here indicates the amount of energy being radiated.

One of the principal problems of radio control for models is that of capturing enough energy from the transmitter so that it may be amplified and used to operate a relay carried in the model, the relay releasing local energy from batteries, twisted rubber bands or spring motors. If we were not dealing with models there would be no problem at all but the model imposes certain restrictions both in the size and the weight of radio receiving equipment that may be carried.

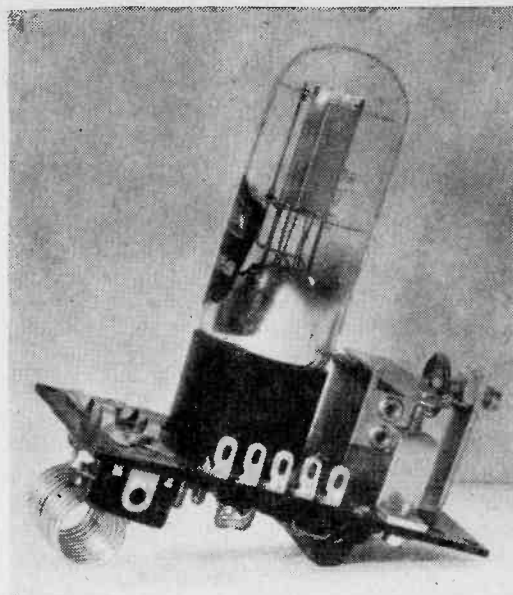

A fly-weight radio receiver intended for model airplane use. Frequency of this unit is 60 megacycles.

This is especially true of model airplanes. Then, too, models, because of their size, impose certain restrictions in antennae design and size. We must therefore take great care not only in the choice of the receivers carried by the model but it must also be constructed or assembled with the most approved materials. Those who are not accustomed to such work may well seek the assistance of a licensed radio amateur in the neighborhood. The chances are that he will be ready and indeed happy to assist and that more often than not he is a pretty bright fellow.

In the present article we will treat only the receiver itself up to the relay. Subsequent articles will deal with the design, operation and construction of the selective mechanism used to translate radio impulses into actual model functions.

The receiver herein described is a simplified regenerative outfit making use of the RK62 tube which is really a diminutive thyratron manufactured by the Raytheon Co. and sold under the aforementioned code number. Such tubes provide a very high degree of transconductance resulting in a very great increase in plate current or output when a radio impulse is received. When employed with a special high-resistance relay with a light, sensitive armature, a very reliable outfit is the result.

Returning for a moment to the RK62 tube, it may be said it was this tube that produced three winners in the radio control contests of the National Model Airplane Championship Meet in Chicago. The tube, because of its peculiar characteristics, functions both in a self-quenching super-regenerative detector circuit and as a de-

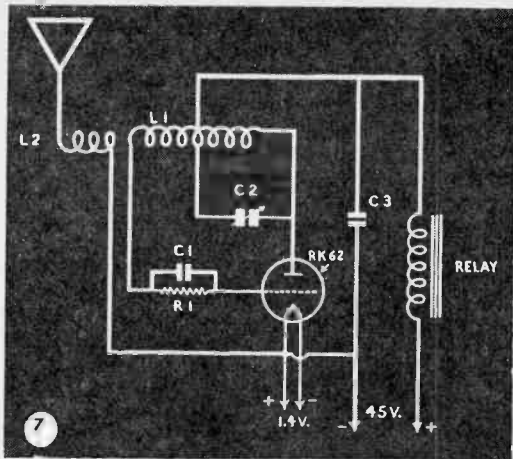

Still another receiving circuit for model control.

KEY

- L1=10 turns No. 14, 1/2 inch apart
- L2=3 turns No. 14, 1/2 inch apart
- C1=100 mmfd mica
- C2=15 mmfd mica
- C3=0.005 mfd paper

detector of tremendous sensitivity. This all spells light weight and high efficiency for model control. What is more, the circuit in which the tube is employed is very simple despite the high sounding statements made above. Not only that but the materials used in the circuit, including the tube, are inexpensive. The whole outfit may be put together for only a few dollars.

Structurally, the RK62 used in this receiver closely resembles any of the ordinary triodes. However, the RK62 contains a small amount of inert gas and under certain minimum conditions this gas has a high dielectric or insulating strength, preventing current from passing. On the other hand, when this gas becomes ionized (conductive) which it does very suddenly at a critical point, a relatively large amount of current will flow in the plate circuit and a positive function of the relay will result. This happens when the grid bias is reduced. This release of plate current is controlled by a limiting resistance placed in the plate circuit.

In this super-regenerative circuit, the tube oscillates at 60 megacycles which is in the neighborhood of frequency chosen by most of the fellows who go in for radio control. If the small number of parts used are mounted on a piece of 1/8th inch bakelite panel, the result should weigh in the neighborhood of one pound with batteries and relay included. This depends entirely upon the type and size of the batteries employed for

power. In the case of a model airplane, perhaps the builder will wish to use one Penlite cell and the Eveready X-180; the total weight of power then amounts to three ounces.

Of course, understand that as we sacrifice weight in this matter we also sacrifice life. The smaller the battery or cell, the shorter its life. In the case of a model boat or car where weight is not a vital factor, a one-inch flashlight cell is recommended along with the Burgess type V30BP. Still longer service may be had from a 1 1/4 inch flash light cell and the Burgess battery type W30FL. Here the weight would amount to thirteen ounces as compared to three ounces in the first case and seven ounces in the second case. Thirteen ounces of weight would be by no means excessive for a boat.

The photograph shows this 60-megacycle receiver complete with 6000-ohm relay made especially for this combination by a manufacturer whose name will be supplied upon written request accompanied by stamped, self-addressed envelope. Indeed if the enthusiast does not wish to make this receiver, it may be supplied without tube but including relay for about nine dollars. Without tube (very light in weight) or battery, the outfit weighs only 4.5 ounces.

The receiver illustrated in Fig. 8 was de-

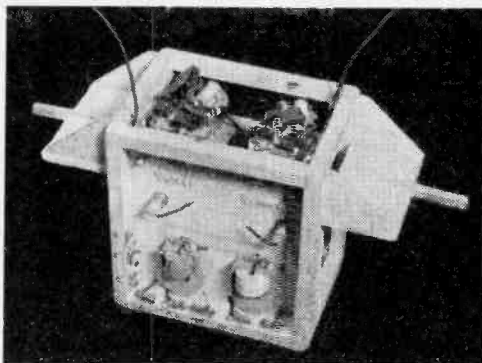

The two-channel plane receiver used in the Good brothers model airplane.

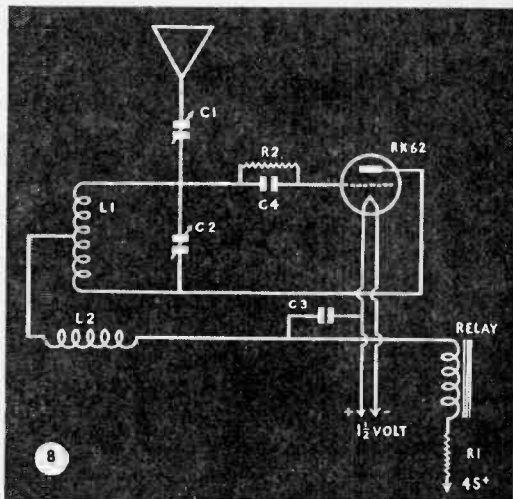

Here is another well-designed receiving circuit for radio model control.

- C1=Antenna trimmer in 1/2-inch form, spaced 1/16 inch between turns
- C2=Tuning trimmer L2=RFC
- C3=.05 mfd mica
- C4=100 mmfd mica
- L1=10 turns No. 14 wound R1=5000 ohm 1/2 watt
- R2=3 megohms 1/2 watt

signed especially for radio model control, by C. E. Bohlenblust of Wichita, Kansas and this, too, employs the RK62 thyratron-type of receiver tube. With this circuit and the 6000 ohm relay previously mentioned, reliable operation may be had over a distance of one mile which, on the average, is farther than is necessary for the operation of models of any kind. Long-distance flight is out of the question for model gas-driven airplanes because of the gas carrying problem.

This little receiver, as in the case of the one previously described, is light and compact, so compact indeed that it may be nicely squeezed into an aluminum shield can measuring only  $2\frac{3}{4}$  inches in diameter. The receiver, the largest

may be necessary until a suitable value is found which provides the greatest current change. In experimental adjustments of this sort it is best to separate the receiver and the transmitter to the distance equal to their normal operating distance from each other.

Figure 9 provides the hookup for still another very reliable receiver design by the Good Brothers, Walter and Bill, of Kalamazoo, Mich., for operation on 5 meters. Inasmuch as the receiver and transmitter designed by these boys was efficient enough to carry away the laurels at the 1941 Chicago meet of the National Model Airplane outfit, it at least has this recognition and record behind it. This set does not need to

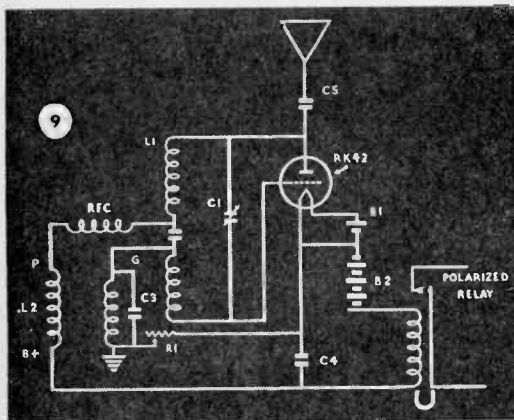

Diagram of the receiving circuit used by the Good brothers of Kalamazoo.

#### KEY

- |                            |   |
|----------------------------|---|
| C1=250 mmfd midget mica    | $\frac{3}{8}$ form, spaced diameter of wire               |
| C2=15 mmfd midget variable | L2=Interruption frequency oscillation coil (National OSK) |
| C3=0.002 mfd midget mica   | B1=1.5 flashlight cell                                    |
| C4=.005 mfd midget mica    | B2=45 volt B  |
| C5=30 mmfd midget trimmer  | R1=100,000 ohm variable                                   |
| L1=Each, 5 turns No. 14 on |   |

part of which happens to be the tube, may be mounted on a bakelite plug that fits into the bottom of the shield and the closed end of the shield can is cut away just enough to permit the top of the RK62 tube to protrude.

The large sized "D" flashlight battery may be used for filament supply. This battery furnishes constant voltage which is essential for continuous and reliable operation.

The final adjustments for this receiver before use are simple enough. Starting with no signal and with loose antenna coupling, the plate current should show well below  $\frac{1}{2}$  milliamperes. Coupling may then be increased until the plate current reads about 1.5 milliamperes. At this time, with the carrier on, the signal is tuned in, producing a lowering of the plate current. The worker will also find that some readjusting of the antenna coupling may be necessary to hold the plate current at 1.5 ma with the carrier off. Some experimentation with different grid leaks

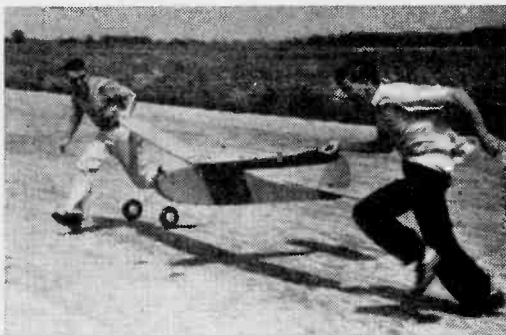

This is an assisted takeoff for a radio-controlled model airplane.

cost over five or six dollars minus the relay but including the tube.

Unlike the two sets described previously, this outfit does not make use of the RK62 tube. It does use a cousin of it, however, the RK42. The Good boys also used this set with a polarized relay; that is a relay whose armature lies constantly in a magnetic field supplied by a permanent magnet. The details of this particular relay with working instructions for its construction will be supplied in a following article. The diagram of connections for the receiver proper also carries the bill of materials needed for the construction of the set.

Here it might be said that the greatest care should be used in wiring these little sets. It is not only necessary to solder all connections but also to see that the bare wire tips before soldering are clean. The amount of current dealt with is so small that the model maker cannot afford to lose a bit of it unnecessarily. In the case of a model airplane, the soldering should also be put on sparingly. A sloppy soldering job with large lumps of adhered metal could easily place another ounce on the ship.

If the builder wishes, he may remove the base from the RK62 or RK42 tubes used, being careful, of course, to preserve the leads. If the tube base is not taken off, then at least the builder may solder his leads directly to the prongs at the base of the tube and, in this way, he can eliminate the socket.

This last receiver (the Good brothers) was



Radio controlled model plane ready to do a little flying.

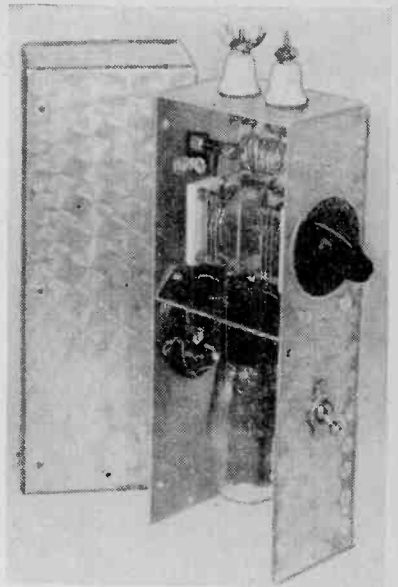

Model transmitter developed by Radio Control Headquarters, Inc.

radio control that he used to make his model plane chase seagulls!

Those who have had a great deal of experience in the control of models through the agency of the radio-transmitted impulse feel that the transmitter with fixed frequency is to be desired over those with variable features. Of course all transmitters may be arranged so that ready adjustments in wavelength may be had by tuning capacitance or inductance. When using such high-frequency current, however, one often has severe shifts in frequency and wavelength without asking for them. Such transmitters lack the stability of outfits producing longer waves. Inasmuch as we have no operator in the model to make corresponding adjustments in the tuning of the receiver carried by the model, the builder of such equipment should construct as stable a transmitter as possible. This naturally leads to the use of crystal-controlled transmitters and while successful model operation may be had without this refinement, the addition of such control makes for more trouble-free operation. What is more, crystal installation is not expensive.

used with duo-frequency channels. One channel takes care of the elevator and the other operates the rudder. For this reason, two of the receivers just described are mounted in the ship to be controlled. This sort of duo-channel control not only costs twice as much as single channel insofar as radio equipment is concerned but it must be carried by a much larger ship. Certain designs of model airplanes are more ideal for radio control than are others. The best models for this purpose are those with large wing area. Proper spiral stability is also needed and this depends on correct designing with respect to the center of gravity. The model with deep-bellied fuselage and a high location both of thrust line and the center of gravity is most apt to produce suitable spiral stability. Radio-controlled models should fly nicely in a straight line so that they may be more easily controlled from right to left.

While the Good brothers' duo-channel system does cost twice as much as the signal channel system, the cost is still not prohibitive. It might run as high as fifty to sixty dollars but such expense when measured against the fun that may be had is not excessive. One lad so perfected his

The transmitter illustrated in Fig. 10 will be found ideal for beginners in radio control because of the simplicity of the circuit and the fact that this equipment operates with a high degree of stability. This outfit used the RK59 dual purpose tube which offers excellent power output among other things. With this circuit, power supply units may be had at low cost from any of the large radio supply houses. It is better to purchase one of these transmitters complete.

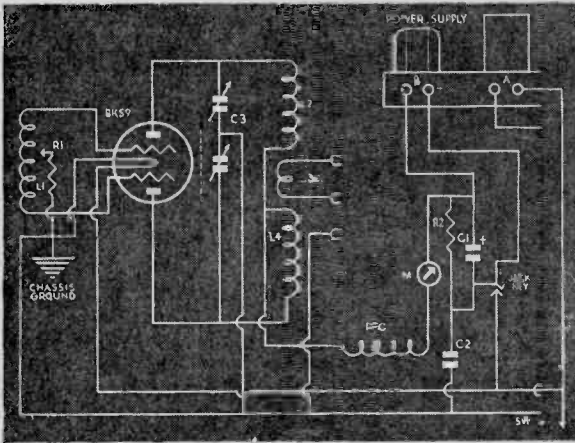

Fig. 10. Schematic diagram of a one-channel transmitter.

- KEY**
- R1 = 1 RC 5000 ohms.
  - R2 = 50,000 ohms. 25 watt.
  - C1 = 8 mfd. electrolytic cond.
  - C2 = .01 mf. mica cond.
  - C3 = dual 75 mmfd. cond.
  - L1 = 6 turns, No. 14 wire (1 1/4" long x 3/4 O.D.)
  - L2, L4 = 4 turns (1" long x 3/4 O.D.)

Not only does one save time but one also saves money because the cost of the total assembly is usually less than what you have to pay for individual parts separately.

The case in which the transmitter may be housed is more or less optional. Fine aluminum cabinets are now available and if the builder wishes to "roll his own" he can, since sheet aluminum is a drug on the market.

To give this transmitter a high degree of flexibility along with fair stability at any wavelength available, a variable coupling coil with panel control is included. This is made of four turns of No. 16 insulated wire wound on a Bakelite strip; this strip is drilled out in the center and provided with a shaft for mounting on the panel and a control knob for turning.

Flexible leads of sufficient current capacity

- KEY**
- C1, C2, C7 = 100 mmfd. mid-ge t mica condensers.
  - C3 = 35 mmfd. cen. mica.
  - C4, C5, C6, C8, C9 = .002 midget mica,
  - C10 = 15 mmfd. variable midget condenser.
  - R1 = 1 megohm 1/2 watt.
  - R2 = 50,000 ohms 2 watt.
  - R3 = 150,000 ohms 1 watt.
  - R4 = 25,000 ohms 1 watt.
  - R5 = 25,000 ohms 10 watts.
  - L1 = 9 turns No. 14 wire tapped one turn from ground.
  - L2 = 8 turns No. 14.
  - L3 = 6 turns No. 12.

are soldered to the terminals of this coil so as to permit its movement within a prescribed range. One of these leads connects to a terminal in the center of the panel and the second one carries a slip which is used to establish a connection to the grounded frame of the variable condensers.

While the inclusion of the meter will add a rather severe item of expense, its use is most helpful, but by no means vital or absolutely necessary. The point to be borne in mind here is that the meter will enable the user of the equipment to know at all times just where he stands in the matter of power radiation. This meter registers the power output, the most important check on operation. No registration means no power. The meter should have a range of 200 milliamperes. The grid coils are soldered to the grid tabs of the Isolantite socket. Note their position in the drawing.

All low-voltage connections in the transmitter are established by means of No. 10 insulated wire. These low voltage circuits carry considerable current, and voltage drop is apt to be considerable unless ample conductance is provided.

For those who are not familiar with radio transmitters it may be said that it is necessary only that they purchase the equipment listed in the list of materials on the next page and connect it as illustrated in the drawing. Every connection must be soldered in the best possible manner. The list of materials gives the key numbers indicated in the diagram of connections. After the equipment has been assembled you will want to test it. This is done in a preliminary way by checking the output. To do this,

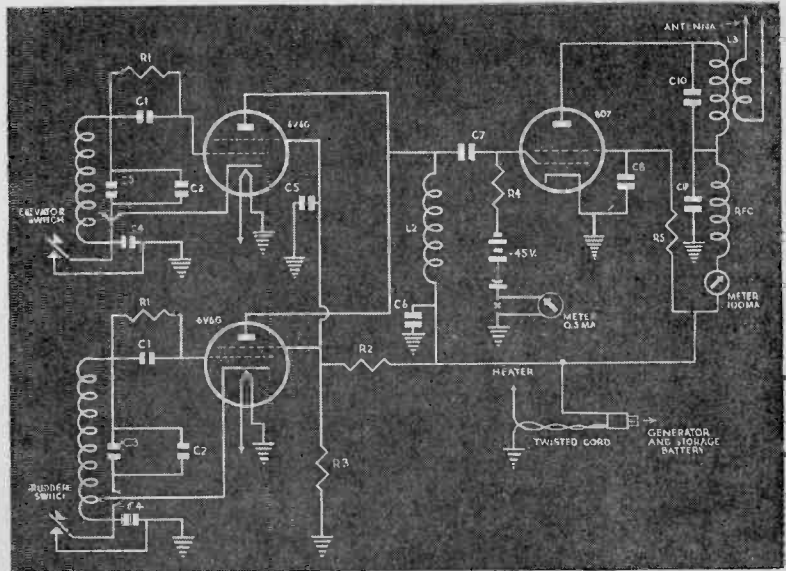

Fig. 11. Schematic diagram of Good brothers' two-channel transmitter.



one connects a 25-watt electric light to the output posts and varies the coupling until the lamp lights with maximum brilliancy. This it should do when the milliammeter registers as little as 100 ma. Output should also drop when the variable condensers are turned back to minimum capacity. In this instance, plate current will rise.

With this little transmitter practically any type of radiator may be employed. When a doublet affair is used, the two upper terminal posts are used and the clip on the end of the flexible lead is placed on the panel insulator.

The operation of the set in the field calls for constant checking of wavelength with a wavemeter. Such an instrument may either be made from directions supplied in any of the good amateur handbooks or it may be purchased complete and ready for use for a few dollars. In any case, the transmitter should be checked before each flight. The power of this transmitter using the RK59 tube is rated at about 35 watts. The high voltage will run about 400 at 90 ma.

Two young American pioneer workers in model plane radio control for model airplanes, William and Walter Good of Kalamazoo, Michigan, use two frequency-channels for control. One is for the rudder and the other for the elevator. This permits the ground operator to give his ship three-dimensional direction within reasonable bounds. By "two frequency-channels" we mean two wavelengths. To receive these signals, the ship carries a modified five-meter super-regenerative receiver. All the equipment for this set is standard except the special relay, and it may be bought in any well-equipped radio-supply shop. The cost of the whole outfit does not need to exceed five to eight dollars.

---



---

#### LIST OF MATERIALS

- Raytheon tube RK59
  - R1. 1 RC Resistance 5000 ohms
  - R2. Resistance 50,000 ohms, 25-watt
  - C1. 8 mf. microfarad electrolytic condenser
  - C2. .01 mfd. mica condenser
  - C3. 75 mmfd. dual variable condensers
  - L1. 6 turns No. 14 wire (1 $\frac{1}{4}$ " long x  $\frac{3}{4}$  O.D.)
  - L2, L4. 4 turns (1" long x  $\frac{3}{4}$  O.D.)
  - R4. 3000 ohm  $\frac{1}{2}$  watt resistor
  - R5, R6. 10-50 A. shunt
  - SW1. Three position switch
- 
- 

The plane that won the last "Nationals" at Chicago had an 8-foot spread or wing span and weighed in at slightly over 8 pounds. This figure included 2 pounds of radio-control gear. The ship carried a gasoline motor capable of developing about 1/5 horsepower. This power made possible a cruising speed of 30 miles per hour. Due to the dihedral in the main wing, such a plane will back automatically when the rudder is turned from the ground. If the controls on the ground are used with care and intelligence, a perfect landing may be effected.

If the would-be builder of a radio-controlled

craft thinks that he can buy his equipment, throw it together, and immediately enjoy the thrill of radio-controlled flight, he certainly is due for bitter disappointment. We have not yet reached the stage where such performance is possible even with the ready-made outfits that can now be had. Care, vigilance, and patience in a high degree are necessary until the operator becomes familiar with his equipment and its peculiarities. At first the control units should be tested with the plane grounded. Even after the operator has had some experience he should ground test the plane prior to each flight.

Relays of the type that must be used in equipment of this kind are never thoroughly reliable and are constantly in need of adjustment. Before each flight, the operator should make sure that



Transmitter antenna used by the Good brothers

the sensitive relay closes when the carrier waves from the five-meter transmitter are turned on. As we study this system, we shall soon discover that when the relay is actuated, it closes a circuit which permits current to reach the electromagnets previously referred to. When the latter receive an impulse and the armature is pulled forward, the rubber-powered escapement wheel, always under stress from the rubber band, is permitted to advance one-quarter, or one position. This function is brought about by the transmission of a single dash.

In the Good brothers' plane, the control units (elevator and rudder) had three main positions; left, neutral and right for the rudder. In addition, there were two intermediate positions, or five in all. It will be perfectly obvious that once a position has been reached and passed, there is no turning back. The whole cycle has to be repeated before this position can be reached again. However, this is not so much of a drawback as

one might consider, inasmuch as the positions may be reached and passed very quickly. For each dash transmitted, there is a corresponding position on the wheels, and these may be passed through in a few seconds' time. The response is quick and sure.

It should be pointed out that such a plane as the Good brothers used must have two escapement units, one for the rudder and one for the elevator. These units should not weigh over one-half ounce each.

To make sure that they will know the exact position of both the rudder and the elevator controls at all times, the Good brothers employ a five-point switch on the ground. Each point corresponds to a position of the mechanism in the air. Each time a contact is made on one of these points of the five-point switch, the correct function in the sky is carried out. Without such a simple check, it would be very difficult to exercise control at all.

After having tried many different relays for their machine, the Good brothers made their own. And here it might be said that no radio-controlled airplane is better than its relay. If the relay is unreliable, the most reliable radio transmitter and receiver will be of no avail. The relay developed in this case was of the polarized type, with a balanced armature which is not, therefore, actuated by springs of any kind. It is estimated that the relay will give a positive motion to its armature on the passage of current estimated to be less than a milliwatt. The little machine weighs two ounces and it is quite capable, as experience shows, of operating without disturbance from the engine. Relays used for this purpose must be free from the vibration set up by gasoline engines.

The receiver used in the radio-controlled plane has been developed over a long period by William Good. As has been stated before, it is a one-tube super-regenerative outfit with self-quenching circuits using quenching coils. However, the actual conditions of operation have been changed so that maximum plate current change takes place when a signal is taken in. This maximum plate current change is necessary to provide the relay with all possible energy that its armature may be moved in a positive fashion. A type 30 tube will provide a plate current change of as much as three milliamperes. The RK42 tube, recommended for use in the equipment under discussion, is really quite similar to the type 30, save that it operated on a 1.5 volt battery. Such a tube will produce a plate cur-



William Good of Kalamazoo, Michigan, holding the radio controlled model plane developed by him and his brother, Walter Good.

rent of two milliamperes through a resistance of 2500 ohms. Maximum current flow in the plate of the detector circuit is also brought about through the proper adjustment of the tuning condenser, the antenna padder, and, in addition, of the grid bias resistor.

Now for a word or two concerning the five-meter transmitter. Due to the need for portability, the power for the transmitter comes from a six-volt storage-battery. Two separate electron-coupled oscillators are employed, one for each of the wavelengths emitted. We might call one the rudder oscillator and the other the elevator oscillator. A single amplifier services both the oscillators. The two 6V6G tubes (see Fig. 11) employed are provided with a common plate tank which is broadly tuned and capacity-coupled to an 807 tube. Those who are at all familiar with radio will note that a half-wave horizontal center-fed Hertz antenna supplied with radio frequency by means of a tuned line which is inductively coupled to the final, will prove to be excellent for this purpose.

Exceptionally fine results have been secured by the Good plane. With the rudder in the neutral position, it will fly substantially straight for long periods. In the extreme right or left positions, the circles described will be practically equal. Apparently this holds true either when the ship is under full power or when it is gliding. It is to be pointed out that a performance of this kind is possible only with proper wing loading. The Good brothers also point out that a great deal of flying is done with rudder control alone. The elevator is simply not used until the proper level is reached. In the maximum position (either right or left) the little ship will gradually work itself into a large spiral which

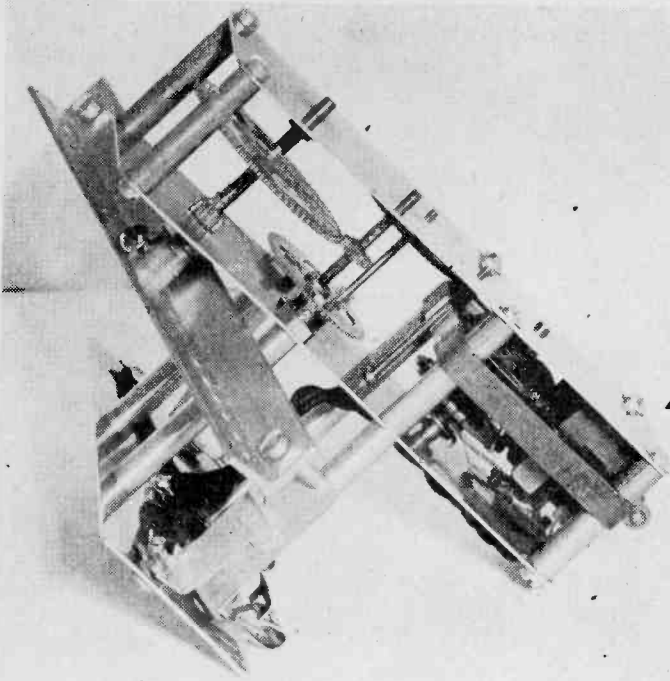

Motor and gear speed control for radio controlled model operation.

is beautiful to behold. More beautiful still is the trick of pulling it out of the spiral and making it level off at high speed.

Due to the high-speed action of the controls of this ship, landing is greatly simplified. While high-speed action aloft is not so important, it is nice to have it when the ship is five or six feet off the ground on the way to a landing. In such cases, the operator can bring about quick changes in the position of the elevator or the rudder. As a matter of fact, if he does not like the conditions under which the ship is landing, he can quickly manipulate his controls and start her skyward again. In short, the operator can maneuver his ship until just the proper conditions for a three-point landing are obtained. If the controls are working, these conditions can easily be had, if not on the first approach, then certainly on the second or third. It may take patience.

Success in the control of models by radio depends not only on a strongly transmitted and well received radio impulse but also upon a quickly responsive and sensitive relay in the receiver circuit. This relay takes the circuit position of the headphones or the loudspeaker in an ordinary radio receiver. The relay is, in truth, a very sensitive automatic switch which is closed by the incoming radio signal and which

releases local energy to dry cell (or a battery of them), this being the energy that is used for the operation of steering mechanism, etc. Clearly, the energy of the radio signal cannot be used for such purposes because of its extreme weakness even at close range. Thus the relay or remotely controlled switch which it really is must of necessity not only be electrically sensitive to a few milliamperes but must also be very reliable from a mechanical viewpoint. When the relay fails, all fails. One cause of failing relays is sticking; that is, the armature comes down, makes contact but remains there in place of returning to its neutral position awaiting another radio impulse.

Sensitive relays suitable for radio control use may be either made in the home workshop or purchased ready made. If purchased, one must make sure that the type bought is suited to the job intended for it. As an example, one intended for a model airplane should be of light weight. The

sensitivity of the instrument used is also important and must be either purchased or made with the idea of power of the transmitter versus the distance to be covered well in mind. In the case of a low power transmitter, signal strength diminishes rapidly as distance is increased.

The relay, functioning as an automatic switch, sends heavy electrical impulses to the actual control mechanism (usually an electro-mechanical combination). By this we mean that the relay in turn releases a further source of local energy either electrical or mechanical. For instance, a small electric motor or a plunger and solenoid may be thrown into motion to move a rudder or a throttle, the motor stopping when the function has been completed. On the other hand,

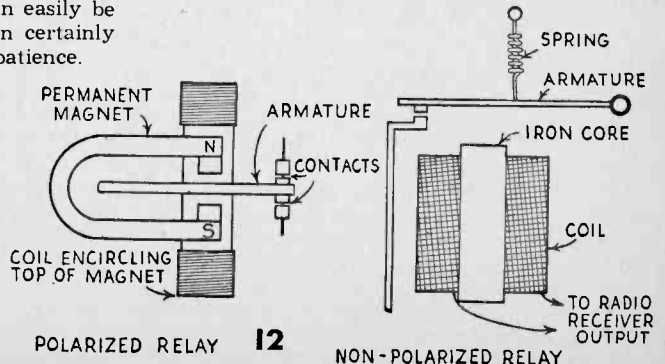

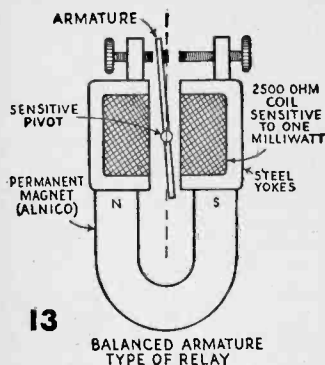

13

Plan for polarized relay using horseshoe magnet, a type of relay which is popular with radio control fans.

when extreme lightness is required as in a model airplane, the small electric motor and its battery may be far too heavy. In such cases, one may find a heavy rubber band wound up and under constant stress to be a help. A small electromagnet energized by a small dry cell, the current of which is released by means of the relay, releases the rubber band motor by means of a ratchet. The advantage here is that of weight. The electromagnet used in the release of the motor requires only a single dry cell, while the electric motor requires a battery (two or more cells). Also the rubber band motor is much lighter than the electric motor. Both in the case of the electric motor and the rubber band motor, operation through a small train of brass gears is usually had for purposes of speed and power.

Of course, if one wishes to bring a model sailing ship, a power motor boat or a model gas driven racing car under control, the factor of weight does not need to be so carefully considered as in the case of the model airplane. Efficiency and reliability is to a certain extent decreased when excessive attention must be paid to weight reduction.

Relays are divided into polarized and non-polarized, the difference being pictured in Fig. 1. It will be noticed that the non-polarized relay comprises only a simple magnet that is a coil of fine copper wire wound around a soft iron core. As the current from the radio receiver flows through this coil, a weak magnetic field is set up by the electromagnet, and this pulls the armature down; the armature makes contact closing a local circuit and permitting electric current to flow. The armature will remain down as long

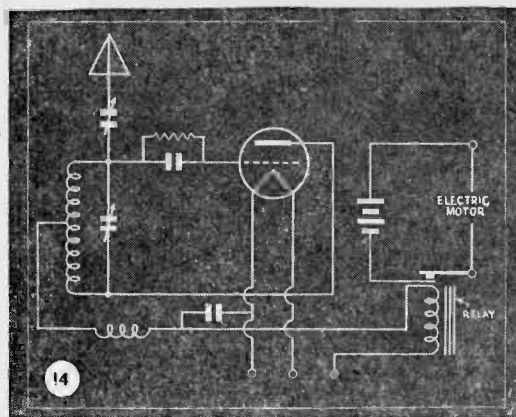
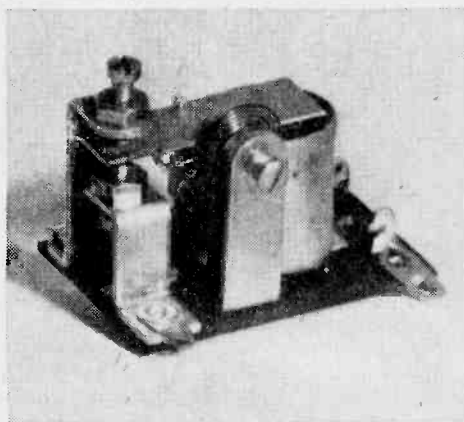

Diagram showing position of polarized or non-polarized relay in the radio circuit.



Non-polarized relay. The coiled spring brings the armature back to normal after each impulse.

mature carrying the contact shift its position, thereby closing the local energy circuit.

Although heavier because of the horseshoe magnet, the polarized relay is the most reliable of the two types. Of course, in making such relays in the home workshop, every effort must be made to reduce over-all weight to a minimum.

This means that aluminum should be used in place of brass and that light soldering often saves weight over the use of brass or steel machine screws. For airplane use, these relays are not often permitted to exceed 2 ounces in weight.

#### Separate Functions Call for Separate Controls

Due to technical difficulties in radio control it is not possible to introduce too many functions with a single radio transmitter and receiver. Better control systems usually employ two independent radio transmitters and two radio receivers. Of course, if control is simply a matter of starting and stopping, then a single transmitting channel is quite sufficient. Walter and William Good of Kalamazoo, Michigan, use a double channel for model airplane maneuvering. Two channel operation with a gas-powered model air-

as current happens to be flowing through the coil. Immediately this current ceases to flow, the magnetic field collapses and a small, delicate spring pulls the armature back to its normal position to await another impulse. There is nothing permanently magnetic about the non-polarized type of radio relay.

The polarized relay, on the other hand, utilizes a permanent magnet, usually of the horseshoe type. Thus the armature is at all times in a magnetic field. What moves the armature is the electromagnet which receives the radio signal current, the latter setting up a magnetic field which interacts in such a way with the magnetic of the horseshoe magnetic as to make the ar-

plane permits three-dimensional operation.

The simple wiring diagram used by the Good boys in their receiver (using polarized relay) is illustrated in Fig. 13. The relay in turn operates a rubber band motor through an electromagnetically controlled escapement mechanism.

In the Good brothers' plane, the control units (elevator and rudder) had three main positions, left, neutral, and right. Then there were two intermediary positions, or five in all. It will be perfectly obvious that once a position has been reached and passed, there is no turning back. The whole cycle has to be repeated before this position can be reached again. However, this is not so much of a drawback as one might consider, inasmuch as the positions may be reached and passed very quickly. For each dash transmitted, there is a corresponding position on the wheels, and these may be passed through in a few seconds. The response is quick and sure.

It is to be pointed out that such a plane must have two escapement units ( $\frac{1}{2}$  ounce each), one for the rudder and one for the elevator.

To make sure that they will know the exact position of both the rudder and the elevator controls at all times, the Good brothers employ a five-point switch on the ground, each point corresponding to a position of the mechanism in the air. Each time a contact is made on one of these points of the five-point switch, the correct function is carried out in the sky. Without such a simple check, it's hard to control.

The relay developed by the Good brothers is of the polarized type, with a balanced armature which is not, therefore, actuated by springs of any kind. It is estimated that the relay will give a positive motion to its armature on the passage of current estimated to be less than a milliwatt. The little machine weighs two ounces and it is quite capable, as experience shows, of operating without disturbance from the engine. Relays used for this purpose must be free from the vibration set up by gasoline engines.

Those who do not have a license to operate radio transmitters are warned to consult the proper authorities. Seek out the assistance of a nearby radio "ham," who would have the authority, the skill and operational knowledge.

#### Escapement and Rubber Band Motor

Reference to the article in the October issue will acquaint the reader with the basic principle of the escapement and rubber band motor. The rubber band motor is wound up before a ship takes off and the shaft upon which the rubber bands are mounted and to which they supply torque is provided with a small notched control disc, an electromagnetically operated pall engaging one of the notches on the control disc. This pall or dog is lifted by electromagnets when it becomes energized, due to the reception of a radio impulse. Of course, when the pall is lifted, the rubber bands tend to untwist and thereby supply a small amount of power to turn a rudder or "supe" up the engine.

With the larger di-pole, the elements are self supporting up to 36 in., but beyond this, it is necessary to support the elements with string or other means. The smaller di-pole was intended for use with frequencies from 100-megacycles and up. The elements can be drawn out to

## Portable Di-Poles for TV and FM

Here's how you can make a set of adjustable di-pole antennas

By ARTHUR TRAUFFER

**H**ERE are just about the most compact, thoroughly portable and adjustable FM and television di-pole antennas ever developed. Both of these di-poles use common "roll up" steel tape rules, and the tapes themselves serve as the di-pole elements. When using the larger tapes, the elements or rules can be pulled out to any desired length up to 6 ft., and they will stay out until pressure on the release buttons snaps them back into the cases. Since the rules are calibrated in fractions of inches, you can easily balance each element electrically, that is, get both elements exactly the same length. It makes little difference whether the di-pole elements consist of tubing, solid rod, wire, or tape. The important thing is that the elements be metallic, and both the same length. For portable FM and television receivers, these di-poles are ideal.

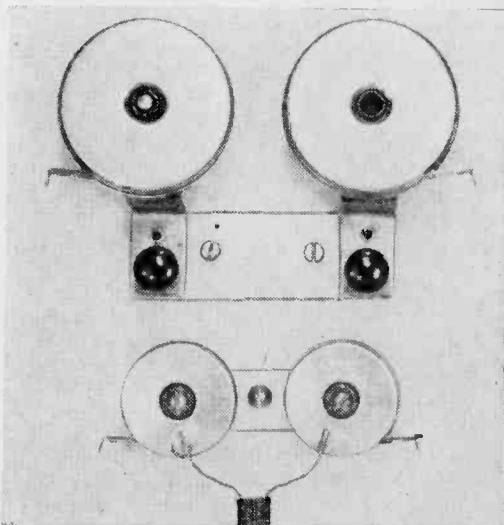

The large and small di-poles photographed together to give size comparison.



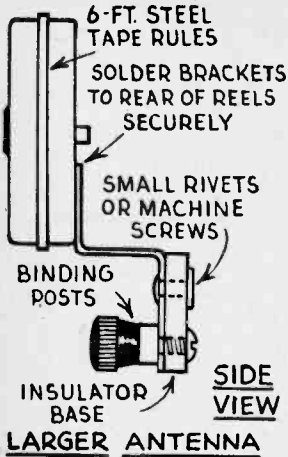

**MATERIALS LIST — PORTABLE DI-POLE ANTENNAS**

**Large Antenna**

- 2—6 ft. Walsco metal-encased steel tape rules—about 45c each in all dime stores.
- 1—Length of 1"x $\frac{1}{16}$ "x12" Polystyrene strip—about 40c in radio stores. Sold only in 12" length. Lucite or Plexiglas can be used.
- 2—ICA Bakelite binding posts, about 12c each.
- 2—Flathead tubular rivets. Brass or copper about  $\frac{3}{16}$ " long. Sold in auto stores, or can be had in auto repair shops.
- 1—2"x3" piece of sheet metal for angle-brackets. Brass or steel about  $\frac{1}{16}$ " thick.

**Small Antenna**

- 2—"Little Pal" 3 ft. Walsco metal-encased steel tape rules. 20c each in dime stores. Polystyrene strip listed above can be used if desired, or buy a 12" strip  $\frac{3}{4}$ "x $\frac{1}{16}$ " for about 30c.
  - 2—Roundhead machine screws with hex. nuts, 6-32  $\frac{3}{4}$ " long.
- Note: Polyethylene ribbon twin-lead for above antennas can be any length within reason. 300 ohm twin-lead sells for about 3c per foot. Prices listed above are approximate.

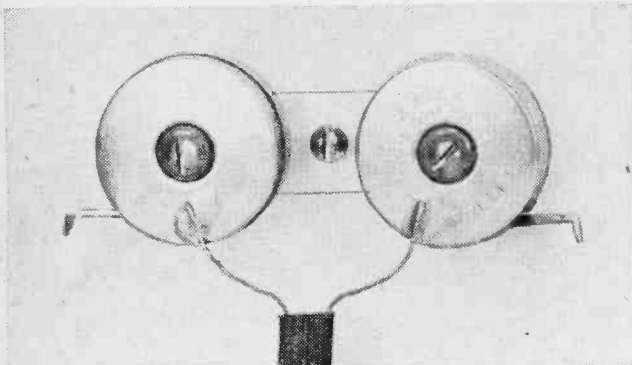

36 in. and they are self supporting up to 24 in. As the smaller steel tape rules contain no mechanism for locking the tapes when extended, it is necessary to push a small wedge between the tape and the opening in the case after the tapes are extended (wooden matches will do).

For the larger di-pole, mount the tapes on brackets with two bends in them in order to hold tapes out far enough so you can get at one of the tape-release-buttons with your finger. Use any good insulating material, Polystyrene, Lucite, Plexiglas, or Bakelite, for the insulator base, remembering that strength is perhaps more important than dielectric qualities because center of di-pole is at a low voltage node. A binding post and a small flat-head tubular copper or brass rivet hold each bracket securely to the insulator base. Binding posts make electrical contact with the tapes through the brackets

When attached to the rear of the radio-phonocombination console, the antenna is almost hidden, the elements are easily adjusted for length, and the elements can be made to disappear when the cabinet must be moved.

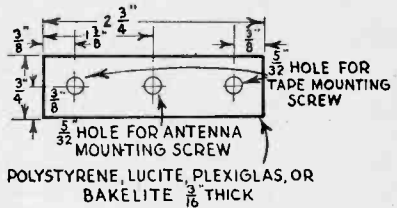
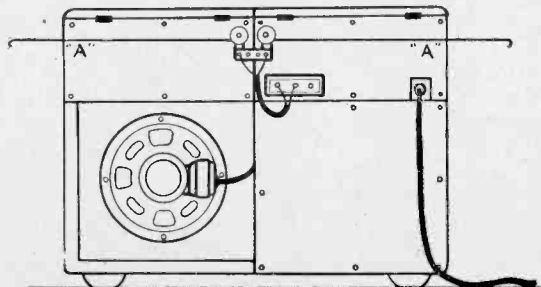

**INSULATED BASE - SMALLER ANTENNA**

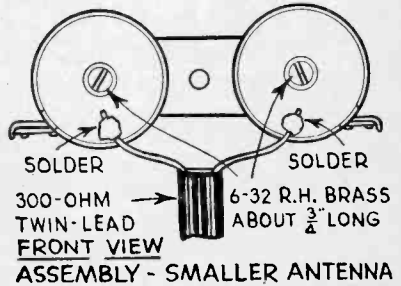
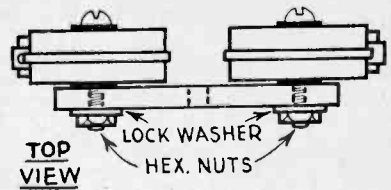

which are soldered to cases of tapes. A 300 ohm ribbon lead-in is used to connect di-pole to antenna input of receiver. After holes are drilled in the bases, di-pole can be mounted on rear of receiver, on the wall, or onto a stake which has been driven into the ground. Wood-screws or machine-

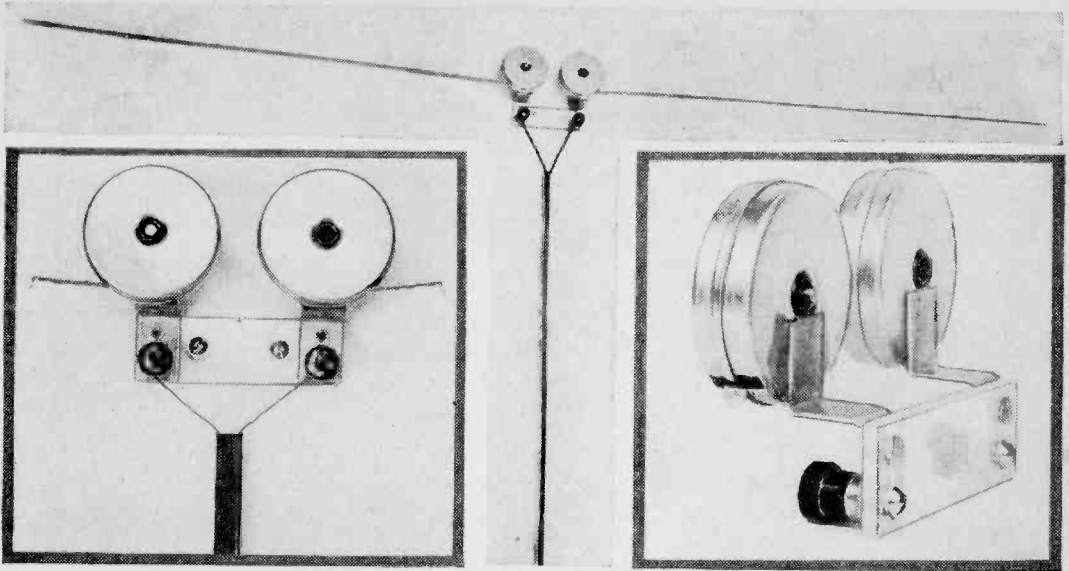

Left, front view of larger di-pole; right, rear view. Center, the large di-pole on the wall of the author's den. The elements are pulled out to 24 in. for the high end of the 88-108 megacycle FM band.

screws are used depending on where you mount the di-pole.

In constructing the smaller di-pole, since there are no tape-release-buttons on these small tapes, it is not necessary to mount the tapes on brackets; tapes are simply attached to insulator base with two round-head brass machine-screws, lock washers, and nuts. Then solder 300 ohm ribbon lead-in directly to tape cases as shown. After tapes have been drawn out to the desired length, lock them in position by pushing a match into the opening of each tape case. Tapes will snap back into cases again when matches are pulled out. Both the larger and the smaller tapes used by the writer are made by a well-known firm and they are sold in all dime stores.

**Polystyrene Tubing Insulates Chokes**

• To protect the metal ends of an RF choke from accidental contacts in a crowded radio chassis saw a

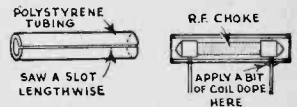

lengthwise slot on one side of a length of polystyrene tubing, and slip it over the RF choke. For straight-wound chokes, 1/2 in. OD tubing is about right, but for pie-wound chokes use larger tubing. Coil-dope or speaker-cement applied to wire leads where they enter tubing keeps tubing from slipping off choke. Or, heat the ends of the tubing and pinch them shut.—ARTHUR TRAUFFER.

**Improved Rheostat from Pencil Lead**

• A rheostat for experimental work can be quickly made with the carbon stick removed from a lead pencil. The resistance of a full length pencil varies from six to forty ohms, depending on the grade, a soft lead having a lower resistance than a hard lead.

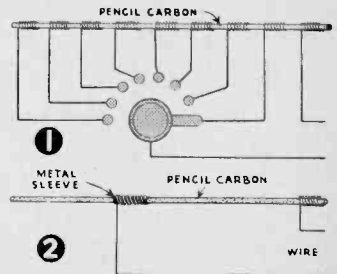

The rheostat can be constructed as shown in Fig. 1. A number of turns of wire are wrapped around the carbon shaft (these may be soldered together if current used is not sufficient to melt solder), and the other end connected

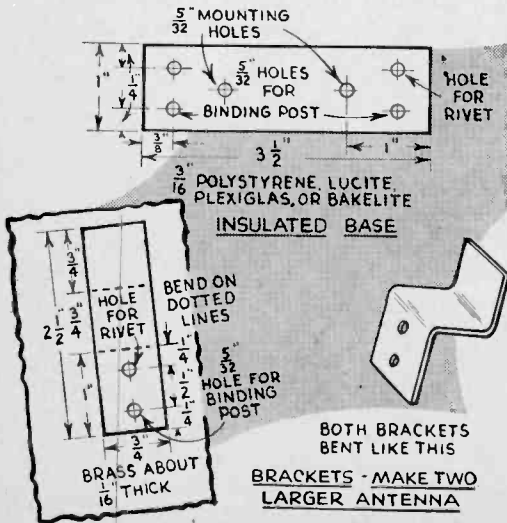

to terminal as shown. Small sleeves may be substituted if desired. Either sleeves or wire coils are movable. Since the spacing between sleeves determines the resistance between each two points, such spacing may be varied to meet requirements. Fig. 2 shows another method that may be employed to obtain variable resistance. Sliding sleeve on carbon rod varies resistance.

**Multiple Rods**

If several carbon rods are used in series or multiple, or both, any desired combination of resistance values may be obtained. Carbons should preferably be mounted on small brackets; this adds to the appearance, dissipates heat more readily and affords protection against breakage.—WESLEY J. REDEIR.

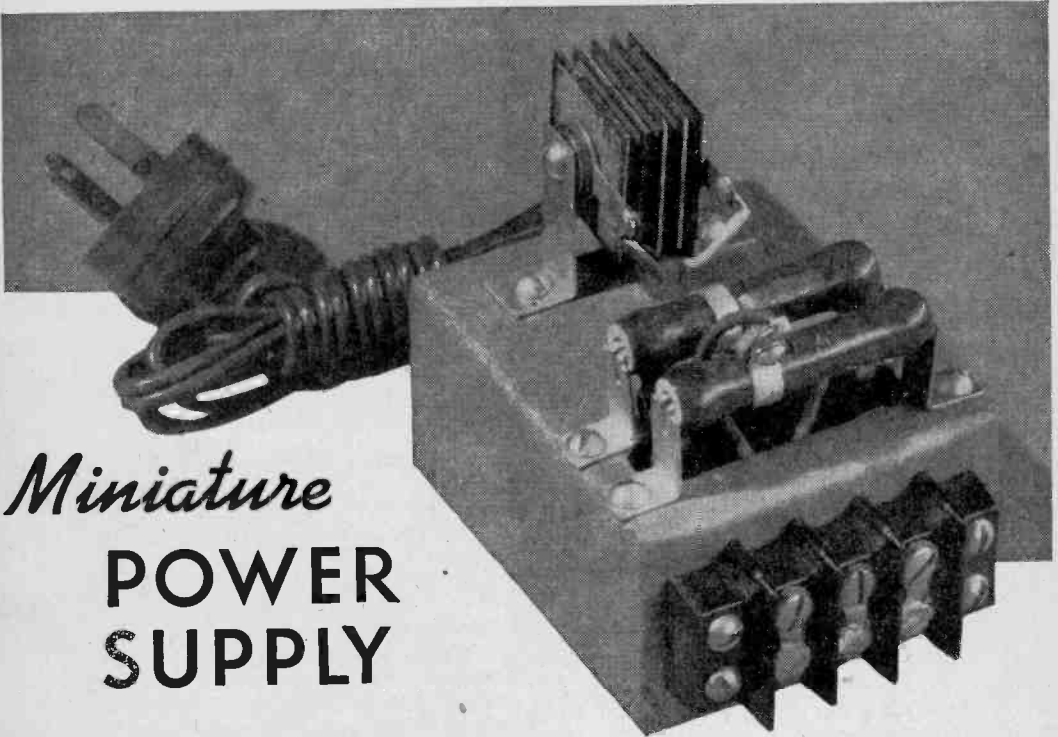

*Miniature*  
**POWER SUPPLY**

By T. A. BLANCHARD

**N**OT so many years ago, when all-electric radios were the latest thing, ambitious manufacturers placed on the market a host of *B Eliminators* which permitted owners of battery sets to operate from the power line. Some of these units were *A & B Eliminators*—and all

of them weighed anywhere from 15 to 40 pounds! Radio, however, has made a lot of progress since the 20's. In the accompanying photos you see a power pack that does all the things that many bulky units did in days past, with but a fraction of the components and about one-thousandth the weight. The unit to be described sets in the palm of your hand and its weight is measured in ounces!

Heart of this Lilliputian power unit is its selenium disc rectifier. While selenium rectifiers are not new, it was not until the war that they came into their own in this country. Before then, we were content to use copper oxide units for the most part, even though selenium units had a number of advantages. Chief reason for our abstaining from selenium was cost. In Europe, selenium units had been in use for years, but in America it took a war

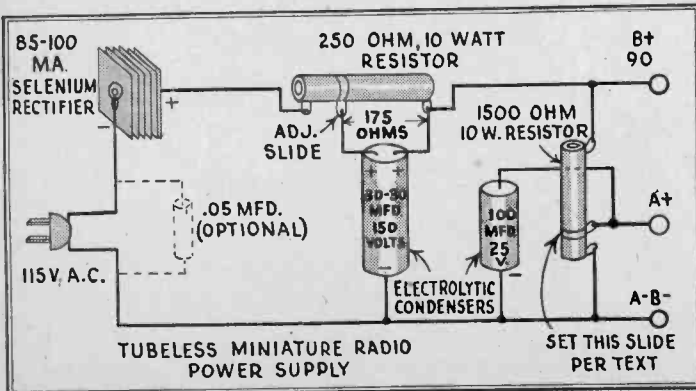

## LIST OF MATERIALS

- 1 small metal chassis (see text)
  - 1 3-post terminal strip
  - 1 85 or 100 M.A. selenium rectifier
  - mid., 150 volt electrolytic condenser
  - 1 50 or 80 mfd., 25 volt electrolytic condenser
  - 1 250 ohm, 10 watt adjustable resistor
  - 1 1500 ohm, 10 watt adjustable resistor
  - 1 length of fixture cord and plug
  - 1 .05 mfd., 600 volt paper condenser for use when line noises are to be kept at a minimum
- Miscellaneous hardware

to put them on a mass production basis. Today, selenium rectifiers are cheap, and in wide use in post-war products. In fact, this rectifier has achieved a paradoxical effect in radio manufacturing. Engineers are developing miniature battery receivers, but these sets will never operate off cells. The circuit design is the same as used in the compact personal sets made prior to the war, including the miniature battery tubes. However, built into the set is a selenium rectifier to supply both D.C. low voltage to the tube filaments, as well as 90 volts D.C. to the plate circuit.

This novel use of battery type tubes on an A.C. radio has several distinct advantages. First, the set plays the instant the set is turned on. There is no warm-up period. Secondly, the small battery tubes do not emit a lot of heat as do other tubes. And being small, these tubes occupy little floor space on a chassis. Other components can be

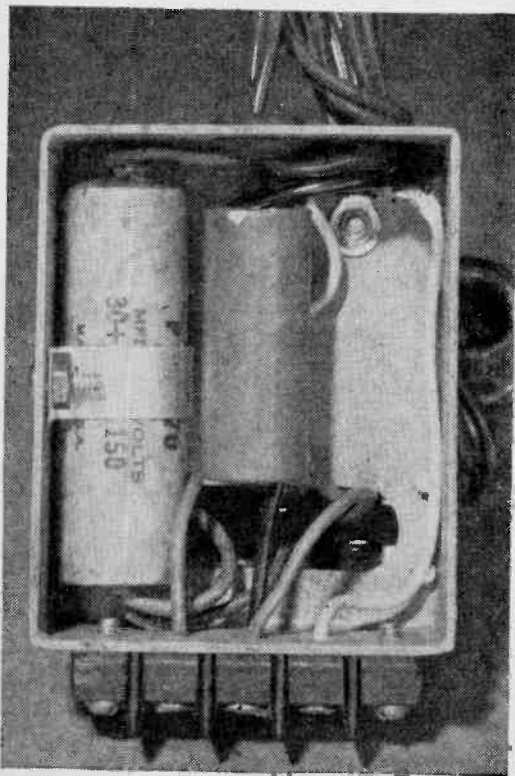

reduced in size or mounted more closely since high ambient temperatures are minimized.

The power unit described here is practically identical to those used, or to be used, in commercial sets just described. It has been assembled on a small metal chassis (2½x3x1½ inches) to make a convenient unit for the radio experimenter. The parts have been held to a minimum so as to make for the simplest and most efficient type unit. You can follow our design, or assemble the power unit on a chassis, or in a battery set. So long as the wiring plans are followed faithfully, there is no reason to bore you with trivial mechanical details.

The half-wave selenium rectifier used here is rated from 85-100 milliamperes output and costs about \$1.50. Unlike a tube, it won't break and will last for years. The other essential units consist of two adjustable 10 watt resistors, and two electrolytic condensers.

By employing adjustable resistors, we have eliminated two extra resistors of similar size from the circuit. The circuit as shown employs a 75

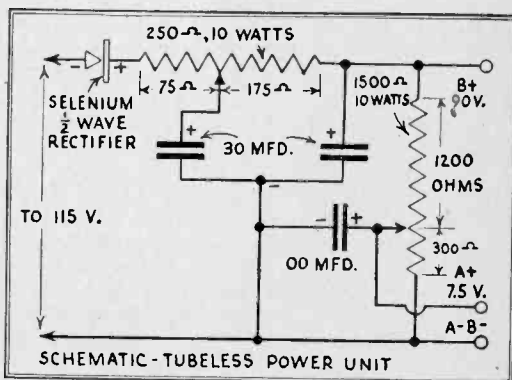

ohm limiting resistor after the rectifier, followed by a 175 ohm resistive filter between the 20 mfd. electrolytic condenser sections. Using a single 250 ohm resistor with adjustable band, we set this band, using a ohmmeter, to give us a 75 ohm tap near one end. The band is then screwed up tight. If you don't have a meter for the purpose, your parts dealer can measure this resistance.

The load resistor has a value of 1500 ohms and likewise takes the place of two fixed resistors (1200 and 300 ohms). However, unless this power pack is to be used to furnish filament voltage to a string of 4 or 5 miniature tubes, the band is not preset with an ohmmeter to give a 300 ohm tap.

Tubes obtaining their "A" power from this pack must be wired in series, and must be of the low current type (50 milliamperes, or .05 amps.). Anywhere from one to five tubes may work off this single unit, but for less than five tubes the adjustable tap must be moved closer to the ground (See A—B— in the drawing).

Brackets are furnished with the resistors so that they may be conveniently mounted. The selenium rectifier stack has an eyelet opening through the center so that it may be mounted

with one or two homemade brackets and fastening with a brass screw. Caution—when using a selenium rectifier be sure that the fins are not shorted together or touching the chassis or any other wires or components in the circuit.

Parts are mounted according to the general arrangement we have used, with rectifier and resistors on top of chassis and electrolytic condensers underneath. Some heat will be given off by resistors and rectifier, which is natural. However, if this power pack is used to furnish only B battery supply (90 volts), you may eliminate the 1500 ohm resistor entirely, and use a 1 watt, 1,000 ohm midget resistor in place of the 250 ohm unit. In the latter case, one 20 mfd. section of the electrolytic condenser connects between the plus side of the rectifier and the new resistor instead of going to the tap as in the conventional hook-up.

A 3-post terminal strip was mounted at one end of the chassis for easy connection of set to power unit. Lefthand terminal is A—B—, center terminal is A plus and righthand terminal is B plus. Cord extends through rubber grommet in rear of chassis for plugging into 115 volt A.C. outlet.

Following tube data available from manufacturers, many battery sets can be converted to use the newer miniature tubes. Sets now using such tubes must be rewired to place all tubes in series. Such rewiring of the tube filaments should be attempted only when proper test equipment and experienced workers are available.

Under actual operating conditions, if, upon testing, it is found that this supply is delivering more than 90 volts install an extra clamp on the 1500 ohm resistor and move this tap slowly toward the ground end until 90 volts are measured on the testmeter. Be sure to turn the power off when changing this tap.

The radio experimenter may affix extra clamps near the upper end of the 1500 ohm resistor to provide 45 and 22 volts in addition to 90 volts.

*Determining the position for filament tap:* Set slide as far toward A—B— end of resistor as possible. Connect set to power unit and plug-in. With a good quality voltmeter across A+ and A—B— terminals, slowly move slide upward, watching meter. At 1.4 volt reading, lock the adjustable tap if set is one tube, or 2.8 volt for 2-tubes, 4.5 volt for 3-tubes, 5.6 volt for 4-tubes, and 7 or 7.5 volt for 5-tubes. Voltage reading must be made with tubes connected.

Many battery sets now on the market use 90 volts for the "B" supply and 9 volts for the "A" supply. This unit will make an excellent battery eliminator for such units provided the tubes used in the set do not draw more than 50 milliamperes. The "A" tap is then adjusted to 9 volts.

Besides making a good battery eliminator for certain types of battery operated receivers this unit can be of great use to the experimenter as a source of "A" and "B" power for one and two tube sets. A ground wire must not be used with any unit using this power supply because one side of the AC line is connected to the A—B— terminal which is connected to the chassis.

## Handy Reel for Solder

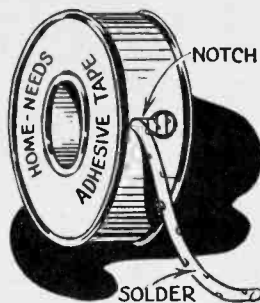

• Small household packages of solder that are not regularly supplied on a reel can be transferred onto a handy dispenser and holder by coiling them on a used adhesive tape reel as shown in the drawing. This does away with much of the direct contact with the solder and any escaped flux. Cut a hole at the side of the can for uncoiling the solder. A wedge-shaped notch at the side of the hole will lock the solder from receding back into the can.

## Keeping Wire Solder Handy

• By supporting the spool of wire solder by wire hangers beneath the top of your metal working bench, and running the end through a hole

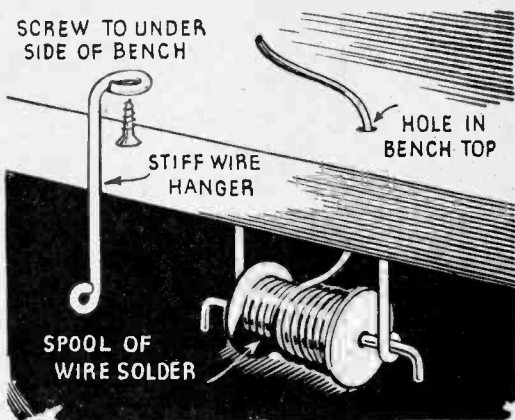

in the bench, you will have solder always within handy reach. A bend in the end of the wire will prevent its slipping through the bench.

## Soldering Flux in a Spool

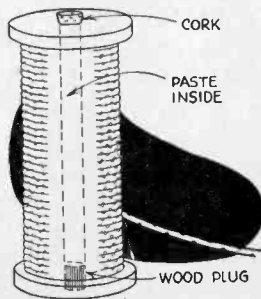

• Soldering flux, in paste form, can be kept inside of the hole in the spool, on which the wire solder is wound. Tightly close one end of the spool with a wooden plug and insert a small cork in the other end. Time and space can be saved by this arrangement, and the flux and solder wire are always together.

105 North Street  
Coral Grove, O.

JACK BRYANT



# Home Built RECORD PLAYER

A record player is a real addition to any home. Here are the instructions for building an attractive, high fidelity player for your home

By HAROLD P. STRAND

**T**HERE is considerable pleasure to most people in hearing their favorite musical selections or other form of entertainment anytime they feel in the mood. It is especially nice if the recordings have a good rich tone like the expensive machines on the market. One that compares favorably with any of them can be built in the home workshop at moderate cost by the home mechanic who has had some experience in electricity or radio and can do simple woodworking. Then, too, there is nothing like the satisfaction in



Fig. 1. Its convenient height makes this phonograph very handy to operate from an arm chair.

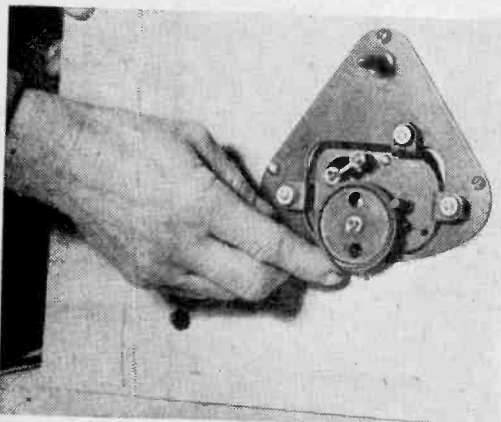

Fig. 2. The motor is simply fitted in the panel by cutting a hole large enough to clear the motor and using three short machine screws for attachment. A friction wheel drives the turntable.

being able to say that you built it yourself.

The one illustrated and described does not incorporate an automatic record changer, but by using a cabinet which provides an increased height in the upper compartment, it is possible to add such a device which can be operated through the same amplifier and speaker shown. This will add somewhat to the cost, but may be worth it to some people.

The main units, which have to be purchased, are a pick-up arm of the crystal variety, a motor and 9 inch turntable, and a good permanent magnet type of 8 inch speaker. The amplifier is built in the shop from the parts list supplied. The cabinet originally was a low priced record cabinet, which is commonly sold in most department and furniture stores today. This was rebuilt to suit our needs as shown in the photos and drawings. After doing the work outlined on the cabinet, it was refinished in a rich antique ivory.

Figure 1 shows the completed player in use. Figure 2 shows the start of the job, with the motor being fitted in its panel and secured with 3

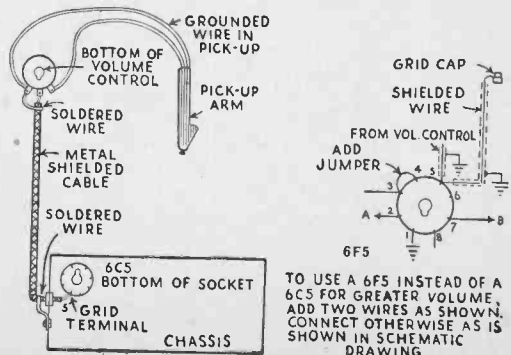

TO USE A 6F5 INSTEAD OF A 6CS FOR GREATER VOLUME, ADD TWO WIRES AS SHOWN. CONNECT OTHERWISE AS IS SHOWN IN SCHEMATIC DRAWING

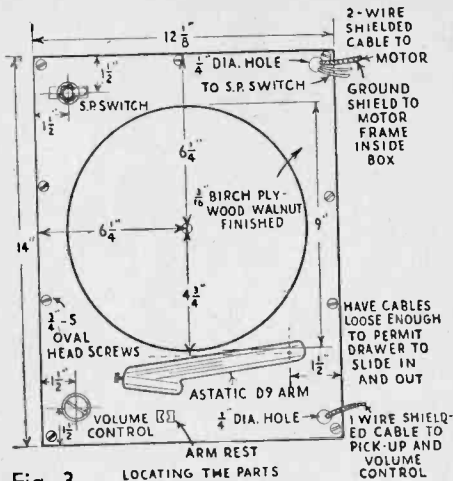

Fig. 3  
LOCATING THE PARTS  
ON THE MOTOR PANEL

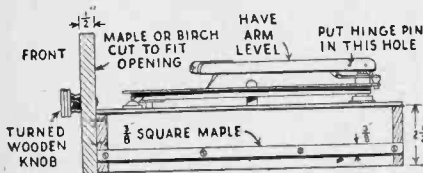

Fig. 4. The motor, turntable and pick-up arm have been fitted in place on the finished panel. See the drawing for proper location of the arm.

short machine screws, washers and nuts. The exact size of panel isn't too important at this time, as it will be cut down to fit the top of the shallow box, which houses the motor. This panel should be clear grain birch plywood  $\frac{3}{16}$  inch thick and around 17 x 15 inches or so. After all fitting has been done, the top surface is finished in walnut. The motor can be purchased for around 4 to 6 dollars, which includes the turntable. It should be rubber mounted, to minimize noise of operation. A friction wheel bears on the inside surface of the turntable rim; this wheel is shown being touched by the finger in Fig. 2.

Before doing any cutting or drilling on the

panel, consult the drawing, which gives dimensions and proper location for the turntable, arm, and controls. These measurements are important in order to be able to get the sliding unit to fit in the available space in the cabinet, and also to provide space enough to take records up to 12 inches in diameter.

Finishing of the panel can be best accomplished by removing the motor after it has been fitted in place and completing the finishing on the panel before replacing it. Apply a coat of walnut stain after the surface has been well sanded and allow this to dry about ten minutes. Rub off all surplus stain with a clean cloth so the grain will be visible. Set this aside until thoroughly dry. Then apply a coat of thin shellac as a sealer. After drying again, apply two coats of good varnish, allowing enough time between coats for drying, and sanding the first coat lightly before applying the second. After 48 hours, the second coat is rubbed to a rich semi-gloss with pumice and water, using a block of felt as a rubbing block. Take care not to rub through the varnish, stopping frequently to rub off the surface with a dry cloth, so as to check on the progress of the rubbing. Upon completion, a brisk rubbing with a

#### LIST OF MATERIALS

- 1—power transformer, 600 v. 50 ma., 5 v. 2 amp., 6.3 v. 2.5 amp.
- 1—8" permanent magnet speaker, Jensen, Magnavox or other standard make.
- 1—30 henry choke, 75 to 80 ma.
- 1—motor and turntable about 9" diameter or larger.
- 1—crystal pick-up arm.
- 1—universal output transformer.
- 3—8 pin sockets.
- 1—5Y3 tube.
- 1—6F6 tube.
- 1—6C5 or 6F5 tube (depending on volume desired).
- 1—500,000 ohm volume control.
- 1—S.P. toggle switch for panel mounting.
- 1—12 mfd. electrolytic capacitor 450 volt.
- 1—20 mfd. electrolytic capacitor 450 volt.
- 1—5 mfd. electrolytic capacitor 50 volt.
- 1—8 mfd. electrolytic capacitor 450 volt.
- 1—25 mfd. electrolytic capacitor 50 volt.
- 1—.05 paper capacitor 400 volt.
- 1—.1 paper capacitor 400 volt.
- 1—500 ohm 5 watt resistor.
- 1—2500 ohm 1 watt resistor.
- 1—10,000 ohm 1 watt resistor.
- 1—50,000 ohm 1 watt resistor.
- 1—500,000 ohm 1 watt resistor.
- 1—chassis  $12\frac{1}{2} \times 4\frac{1}{2} \times 2$ ", heavy sheet steel.
- 30" single-conductor shielded cable, about #18 or 20.
- 30" two-conductor shielded cable, #18.
- Odd lengths of stranded #18 and 20 insulated wire for connections.
- 1—cabinet made or purchased to suit taste.

#### NOTE—

Speaker used by author was Jensen No. ST 569 sells for under \$5.00, or about \$4.50.

Motor-turntable unit used was, Ballentine Phone Drive, Russell Elec. Co., Chicago, Ill. Lists for around \$7.00 complete.

Pick-up arm used was, Astatic-D 9 with a L-26-A cartridge. Lists at \$4.95.

Most of the other small parts were taken from old radios, tested and then used. Cabinet cost was \$8.95.



vary as much as 25% without affecting operation. In wiring make all connections as short and direct as possible. Avoid running grid and plate leads together or crossing them up with leads carrying filament current. Remember that the grid is most sensitive to any foreign power source, and must be kept away from other wiring and often shielded to avoid hum and squeals. Solder all connections, using rosen-cored solder rather than paste and ordinary solder. Wiring passing through the chassis should be protected with rubber grommets or composition bushings. The line cord is a length of two-conductor No. 18 rubber cord. The toggle switch is cut in on one side of line as indicated in the diagram and serves to open or close the line to both the amplifier and the motor. A single conductor shielded cable is used to supply the volume control and pick-up crystal as detailed in one of the drawings. The insulated wire in the cable connects the grid of the 6C5 tube with the center terminal of the volume control. The metal shielding serves as the grounded conductor as shown. Another shielded cable containing two wires is used for supplying the motor. The two wires connect to the motor winding and the shield is used to ground the motor frame. A short jumper soldered to the shielding at the chassis end connects to the latter to complete the grounded circuit. At the pick-up, one of its wires will usually be found grounded to the cartridge surface and the other is insulated. Be sure to connect this unit as shown in the drawing or touching the arm with the hand will cause an annoying hum. The wiring going from the amplifier to the top unit should be made long enough so the drawer can be pulled in and out with enough slack wire.

A view of the completed amplifier is shown in Fig. 5. The power transformer is at the left and next to it, the 5Y3. The choke is next in line to the right and next to this is the 6F6. The 6C5 is at the extreme right, so the leads from the volume control connecting to this tube will be short. The line cord comes out the opposite end of the

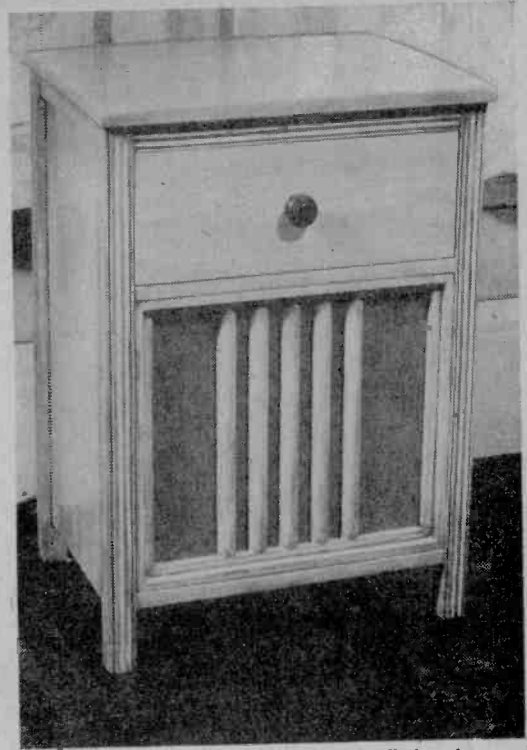

Fig. 7A. The finished cabinet, with all the player components installed, makes an attractive addition to any living room.

chassis. Holes in the chassis were drilled for ventilation. The three wire groups shown at the front side are from left to right respectively, motor leads, switch leads and speaker leads. In Fig. 6, an underside view of the amplifier wiring is shown. In connecting electrolytic capacitors, be sure to observe the polarity markings. Before turning on any power make a thorough check with the diagram and have the speaker and all connections completed.

The first test of the record player is made with a temporary set-up as shown in Fig. 7. The speaker is mounted in a section cut from a corrugated carton and connections are twisted up and taped. Turn on the power and wait a few seconds. If everything is all right, touching the needle with the finger should produce a loud click in the speaker. If no sound can be heard, shut off the power and look for an open circuit or an error in wiring the circuit. Some adjustment may have to be



Fig. 7. The speaker is mounted in corrugated carton. The motor and the amplifier units are then fitted together in this temporary set-up.

made to get perfect reception, especially experimenting with the taps on the output transformer. Tone should be rich and full and be controlled in volume from a whisper to volume enough to fill a dance hall if desired. There should be little or no hum. Grounding motor and speaker frames to chassis should overcome any tendency to hum. Keep volume control away from all other wiring. Buzzing and vibration noises from the speaker are usually due to loose mounting or loose edges close to the speaker, or possibly an improperly centered cone.

If all tests prove satisfactory, the next step is to obtain (or make) a cabinet. The author found that an inexpensive record cabinet purchased in a local store could be made over into an excellent player cabinet, and the result can be seen in the following photos and Fig. 1. Figure 8 shows the cabinet as purchased with its original walnut finish. The slats on both sides were removed and plywood panels fitted in their place. The top of the panel was fitted in the groove in the top rail originally used to hold the top ends of the slats. Support for the sides was furnished by gluing and screwing strips down the sides of the corner posts for the panel to rest against. Hot glue was used to hold the panels in place, using suitable clamps.

Figure 9 shows the cabinet with the new panels and front grill in place; the surface is being sanded. The grill is constructed by taking some 1/2 inch stock, making two frames of different sizes and then fitting one back of the other, to give a two-step effect. The vertical grill bars are made by taking some 1 inch dowel rods and slitting them lengthwise to get half round stock. These are placed as shown and held with glue and brads or short small dowels inserted in the inner frame as it is put together.

The finish selected was antique ivory, which is done by first applying a coat of flat ivory over the well sanded surfaces. Follow this with two coats of light ivory enamel. After thorough drying, take some burnt umber, diluted in turpentine, and dip a rag in the mixture. Taking one side at a time or a small section, smear the surface with the umber. A small brush may also be necessary to get in the corners. Before this has had time to dry, take a clean rag, dampen with turpentine and wipe most of it off, rubbing lightly and with the grain in full even strokes. Traces are left here and there, especially in the corners and lightly on the surface, which should look like light grain markings. If skillfully done a beautifully rich finish will result with a semi-gloss sheen that you will find is very pleasing.

Installing the parts in the cabinet should present no difficulties. The speaker is mounted on a piece of 1/2 inch insulating board (Celotex or similar material), with a carefully cut out hole in the centre. Use machine screws and nuts and washers to hold the speaker to the baffle board and wood screws to secure the latter to back side of the grille molding, after first gluing in the gold

# SAVE ON EVERYTHING IN RADIO, TV & ELECTRONICS AT NEWARK ELECTRIC CO.

Largest Authorized Distributor  
of All Standard Brand Equipment!

**FINEST  
EQUIPMENT**

**FOREMOST  
VALUES**

**FASTEST  
SERVICE**

**FREE**

• World's Largest Stock of All Famous Makes . . . Your Guarantee of Quality and Long Service!

• When you deal with Newark you buy direct from the Distributor . . . Your assurance of Dealer-Low Prices!

• 3 Great Stores and warehouses in New York and Chicago to give immediate delivery over the counter, or 24-Hour Mail Order Service to All Parts of the World!

**KITS • SETS • PARTS • ACCESSORIES**

• A Penny Postcard with your name and address puts you on our mailing list for FREE Catalogs and Bulletins featuring the Greatest Buys in Radios!

20% Down — One Year to Pay for Anything Over \$75



3 GREAT STORES! 115 W. 45th St. and 212 Fulton St. in N. Y. 323 W. Madison St. in Chicago

MAIL DEPTS: 242 W. 55th St., New York 19 and 323 West Madison Street, Chicago 6, Ill.

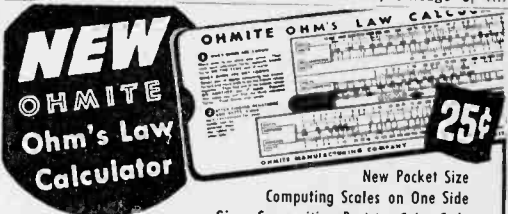

**NEW  
OHMITE  
Ohm's Law  
Calculator**

OHMITE OHM'S LAW CALCULATOR  
25¢  
New Pocket Size  
Computing Scales on One Side  
Gives Composition Resistor Color Code

**Figures Ohms, Watts, Amperes, Volts... Quickly!**

Here's a new and improved version of the famous Ohmite Calculator. Handy pocket size — 9" x 3". Solves any Ohm's Law problem with one setting of the slide. No slide rule knowledge necessary. Send 25c in coin for your Calculator.

OHMITE MFG. CO., 4972 Flournoy Street, Chicago 44, Illinois



**TELEVISION  
Loud Speakers**

**4 x 6, 5 x 7, 6 x 9, EM or PM SIZES**

**SPEAKERS** designed especially for television! Cletron's line offers the correct speaker for replacement or original equipment. See your jobber or service man.



**CLEVELAND ELECTRONICS, INC.**  
6611 EUCLID AVENUE  
CLEVELAND, OHIO



Fig. 8. An inexpensive record cabinet, purchased in a local furniture store, furnished the base for our record player cabinet.

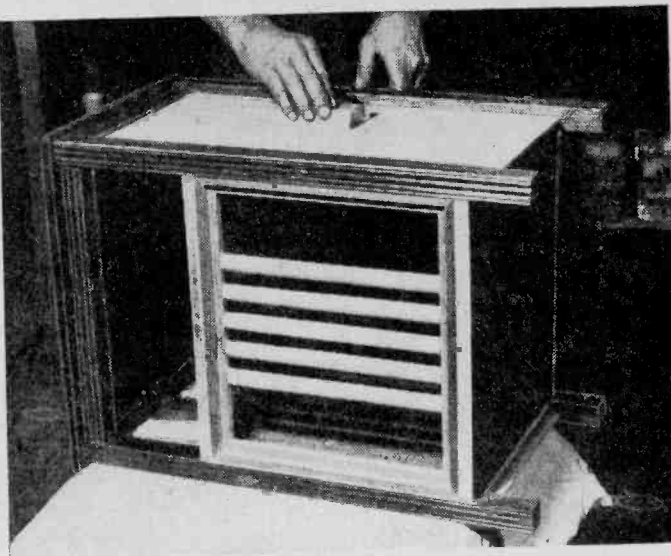
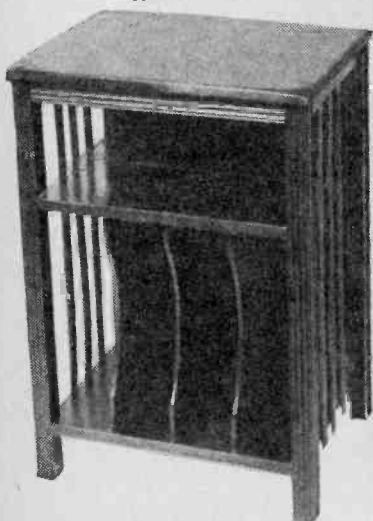
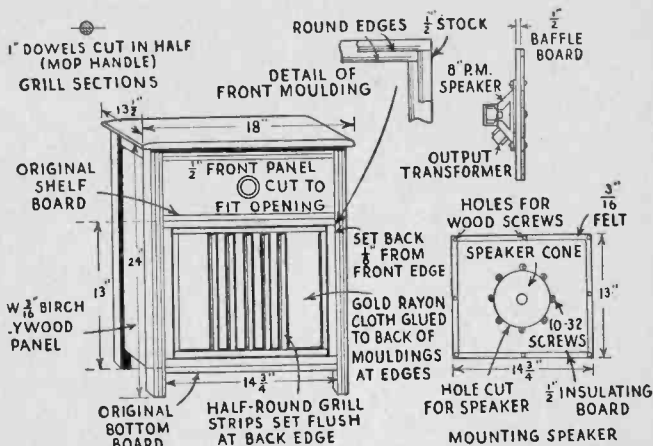

Fig. 9. The slats at both sides of the original cabinet have been replaced with 3/16 inch panels. Here they are shown being sanded. The grill, of 1/2 inch stock, and the moldings have been installed in the front of the cabinet.



Fig. 10. After the cabinet was finished in antique ivory, the parts were installed. Here we have a back view showing how the speaker and amplifier were mounted in the one-time record cabinet.



of the top compartment has been closed with a piece of plywood, but the lower chamber is best left open for the finest tone.

The drawings and Fig. 11 show how the sliding drawer is built and fitted into the top compartment. It should be carefully done so it will slide smoothly. A stop fitted inside prevents the drawer from being pulled out too far.

A view of the completed job is shown in Fig. 7-A.

cloth. It is well to glue strips of felt to the baffle around its four sides so it does not make direct contact with the wooden molding. Also, line the entire inside surface of speaker chamber with insulating board or corrugated cardboard for improved tone.

In Fig. 10, a view of the back of the cabinet is given to show the speaker in position and location of the amplifier. The back



Fig. 11. The motor-turntable-arm unit has been fitted in a shallow box built into the form of a sliding drawer in the top compartment.



Fig. 1. Completed radio-phonograph combination housed in a reconverted old radio cabinet.

# Phonograph-Radio Combination

How to add a radio and automatic record changer to your home-built record player

By HAROLD P. STRAND

**Q**UITE a number of you probably have record players which you would like to see housed in a modern or period cabinet with a radio. Of course, an automatic changer would be a must to complete this combination. This article will explain how to make this change. The author has built five of these phonographs in one form or another to date, but the one pictured in Fig. 1 has been the best of them all. It uses the same amplifier and Jensen speaker described in detail in the preceding article. But the cabinet was made over from an

## LIST OF PARTS FOR TUNER

- 1—chassis, about 12"x4"x1 $\frac{3}{4}$ " (for space in drawer pictured)
- 1—7 pin socket to fit 6F7
- 1—6F7 tube
- 1—antenna coil, air core, shielded for standard broadcast band
- 1 R.F. coil, air core, shielded
- 1—2-gang tuning condenser, about .000365 mid. or to suit coils selected
- 1—filament transformer. 115 volts to 6.3 volts
- 1—dial for standard broadcast with cable and dial lamp
- 1—1N34 fixed midget crystal detector
- 1—100,000 ohm potentiometer with knob
- 1—S.P. toggle switch
- 1—S.P. D.T. toggle switch

### Resistors

- 1—500 ohm, 1 watt
- 1—2500 ohm, 5 watt
- 1—500,000 ohm, 1 watt
- 1—100,000 ohm, 1 watt
- 1—100,000 ohm,  $\frac{1}{2}$  watt

### Capacitors

- 1— .1 600 volt
- 1— .01 600 volt
- 1— .05 600 volt
- 1— .006 mica
- 1— .0025 mica
- 1— .0002 mica

### Wire

- No. 18 stranded with light rubber and cotton insulation Shielded wire, 1 conductor, about 3 - 4 feet required.
- Misc. Materials—screws, bolts and nuts, clip terminal for grid cap, solder, etc.

old Silver Marshall highboy radio. This provides the necessary extra room for the record changer and radio.

The tall legs were cut off at the top ball turning, so it would set low on the floor. The original walnut veneer wood front, which had sliding doors, was simply rebuilt into the modern front shown. By sawing door stock to size and gluing it carefully, the four-panel matched veneer drawer front was made. Dimensions given allow use of a changer requiring not over 6 in. total height, of which there are several on the market. This drawer operates similarly to that in the cabinet which was described in the preceding article, except that it featured the use of small ball bearings as shown in drawing. These bearings are the type used in small electric motors and other machinery and cause drawer to roll in and out with smoothness and ease. A  $\frac{3}{8}$  in. square brass rod, attached to each side of drawer, operates on the ball bearings. The top pair of bearings at each side take the downward weight





# Fun with Surplus Headphones

You can make a stethoscope, hearing aid, radio, and host of other gadgets with a pair of army HS-30-F phones!

By THOMAS A. BLANCHARD  
Electronics Engineer



Nothing to tune, nothing to get out of order with peppy little set "built-into" surplus headset. Telephone dial stop provides clip-on antenna. Phone shown came from French liner "Normandie."

YOU can have a lot of fun with type HS-30-F, surplus headphones, and these receivers and their accessory parts provide the experimenter with the essentials for making a sound-powered telephone, magnetic stethoscope, detectophone, play-as-you-go radio, etc. Although no larger than a hearing aid receiver, HS-30-F units contain a powerful permanent magnet. Simply by connecting the phone cords together, you can talk into one unit, and hear your voice in the other. Sound waves cause the diaphragm to vibrate; this cuts through the permanent magnetic field and creates an E.M.F. or voltage which travels through cord to other receiver.

The earphones come attached to a spring-steel headband. For some of these stunts, it is wise to remove the phones from the headband, which

is done simply by hammering flat the flared ends of the steel band, and slipping off the individual phones. The swivel attached to the earpiece provides a means for attaching a handle to a single unit so that it may be used as a lorgnette type receiver or mike. A set of phones rigged up with handles makes an educational telephone for youngsters. The same unit is used both for talking and listening. Hook-up is shown in accompanying sketches.

The lorgnette handle is also convenient when a phone is connected through the output transformer (often included with the headset) to the radio set. It makes a dandy hearing aid for radio reception. The hand-held phone is easy to make. First, get a tea-strainer, cut off wire mesh basket, then form two remaining pieces of wire to shape shown in photo and sketch. Flatten ends with a hammer and snap into the earphone swivel!

An interesting personal radio can be quickly assembled from the original headset. While the set cannot be tuned, it will bring in strong local stations with excellent volume. Although on the novel side, it has proven very practical for late-evening listening without bothering

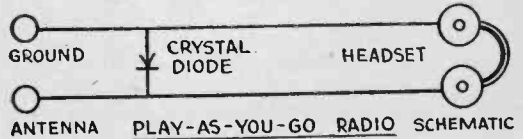

Close-up of molded rubber yoke to which diode detector, phone leads, antenna, and ground wires are attached. All wiring for radio in clear sight!

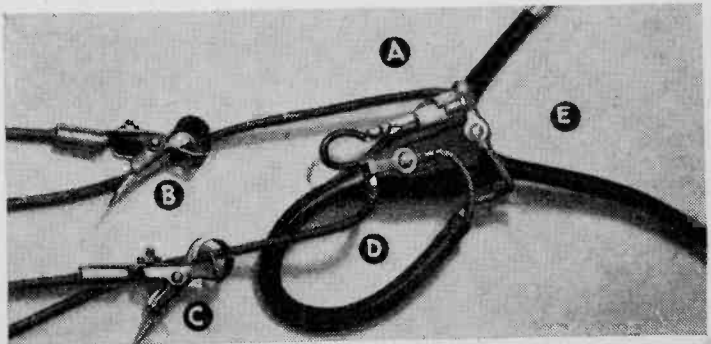
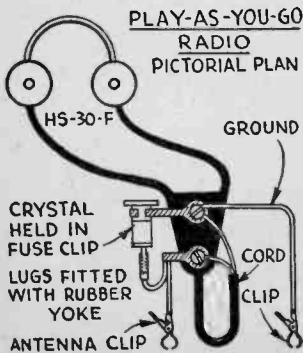



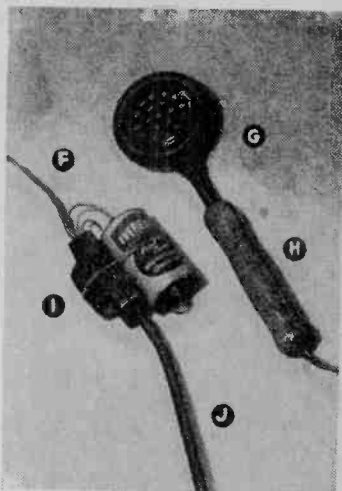
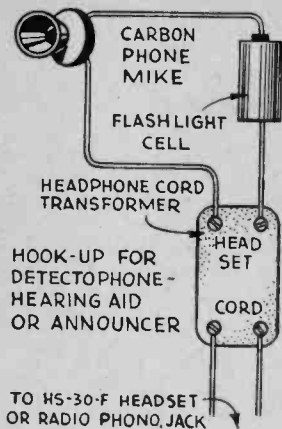
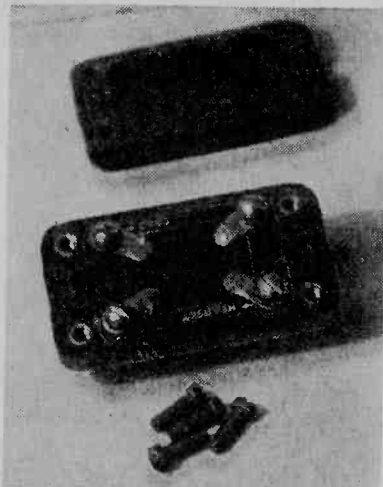

Matching transformer supplied with many HS-30-F miniature headphones. This transformer has many other interesting experimental applications.

Right. Closeup of receiver elements surrounding penny-sized disc in center: (L), magnetic unit; (M), diaphragm; (N), earplug, and (O), in the foreground, is the receiver cap.

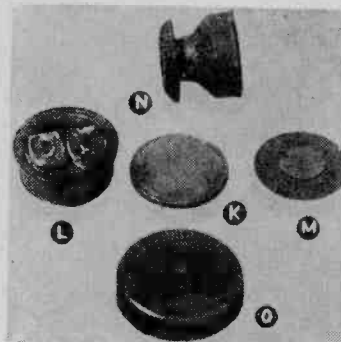

Surplus telephone transmitter fitted with handle becomes powerful detectophone and hearing aid when used with earphones and special transformer.

affair, designed to connect into phone cord just below molded rubber yoke. This transformer is necessary when headphones are used for regular radio earphone purposes. The transformer also proves to be a very efficient microphone transformer, thus making the

others. Note that the HS-30-F headset is fitted with a spring shirt clip attached to molded rubber yoke by means of two screws. Remove this clip and insert a 1/2 in. long 4-40 machine screw in the top yoke hole, to secure a small fuse clip, and one of the phone cord lugs. Then attach a soldering lug, and put remaining phone lug with another screw into lower yoke hole.

The bottom pin connection on the surplus crystal diode is a connector removed from an old tube socket. This connector has a short length of flexible wire soldered to lower yoke lug. Attached also to this lug is a length of wire provided with a spring test clip. This is the antenna. Another piece of wire with similar clip is soldered to the upper yoke terminal. This is the ground connector. After all soldered connections are complete, snap the crystal diode (surplus type, GE1N48 or Sylvania 1N34) into fuse clip.

To use the radio, attach antenna clip to finger stop on a phone dial, bell box, etc. A bed spring, window screen or similar non-grounded metal object may also be used as an aerial. In many locations, you don't have to attach the ground, though a ground will always increase the volume. The radio can be made selective to some extent by using different objects as antennae. Similar effects will be noted with grounds of various degrees of efficiency. In certain instances the phones will pick up FM broadcasts with no ground or antenna connections being made.

Now, how would you like to rig up a real detectophone? The transformer included with most of the HS-30-F headsets is a very compact

detectophone possible. When transformer cover is removed, you can see four screw terminals. Two are marked for the cord connection, the remaining are marked headset. For all usual purposes, headset would be connected to proper terminals. However, as a detectophone, earphones go to terminals marked, cord.

Next connect a single button surplus telephone transmitter to remaining transformer terminals

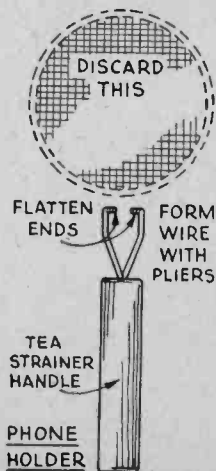

Receiver is easily equipped with this lorgnette handle fashioned from a discarded tea strainer.



## BARGAIN SPECIAL

### HS30 F PHONES

The identical phones and matching transformers shown on this and preceding pages 130 and 131. Furnished complete with shirt clip, transformer, 6 foot cord and phone plug. Brand New. Shpg. Wt. 3 lbs. No. 17A420

Per Pair..... **\$1.59**

Extra Transformer, with 6' ft. cord and PL58 phone plug. No. 14A685. Each..... **50c**

### IN34 CRYSTAL DIODE

Popular for many interesting experiments. No. 12A450. Each..... **\$1.35**

### THROAT MIKE

Use as is, or the mike buttons alone for detectophones, etc. Shpg. Wt. 1 lb. No. 17A39. PER SET..... **35c**



### T-17B MIKE

No. 18A368  
EACH..... **\$1.59**



BRAND NEW 200 ohm carbon. Has press to talk switch in handle. Sturdy good looking bakelite case. With 5 ft. rubber cord and PL68 mike plug. This and transformer above are ideal for construction article on page 131. Shpg. Wt. 1 1/2 lbs.

Mike Jack for PL68 Plug No. 18A839, Each..... **12c**



Type J 38 Key  
For Code Practice Set described on page 22. Wt. 1 1/2 lbs. No. 17A38, EACH..... **69c**

### 100 WATT

### Soldering IRON

\$7.50 Value  
No. 17B421..... **\$2.62**



Top make and quality with ceramicore heating element and 3/8" removable copper tip. Complete with cord and plug. For 110 V. AC or DC. Shpg. Wt. 1 1/2 lbs.

EXTRA COPPER TIPS  
No. 17B277, Each..... **28c**



### UTAH 9200 OHM IMPEDANCE PHONES

Highly sensitive. Adjustable head band with standard 5 1/2 ft. cord. Shpg. Wt. 1 1/2 lbs. No. 17A483  
A \$7.50 Value..... **\$2.95**

Order Direct from this Ad—Remit with order including shipping charges—over-payment promptly refunded.

FREE CATALOG—a complete listing of Everything in Radio Electronics, Television. Write for your copy if you do not already have one.



**BURSTEIN-APPLEBEE**  
1012-14 MCGEE STREET.  
KANSAS CITY 6, MISSOURI

(see drawings). To cover the short length of brass tubing which extends from the mike drill out a wooden file handle and force the brass tube into the handle. Mike cord passes through handle and tubing as shown in photo. A single flashlight cell (about 1 1/2 volts) provides ample energy to operate the detectophone efficiently. More sensitivity can be obtained by using two or three cells (3 or 4 1/2 volts) in series. Don't use more than 4 1/2 volts however, as microphone might be damaged. This detectophone may be operated over considerable distance. Solder a safety pin to back of mike case and use this same hook-up as a hearing aid. Naturally it won't be as completely efficient as a modern electronic aid.

Another stunt you can try with mike and transformer is to remove the headphones and connect a pair of wires from cord terminals on transformer to phono-pickup jack on your home radio. The volume is terrific. However, to avoid howling noises (known as feedback) have cord long enough so that you can do your broadcasting from another room.

One of the miniature earphones may be converted into a phonograph pickup. Note in photo of dismantled unit that Bakelite cap in foreground unscrews. Magnetic element shown at the left of the penny-size disc may now be lifted out of its shell and cord may be disconnected. The rubber earplug behind the center disc is snapped out of the cap and set aside. Diaphragm shown at far right in the photo was removed from magnetic element for purposes of illustration only. Don't try to pull it free of powerful magnetic field that holds it down. It bends easily, and it is best to leave it alone. Cement a good long-life juke box needle with a drop of Ambroid to center of diaphragm. Adjust needle to slight record tracking angle, and allow cement to dry



For youngsters, two way telephone system from two sets of headphones. No battery power is required.

**NOVEL PHONO PICKUP**

NEEDLE CEMENTED TO THE DIAPHRAGM

PHONE ELEMENT

SPOOL SWIVEL

MASONITE ARM

LIGHT FLEXIBLE CORD TO AMP, EARPHONE, ETC.

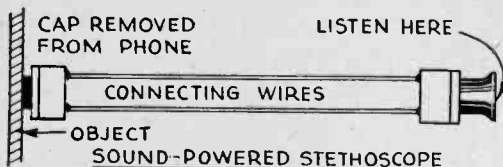
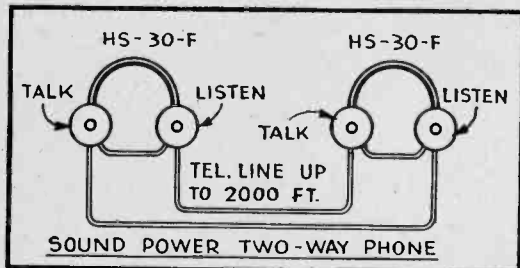

thoroughly.

Pickup arm can be fashioned from a strip of thin Masonite. A hole is drilled in one end of this strip so that earphone unit will make a tight press-fit. Attach two light flexible wires to earphone screws. Fix a swivel on opposite end of Masonite so that it functions like an ordinary phono-pickup arm. Or use an old pickup arm if you have one. There are several ways this novel pickup may be used for playing records. First, you can connect leads to other remaining miniature receiver. You can hear your favorite records with brilliant reproduction without annoying others. Or pickup may be connected into phono jack on your home set, or to a phono amplifier. In some instances, connect to set or amplifier through transformer previously mentioned, by connecting cord leads to set and head-set leads to earphone pickup.

For a stethoscope, use one receiver as a contact mike. Use other headphone and band for listening. The "pickup" phone is removed from its Bakelite case as per phono pickup instructions above. Connect both units together as you did for the sound-powered phone. The uncased receiver may be placed against musical instruments so that the diaphragm receives the vibrations. In the same manner, the open receiver unit placed on water pipes, etc., will indicate flow, leaks, etc. Other applications will suggest themselves including use on machines and automotive devices to detect friction, knock, etc. And there are many other stunts with HS-30-F headsets. By now you can think of many.

The name Van Sickle to the old-timers in radio means the place in Indiana to get their radio supplies. That's because for the past many years they have received friendly

helpful service and lowest prices on standard brands. If you are a "new-comer" in radio experimenting or an engineer unfamiliar to Indiana we invite you too to write or visit us when you can.



**VAN SICKLE**

**RADIO SUPPLY CO.**

New Location: 102 S. Penn St.  
Indianapolis, Indiana

*It's* **ONE STOP SERVICE**  
**WHEN YOU BUY FROM THE KIT-MASTER**

I can supply any part you need to build the kits in this Handbook at the lowest prices.

**WRITE FOR PARTS PRICE LIST**

SATISFACTION GUARANTEED

**DICK ROSE, 2912 Hewitt Ave., Everett 30, Wash.**

**EASY TO LEARN CODE**

It is easy and pleasant to learn or increase speed the modern way—with an **Instructograph Code Teacher**. Excellent for the beginner, or advanced student. A quick, practical and dependable method. Available tapes from beginner's alphabet to typical messages on all subjects. Speed range 5 to 40 WPM. Always ready, no QRK, beats having someone send to you.

**ENDORSED BY THOUSANDS!**

The **Instructograph Code Teacher** literally takes the place of an operator-instructor and enables anyone to learn and master code without further assistance. Thousands of successful operators have "acquired the code" with the **Instructograph System**. Write today for full particulars and convenient rental plans.



**INSTRUCTOGRAPH COMPANY**

4713 SHERIDAN ROAD, CHICAGO 40, ILLINOIS



## TINY CRYSTAL SET Built In Toy Bank

A plastic toy bank, a few odds and ends, and you have this pee-wee radio that really works

By T. A. BLANCHARD  
Electronics Engineer

**W**HILE browsing through a ten cent store, we came upon a cleverly designed plastic toy. It was a dime bank scaled down to look like a real set. The replica was complete with a pair of dummy knobs, and a speaker grill, in contrasting color, which came out to release the deposit of coins.

The originality of this toy was enough to give us the urge to convert it into a real radio. Of course, since it was only 3½ inches long, 2½ inches high, and 1¼ inches deep, we limited the design to a crystal set. (However, in the not-too-distant future, when miniature tubes, and parts are on the market, this case could house up to a 4-tube set.)

The crystal circuit is very simple, and material

requirements are few. In addition to the case, a crystal detector, a 2-inch length of 1-inch diameter cardboard tube, and some No. 30 enameled magnet wire comprise the essential materials.

The coil is wound by piercing both ends of the cardboard tube with a needle. Thread the magnet wire through one of these holes, allowing about 6 inches of wire for connections. Wind the coil form full, applying airplane cement as you go, to keep the winding in place. When reaching the end, thread the wire through the bottom hole in the tube, and allow cement to dry. The bottom end of the coil is cut off since no connection is made to the magnet wire at this end.

A strip of brass serves as the tuning arm. This strip is about ⅜ inch wide, and 2½ inches long. A hole to clear an 8/32 machine screw is drilled in one end. The opposite end is dented with a blunt punch or large nail to form a dimple in the metal arm. This dimple serves as a wiping contact as the metal tuning arm moves across the coil.

A hole is drilled in the plastic case ⅞ inch

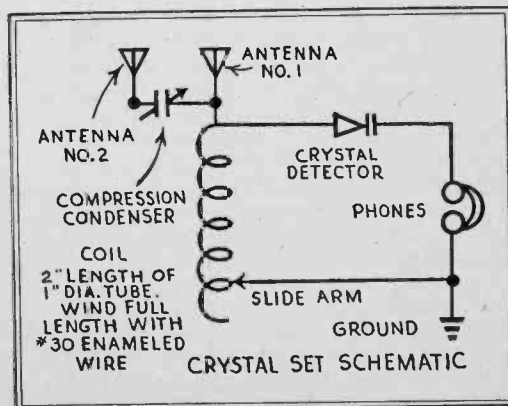

LIST OF MATERIALS

- Toy plastic bank
- Small spool No. 30 magnet wire
- 4 Fahnestock clips
- Crystal detector
- Coil form
- Miscellaneous nuts & bolts

above the righthand dummy knob. This hole is just large enough to pass the 1/2 inch long, 8/32 machine screw. Insert the screw into the arm, and solder the head fast to the brass. At the same time, solder a short length of flexible insulated wire to the screw head. Do not solder any connections after assembling parts in set as the plastic will melt.

Insert arm screw in hole, slide on a washer, nut, and then attach Bakelite knob (in this case a Burgess Battery terminal). Swing the arm back and forth, noting the swing of the arc. Now place the coil into the case and locate it so that the wiping arm will contact its surface from end to end. Before permanently mounting the coil, clean a path over the winding with fine sandpaper where the arm left its mark. This will insure positive contact when coil is permanently mounted in place with airplane cement to top and bottom of case.

A semi-fixed crystal detector is mounted along one side of the case as shown in drawings and photo. If you prefer a detector that may be adjusted from the front of the case, follow details in the insert sketch. This detector is made from odds and ends, and the "catswhisker" is a medium size sewing needle. The dummy knob is removed from the case, and pierced with a small hole. After mounting the adjustable crystal, this knob is cemented over the head of the needle to give you extra-sensitive detection and provides a set with miniature knobs—all of which actually function.

The final major constructional operation is the antenna coupling condenser. Actually this feature makes this crystal set highly selective in localities where a powerful local station drowns out everything else. In addition, this selectivity condenser may be bypassed when the set is used in remote localities; thus two antenna connections are provided.

Details on the construction of the condenser are simple enough. It is merely a compression

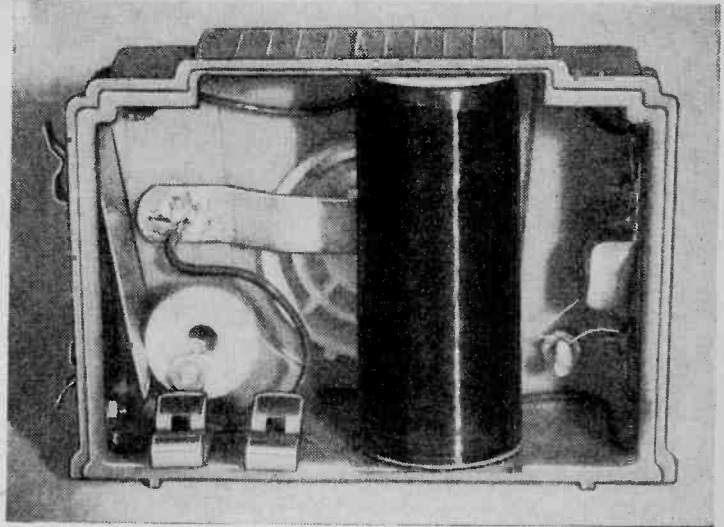

Interior view showing bank back removed and crystal set components assembled in place.

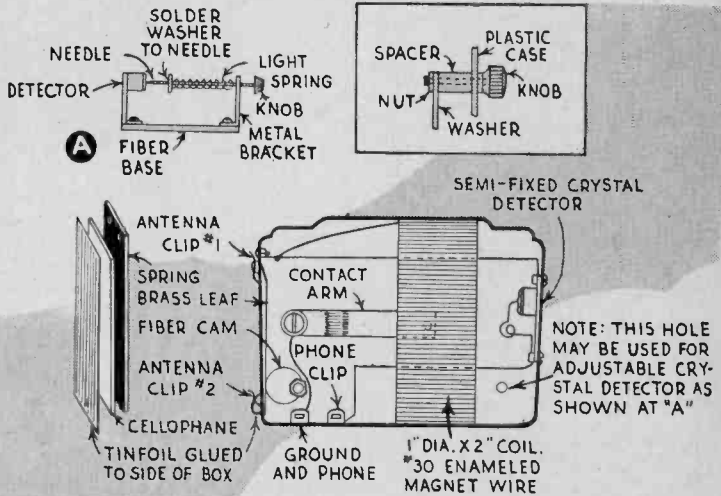

unit fashioned after the tiny "trimmer" condensers used in commercial superhet circuits, but of course with much more total capacitance.

First off, cut a piece of tinfoil 1 by 2 inches from a package of cigarettes. Don't remove the paper backing, but cement the foil, paper side down, to the wall of the plastic radio case. Drill a hole at the bottom, through plastic and foil, attach a fahnestock clip with small nut and bolt so that the clip contacts the foil.

Now cut a strip of spring brass (or shim brass from auto supplies) the same size as the foil. Also cut a piece of cellophane about 1/8 inch larger all around. The cellophane serves to insulate foil from brass.

Two small holes are drilled at one end of brass. The brass is then bent slightly near the top edge so that when mounted above the foil previously cemented into the case, it will spring away from the case. Another Fahnestock clip is

installed under either of the two mounting screws provided for the brass leaf.

The remaining dummy knob on the bank is removed, the back filed smooth and a hole just large enough for a 6-32, 1 inch long, screw to be turned into it, is drilled through the center. A drop of cement applied to the threads of the screw will permanently secure the knob against loosening.

Obtain a fiber faucet washer, drill a hole off to one side for a 6/32 screw to pass through. A washer about  $\frac{3}{4}$  inch diameter is ideal. Now insert the screw-knob through hole in plastic case, slide on a spacer and finally the fiber

washer, and lock the assembly with a nut. The result is an eccentric cam. When the knob is rotated, this cam forces the brass leaf to close against the foil. The result is a novel, but effective "fine tuning" control.

A pair of fahnestock clips are mounted to the base of the plastic cabinet for connecting headphones and ground. Viewed from rear, the left-hand clip takes one phone tip and the ground. Righthand clip takes other phone tip.

The wiping arm is used for basic tuning. After locating a station, adjust antenna condenser, the arm, and also the crystal detector so that you can obtain the maximum volume.

## FOR YOUR RADIO NOTEBOOK

### LOUDSPEAKERS: Broken Voice Coil Leads

When a voice coil lead breaks in back of the cone, in a location which cannot be reached with a soldering iron from the rear, try this: Cut a V (not a triangle) in the cone over the place where the wire is to be soldered, bend the point of the V outward, then insert your soldering iron through the opening and repair the broken wire. To complete the job and restore the cone, bend the flap back and carefully match the edges, then apply glue or cone cement to form a solid seam of cement over the cut. The cement will not appreciably affect the response of the loudspeaker.

### TUBES: Removing Lock-In Tubes

To remove a "Lock-In" or loctal tube with ease, push against the side of the tube with a thumb while pulling gently upward, so as to un-snap the locking arrangement. Sockets for these tubes have spring catches which prevent tubes from falling out during shipping or rough use in portable receivers.

### HUM: In Iron-Core Transformer

In the case of hum due to vibration of the laminations in an iron-core transformer, loosen the mounting screws so the laminations will spread apart slightly, paint the edges of the laminations with shellac or varnish, allow to dry for several hours, then tighten the mounting screws.

### BATTERIES: Misleading Tests

Dry batteries may be run-down and in need of replacement even though voltmeter measurements indicate normal battery voltages. The explanation is that batteries recover in voltage rapidly when disconnected from their load, and a voltmeter does not draw sufficient current to provide an adequate load. When normal load is

applied to a run-down battery, however, its voltage again drops rapidly and the radio set fails to work. Therefore, always test battery voltages while the batteries are connected to their normal loads, such as to a portable receiver with its switch turned on.

### SAFETY: Master Switch for Bench

If all workbench overhead lights and all outlets on the bench are run through a single master switch in a convenient location on or near the bench, the lights will serve as a reminder that current is on. Leaving the soldering iron plugged in is perhaps the most common fire hazard of the radio experimenter. If you turn off the lights by means of the master switch whenever leaving the bench, you know everything is safe. A double pole single throw switch box, with or without fuses, costs but little more than a dollar and is ideal for this purpose.

### CONDENSERS: Electrolytics in Parallel

An extra 10-mfd., 450-volt electrolytic condenser connected in parallel with the input filter condenser of a radio receiver will often reduce or eliminate an annoying power hum. Condenser values add when in parallel, so you are adding 10 mfd. to whatever capacity value is already in the set. Be sure to observe correct polarity of connections—plus to plus, and minus to minus. The black lead is usually minus.

### SOLDERING: A Hint on Better Work

When using a non-corrosive soldering paste flux for radio work, first warm the joint slightly with the soldering iron, then apply the paste with a piece of wire. The small amount of flux which melts on the joint is entirely adequate. Excessive flux spreads to adjacent insulation, causing leakage.



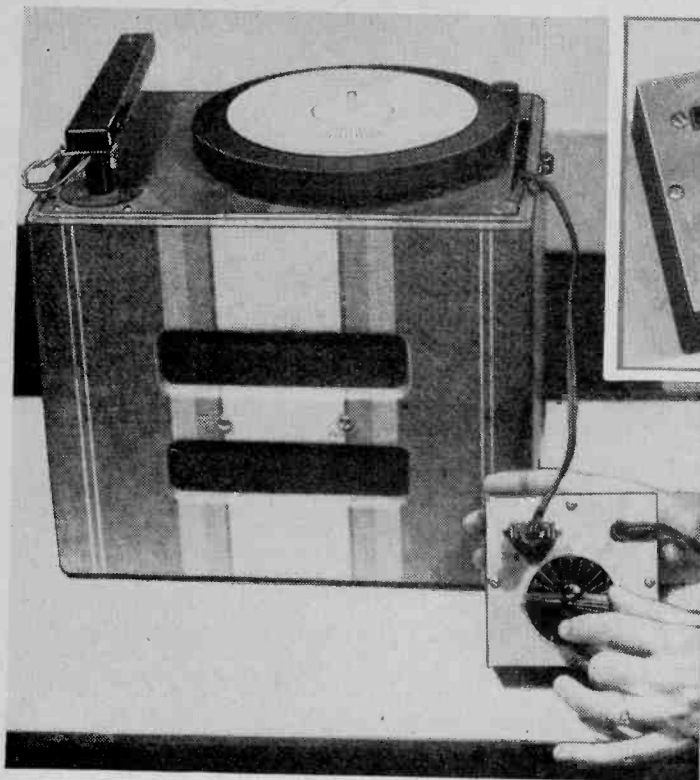

Record player is plugged into control outlet at left. The speed is then adjusted by turning the knob.

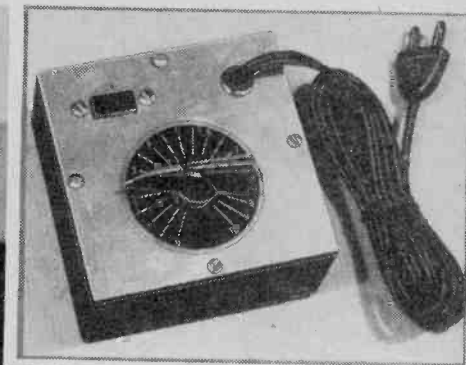

Here's the compact speed control which allows you to play  $33\frac{1}{3}$  rpm records.

## Speed Control *for* Record Players

With this unit you can play the new Microgroove records and  $33\frac{1}{3}$  rpm transcriptions on your present record player turntable

By T. A. BLANCHARD  
Electronics Engineer

**T**HE old-fashioned spring-wound phonograph had its disadvantages, but it did possess a feature modern record fans would welcome—speed control. Practically all modern phonograph motors operate at a fixed speed of 78 rpm. When playing records made by the big name manufacturers, their precision recording facilities insure playback at the proper speed. However, a host of small recording firms are coming up out of nowhere with hits. Often, however, these records are improperly recorded on the master. Subsequently the record you buy plays too fast.

With the motor speed control described here,

you will not only be able to regulate erratic records, but also use your 78 rpm motor for playing  $33\frac{1}{3}$  rpm transcriptions and the ultra-new Columbia LP Microgroove records. These LP records are probably the greatest improvement in recorded music since the invention of electronic reproducers. Where the conventional 10 in. record plays for about 3 minutes, the new LP 10 in. record gives you almost 15 minutes entertainment on one side. The speed control is also useful in smoothing out homemade disc recordings. Excessive friction from the cutting head often slows up the turntable during the making of a record. Thus when you play the record back, the turntable is running at its proper speed of 78 rpm instead of possibly 65 rpm—the actual cutting speed.

The control is housed in a standard metal box such as those stocked by all radio suppliers. The box measures 4 in. square and 2 in. deep. The 4 x 4 in. panel is laid out according to plan and then fitted with a 1000 ohm, 25 watt wire-wound rheostat and small rectangular female outlet. Power is delivered to control box by 6 ft. rubber cordset connected through grommet at right of outlet. After wiring has been completed, panel may be replaced, and speed control is made ready for use simply by connecting cordset to 115 volt supply and plugging phonograph motor into outlet on control panel. Be certain, however, that motor circuit *alone* connects to speed control. In some instances, phono motor and phono amplifier are connected to a common extension cord. If this is the case,

disconnect motor leads and fit with a short length of fixture cord and a separate plug.

While record speed can be adjusted to suit your ear simply by turning rheostat knob, there are many instances where a precise speed adjustment may be desired. In this case, a stroboscope is used. This

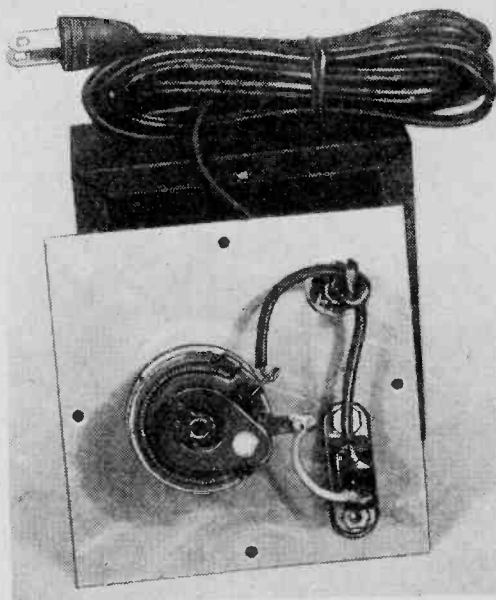
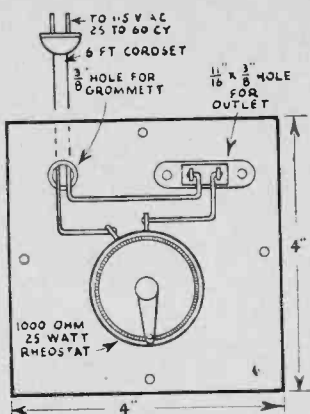

Bottom view of phono-motor control. Rheostat is in series with power cord and outlet at lower right.

current found in Canada and the U.S. West Coast where bulbs seem to "flutter" when viewed steadily. Fluorescent lamps reveal this action even at 60 cycles because, unlike Mazda lamps, they employ no filament once started. Mazda lamps momentarily retain light after power is off due to residual action of hot filament.

To use the Stroboscope, cut out the accompanying illustration of it, paste it on cardboard, and place it over the phonograph record label. While the record is playing, adjust the speed control until the proper circle appears to stand still. Going from inside to the outside circles, the inside circle indicates 78 rpm on 25 or 50 cycle current; the second circle indicates 78 rpm for 60 cycle current; the third circle stops motion at  $33\frac{1}{3}$  rpm, 25 or 50 cycle current; and the outside circle indicates  $33\frac{1}{2}$  rpm at 60 cycles. Because of needle friction, true speed is always determined with a record playing. This is apparent especially when low cost motors slowed down to  $33\frac{1}{2}$  rpm are used. First adjust the motor control to stop the  $33\frac{1}{3}$  rpm circle, with the record playing, of course. Now without touching speed control, remove pick-up and note that  $33\frac{1}{3}$  circle is no longer standing still.

This speed control works with 99% of all motors in common use today since they are the "squirrel-cage" induction type. The cheaper phono motors may lack sufficient torque to play transcriptions unless the pick-up is counterbalanced to reduce needle friction. However, this does not apply with the new LP Microgroove records because a featherweight pick-up has been designed for them. If you visit local radio stations, you can probably get a few old transcriptions gratis for experimental purposes. As the

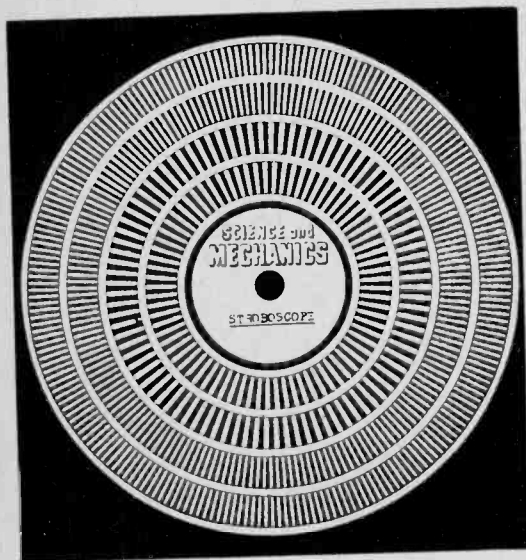

is the same device used in broadcasting stations and recording studios. The stroboscope was invented in the mid 80's by Joseph Plateau, a French physicist. He discovered that equidistant slits cut in a disc, would cause moving objects to appear stationary when the spinning disc was placed between the eye and object in motion. A fast-moving object requires a fast moving stroboscope disc and few slots, while a slow-moving object requires many slots in a slow-moving stroboscope. The rotation of the stroboscope is in direct relation with the moving object in order to obtain illusion that object is standing still.

By using black and white spaces on a cardboard disc, black and white divisions will appear to stand still when viewed under incandescent or fluorescent light from an alternating current source, once synchronized with the 60, 50 or 25 cycle pulse. Because the human eye responds very slowly to light changes, we are not aware that a Mazda bulb flashes on and off 60 times each second. This action is visible with 25 cycle

# More New Ideas For Projects You Can Build



Here are twelve of our most popular projects. Each Craft Print gives complete dimensions and all necessary construction details. By using these plans, you can build projects that have been pre-tested and you know they will prove highly satisfactory. Order by number.

No. 4—**MOTOR SCOOTER** .....\$0.25

Made entirely from used parts. Has cruising speed of 20 miles per hour and does better than 80 miles on a gallon of gasoline.

No. 50—"TRAIL SCOUT" CABIN TRAILER ..... .25

Another streamlined cabin trailer ideal for hunting, fishing or travel. 12½ ft. long, 6 ft. high, plywood construction. Roomy.

No. 68—**GARDEN WINDMILL** ..... .25

Patterned after old Dutch windmills, yet has modern touch that will brighten any garden. Stands 6 ft. high. Can be wired for lighting.

No. 84—**FOLDING CHAIR** ..... .25

About the most comfortable chair anyone could desire. Folds into a very compact space.

No. 86—**WORKBENCH FOR CRAFTSMEN** ..... .25

Large worktable, drawers, shelves, slides and many other unique features make this an ideal workbench.

No. 89—**SPORTSMAN'S CABIN TRAILER** ..... .25

This 12 ft. cabin trailer has space for a "daveno" bed, dinette, icebox, stove, sink, galley, etc. All plywood construction. Detailed plans show how to build it.

No. 108—**POWERING YOUR LAWN MOWER** ... .25

Complete instructions for adding a power unit to your lawn mower, using mostly used or salvage materials.

No. 118—**BIRDS AND ANIMALS FOR LAWN** ... .25

Full size patterns of 11 birds and animals, including rooster, parrot, turtle, dog, goose, pelican, etc. Color scheme shows how to paint each cutout.

No. 118A—**MINIATURE PEOPLE FOR LAWN** ... .25

Seven original designs for soldier, drum major, sprinkling girl, Dutch boy and girl, etc. Color scheme given for each figure.

No. 134—**ANIMATED GRASSHOPPER** ..... .25

A toy that will thrill any child. Grasshopper jumps as you pull it. Easily made with hand tools.

No. 140—**BUILDING A POWER LAWN MOWER** . .25

By using easily obtained scrap materials, you can build a first-class lawn mower to do your heavy work. Full details given.

No. 149—**FARM TRACTOR FROM AUTO PARTS**. 1.00

This powerful, all-purpose farm tractor is made from old auto parts. Handles plowing, cultivating, hauling and heavy farm work. Complete working drawings and instruction booklet explains all construction details.



No. 89—Cabin Trailer

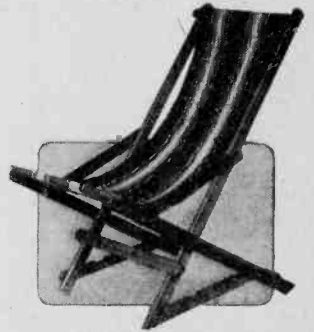

No. 84—Folding Chair

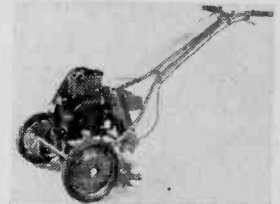

No. 108—Power Lawn Mower

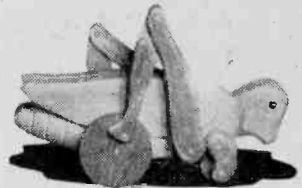

No. 134—Animated Grasshopper



No. 68—Garden Windmill



No. 118A—Lawn Cutouts

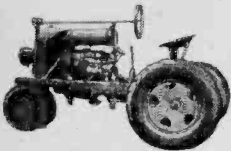

No. 149—Farm Tractor

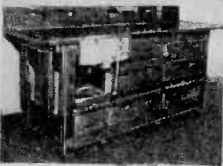

No. 86—Craft Workbench



No. 4—Motor Scooter

## MAIL YOUR ORDER NOW

SCIENCE AND MECHANICS  
450 East Ohio Street, Dept. R-1, Chicago, Ill.

Enclosed is \$.....for which please send me Craft Prints Nos.....

NAME.....

ADDRESS.....

CITY.....ZONE.....STATE.....

regular phono pickup arm is too short for these discs, purchase a replacement crystal cartridge, and make a lightweight pickup arm from aluminum or plastic, arranging it so the end beyond the pivot or fulcrum can be weighted with iron washers secured by a bolt. The better quality phono motor known as the "heavy duty" type,

will usually rotate at 33 $\frac{1}{3}$  rpm without counterbalancing. In fact, our own tests were made on a low cost motor without the weighted pickup arm. However, we cannot guarantee this for all cheap motors. The simplicity of this speed control, and the few components required, make this project a really useful accessory for record fans.

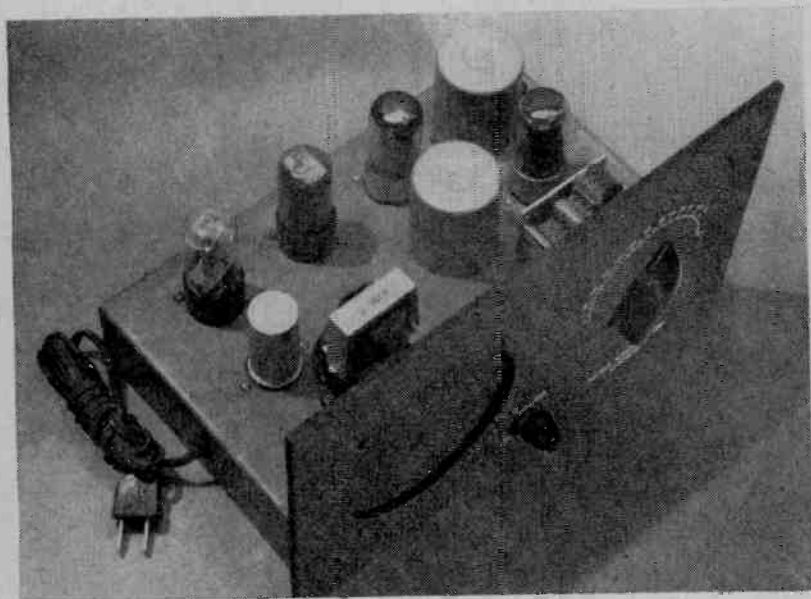

## Constructing a 4 Tube TRF Receiver

This receiver is especially designed for high quality reception using a minimum number of parts

By N. J. RUBENS

Engineering Division  
Allied Radio Corporation

**T**HIS 4-tube TRF Receiver is a highly efficient and sensitive radio receiver, and is easy to build and operate. TRF (tuned radio frequency) circuits, because of their rather broad tuning characteristics, give high quality in standard broadcast signal reception. This set, with 2 gang-tuned circuits, provides adequate selectivity for the broadcast bands. It operates on either AC or

DC lines, with no ballast tubes or line cord resistors needed. An antenna of only about 50 feet is sufficient for this receiver. No ground is necessary as the set is grounded through the ordinary house lighting circuit.

The tube complement was selected to give the best possible performance with the least number of parts. The 12SK7GT tube is the RF amplifier. Volume control is effected in this stage by varying the bias on the tube, and at the same time, shunting the antenna. The 12SJ7GT tube is an infinite impedance detector. This type detector does not load the tuned circuit, thus improving overall selectivity. It is one of the best types available anywhere for handling any signal with minimum distortion. The 50L6GT tube is the

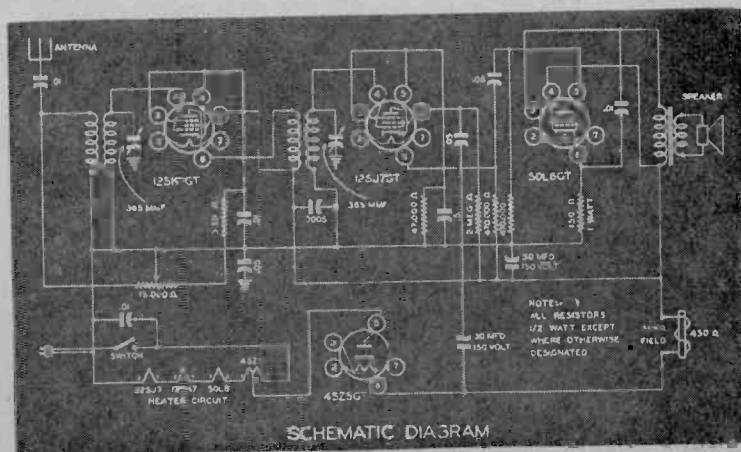

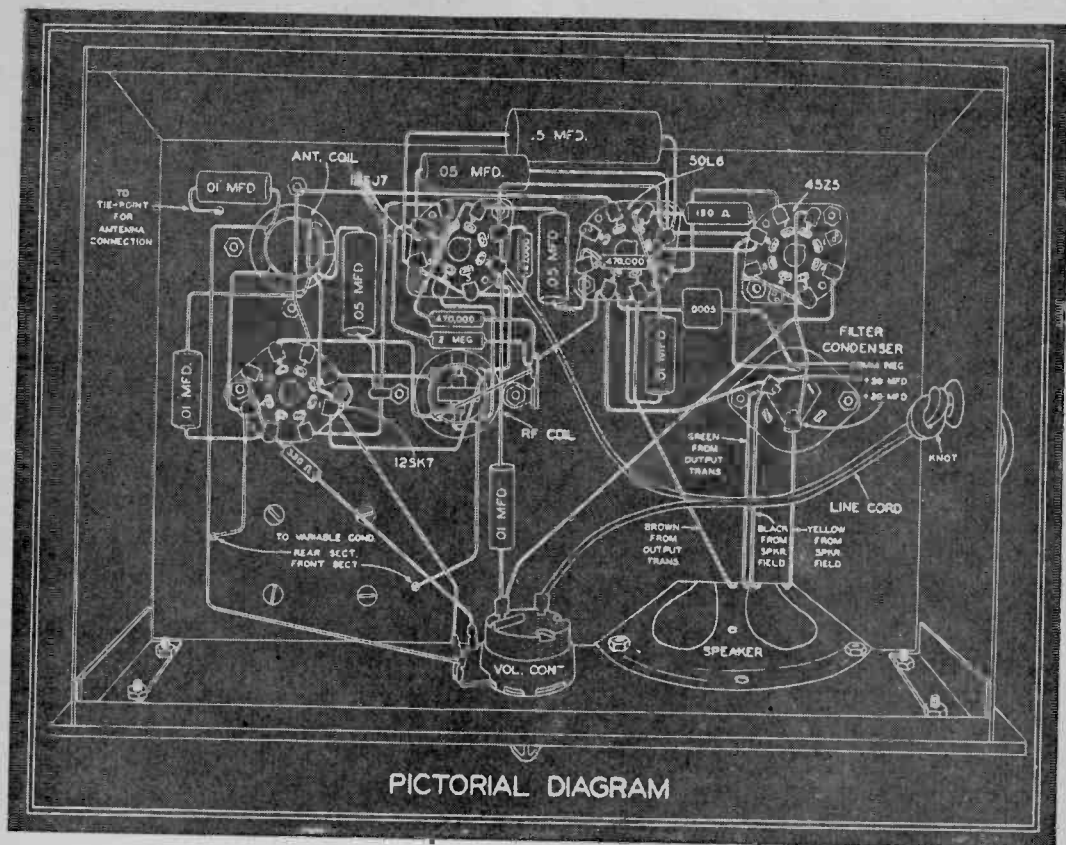

beam power output stage, supplying 2 watts of power to the speaker transformer. Inverse feedback is introduced by the use of a .01 mfd. condenser between plate and cathodes, and by leaving the 150 ohm cathode resistor un-bypassed. Inverse feedback reduces distortion and hum, and is used in all modern amplifier circuits. The 45Z5GT tube is a half wave rectifier representing the power supply section of the circuit. The total of 60 mfd. in the filter condenser plus the filter choke action of the speaker coil provides unusually good filtering.

### Study Before Assembling

Look the diagrams over carefully before beginning construction. A few minutes of preliminary study, plus careful mounting and wiring, will save trouble-shooting later. So take your time and plan the job out thoroughly.

Use of an already punched and formed chassis makes assembly simple. First mount all of the parts except the small tubular condensers and carbon resistors. The condensers and resistors are supported by their own pigtail leads at the time of wiring. Mount the sockets from the

### LIST OF PARTS REQUIRED

- |  |   |
|--|---|
| 1 125K7GT Tube                             | 1 Output transformer to match 50L6GT and speaker  |
| 1 125J7GT Tube                             | 1 5" dynamic speaker, with 450 ohm field  |
| 1 50L6GT Tube                              | 1 370 mmf. 2-gang tuning condenser  |
| 1 45Z5GT Tube                              | 1 punched and formed cadmium plated metal chassis, 7" x 11" x 2" (Allied Radio Corp. No. 55-530)    |
| 1 330 ohm, 1/2 W. carbon resistor          | 1 calibrated, black crackle finished masonite front panel, 7" x 12" (Allied Radio Corp. No. 55-531) |
| 1 47,000 ohm, 1/2 W. carbon resistor       | 4 Octal tube sockets  |
| 2 470,000 ohm, 1/2 W. carbon resistors     | 1 1/4" volume control knob  |
| 1 2 megohm, 1/2 W. carbon resistor         | 1 1/2" pointer knob   |
| 1 150 ohm, 1 W carbon resistor             | 1 Grill cloth for speaker   |
| 4 .01 mfd. 400 V. paper tubular condensers | 2 1 terminal mounting strips  |
| 3 .05 mfd. 400 V. paper tubular condensers | 1 Line cord with plug   |
| 1 .5 mfd. 400 V. paper tubular condenser   | 1 Antenna coil, shielded  |
| 1 .0005 mfd. mica condenser                | 1 R.F. coil, shielded   |
| 1 30-30 mfd. 150 V. electrolytic condenser | Miscellaneous hardware, wire, etc.  |
| 1 15,000 ohm potentiometer                 |   |
| 1 Switch for potentiometer                 |   |



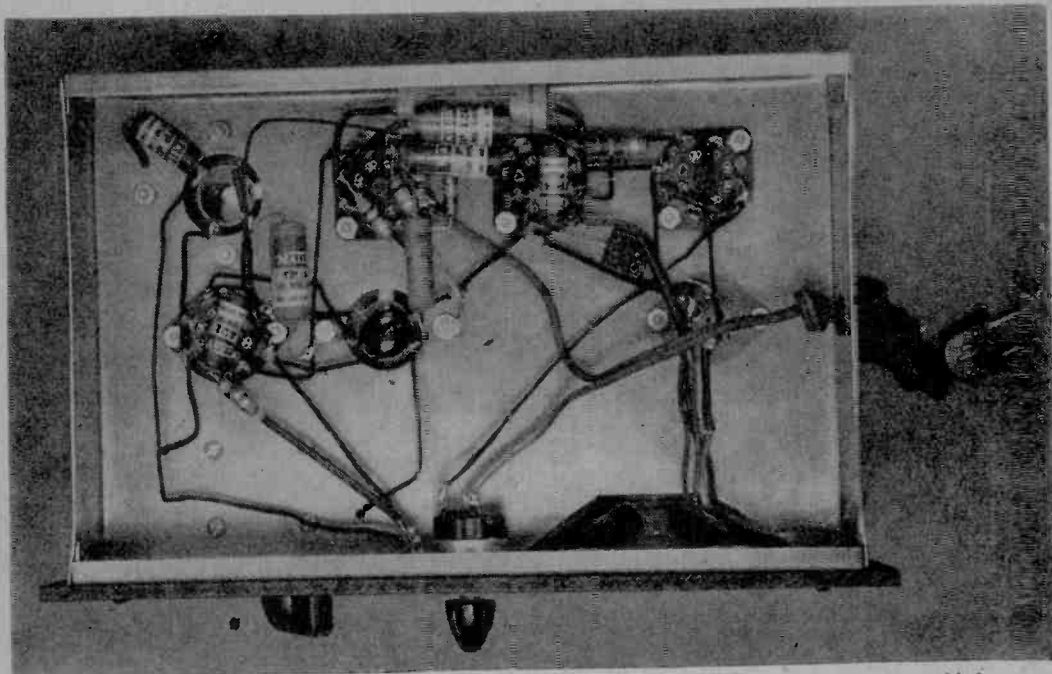

Underneath view of the receiver showing the various components after they have been assembled.

under side of the chassis, with the tube guide slots facing in the direction shown in the pictorial diagram. Mount the tuning condenser with the four large screws, shown in the lower left hand corner of the pictorial diagram. Place the grill cloth over the speaker opening in the masonite front panel, and bolt the speaker in place. Attach the panel to the chassis. In installing the antenna and RF coils be sure that the wooden insulating spacers (inside the shielding cans) are in the positions shown in the pictorial diagram, so that the terminal lugs will be in proper position for correct wiring. Fasten the filter condenser to it. The condenser is held in place by inserting it into the insulating wafer, and twisting the three small protruding ears, as shown in the accompanying pictorial diagram.

### Make Wiring Direct

You may follow either the schematic or the pictorial diagram in wiring the receiver. The pictorial is preferred for the use of the beginner, as it shows the actual location of every part, wire, and connecting point. Make all connections as short and direct as possible, keeping the wires close to the chassis. Cut off excess pigtail leads from the small condensers and resistors to make a neat compact job.



Looking at the assembled receiver from the rear.

All connections must be soldered. Use a hot, well tinned soldering iron, and rosin core solder. Avoid the use of acid core solder or acid flux to prevent corrosion. The wire must first be securely hooked into the terminal to which it is to be connected. Preheat by applying the hot



iron for a few seconds until the connections are hot enough to flow the solder. Then apply just enough solder to fill the crevices and make a secure connection. Remove the iron, but do not move the wires until the solder has set.

Work slowly, checking off connections on the diagram as they are actually made—this will help prevent omission of connections.

If you live in or near a large city, a short antenna of about 50 feet will operate well. However, if you are not near a station, a longer antenna may be necessary. The antenna should be as high as possible and well insulated.

When the receiver is complete, connect the antenna, and insert the line cord plug into the house power socket. If your power supply is direct current (DC) it may be necessary to reverse the plug, as the receiver will only operate when the polarity is correct. When using alternating current (AC), the receiver will operate regardless of plug position, but reversing the plug may minimize any hum or noise.

You should be able to tune in several stations immediately. To bring the stations in at peak strength, with greater selectivity, and at the proper frequency settings on the dial, a simple adjustment at the variable condenser is required. Tune the receiver to a station at the low frequency end of the broadcast band. Loosen the set screw of the tuning knob and adjust the tuning pointer to read the correct frequency for that station. Then tune the receiver to the highest frequency station you can hear, adjust the small trimmers on the side of the variable condenser with a screwdriver until the station comes in at its loudest volume. Check to see if the tuning pointer indicates the proper frequency for the station you are listening to. If it does not, set the dial at the correct frequency and adjust each of the trimmer screws on the variable condenser until the station is again brought in at its peak. To bring the station to a lower frequency on the dial, turn the trimmer screws counter-clockwise. To move the station higher, turn the screws clockwise. Be sure that you maintain peak performance at all times. Careful adjustment in this manner will bring stations in at proper dial setting, and give best possible performance. For best quality reproduction always tune the stations in "on the nose" and make adjustments with volume control.

**A Tube Will Hold Screws**

• If you have difficulties inserting screws in small space, you can solve this problem by putting a piece of rubber tubing on the end of the screwdriver. The tubing will hold the screw firmly and securely in place as you work the screw in.

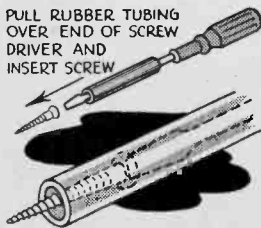

PULL RUBBER TUBING OVER END OF SCREW DRIVER AND INSERT SCREW

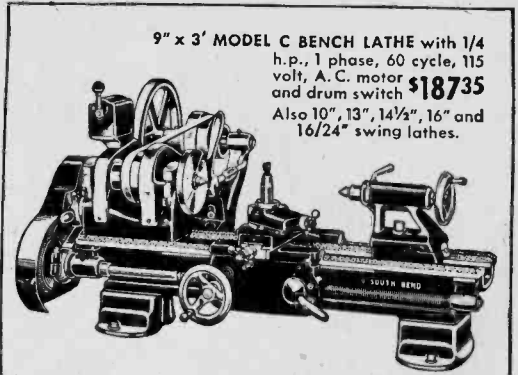

9" x 3' MODEL C BENCH LATHE with 1/4 h.p., 1 phase, 60 cycle, 115 volt, A. C. motor and drum switch **\$18735**  
Also 10", 13", 14 1/2", 16" and 16 1/4" swing lathes.

**SOUTH BEND MACHINE TOOLS**

Make Tough Jobs Easy



**14" DRILL PRESS**

Bench model with chuck, switch and 1/3 h.p., 1 phase, 60 cycle, 115 volt, A.C. motor . \$129.30.  
Floor Model . . . . . \$144.30.

You can broaden the scope of your experimental work with South Bend Machine Tools. They'll make it possible to produce special tuning units, chassis assemblies and other equipment to your exact requirements. You won't have to depend on outside sources for custom work—and you'll save a lot of time and effort.

South Bend Machine Tools are designed for fine industrial work. They are used by many radio manufacturers for precision manufacturing and experimental work. They bring you extreme accuracy, dependable service and greater value for your money. Write now for literature, specify machines you are interested in.

All prices are f. o. b. factory. Time Payment Plan is available.

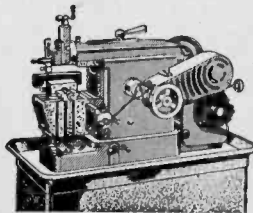

**7" BENCH SHAPER**

with vise; 1/3 h.p., 1 ph., 60 cy., 115 volt, A.C. motor; and switch, \$456.30  
Steel Stand (extra), \$125.

**SOUTH BEND LATHE WORKS**

Building Better Tools Since 1906  
446 E. MADISON ST., SOUTH BEND 22, INDIANA



# Modern Crystal Radio Receiver



Fig. 1

That old stand-by, the crystal set, becomes a modern construction project in this article

By ADOLPH SUCHY

**R**ADIO receiving sets have passed through a series of stages of development which has resulted in the modern, multi-tube complex radio with short wave, F.M., television and phonograph reproduction. Of all of these stages, perhaps the most intriguing has been the crystal receiver. Because of ease of construction and inexpensive price it has been a favorite with beginners.

It must be recognized, however, that the crystal set has limitations. A good antenna not less than 75 feet long must be used if satisfactory results are to be expected. Usually there is insufficient volume for loud speaker operation and headphones must be used. Under ordinary conditions the range is about 25 miles, but crystal sets have been known to receive stations much further away than 25 miles.

Until recently the standard crystal detector was

---



---

### Parts List

- 1 piece 18 gauge aluminum 4"x5½"
  - 1 .000365 microfarad (or 365 mmf.) variable condenser single gang. Cardwell
  - 1 antenna coil Meissner #14-1004
  - 1 1N21 or 1N34 crystal detector (Sylvania)
  - 1 double phone tip jack
  - 1 double screw type terminal strip
  - 1 single terminal lug
  - 2 soldering lugs
  - 1 .001 tubular fixed condenser, any voltage
  - 1 3" dial calibrated 0-100
  - 1 hardwood baseboard 4"x5½"
  - 5 ft. push-back hook-up wire
  - Rosin core solder, wood screws
- 
- 

difficult to adjust and when adjusted, remained sensitive for short periods only. Finding a sensitive spot with the "cat-whisker" was an arduous task and that spot was lost if so much as a fly would walk across the table. There have been several fixed crystals sold from time to time but these were insensitive and usually quite expensive.

As a result of the research done on Radar during the war, fixed crystals have been developed that are both sensitive and cheap. These crystals have as the sensitive material a mineral called "Germanium" which is highly sensitive at radio frequencies and affords not only a good detector for our present project but will also be used by manufacturers in F.M. receivers and in many other ways.

Figure 1 illustrates a radio receiver using the crystal described above. It has been used by the author in a suburb of New York City and with a 75 foot antenna eight broadcast stations were received clearly and with comfortable volume on the phones. A longer antenna would undoubtedly increase the volume

and possibly bring in another station or two. The set is mounted on an aluminum panel with a hardwood baseboard. The panel was purchased from a dealer in scrap metal for five cents and the base was salvaged from the cellar woodbin. The rest of the parts on the list of materials were purchased from a local radio parts distributor. While it is not necessary to duplicate the parts shown in the photos exactly, be sure that the electrical characteristics closely resemble those specified.

**The Panel**

The panel is cut from a piece of 18 gauge aluminum and is drilled according to the drawing in Fig. 3. The mounting holes for the condenser have been omitted as these will vary with the type of condenser used. The two holes at the bottom of the panel are for the wood screws that attach the panel to the wooden base. The large hole near the center is for the shaft of the variable condenser.

**The Baseboard**

On the illustrated set, the baseboard was made from oak and cut to the same size as the panel.

**The Variable Condenser**

The single gang variable condenser shown in the picture has a maximum capacity of .000365 mfd. (or 365 mmf.). Any condenser having approximately this capacity may be used. The constructor may have difficulty in buying a single gang condenser or may have in his junk box a double or triple gang condenser of this capacity. Such a condenser may be substituted if only one of the sections is used. The frame of the condenser is connected to the rotor in the condenser. Connections to the rotor may be made directly to the frame.

**The Coil**

The constructor may make his own coil but it is strongly recommended that a manufactured coil be used. The results from a manufactured coil are uniformly good and dependable. The coil used was a Meissner Antenna Coil No. 14-1004. Any broadcast antenna coil

such as Miller or Carron may be substituted with equally satisfactory results. Accompanying the coil and packed with it is a chart designating the terminal connections of the coil. Be sure that this chart is not mislaid because it will be used in wiring the set.

**Assembly**

1. Drill all holes for mounting the variable condenser before any assembly is attempted.
2. Attach the panel to the baseboard by two No. 5 round head wood screws.
3. Mount the variable condenser.
4. Mount the twin phone tip jack at the rear center of the baseboard. This strip is mounted on metal pillars which raise it from the board and through which pass the round head screws fastening it to the board.
5. Mount the Ant.-Gnd. terminal strip on the left hand side of the baseboard close to the edge.
6. Mount the antenna coil. This may be mounted either on the variable condenser as is illustrated, or by wood screw to the baseboard.
7. Mount the single terminal lug as shown in the illustration.

**Wiring**

1. The complete wiring diagram is shown in

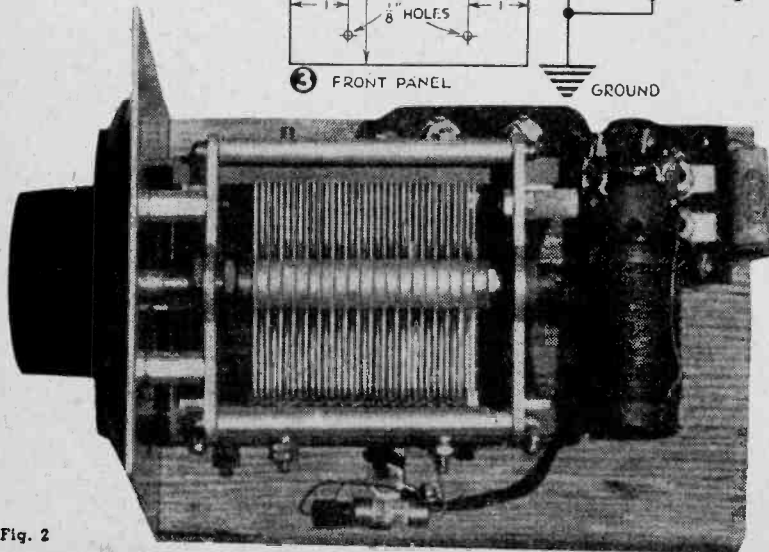
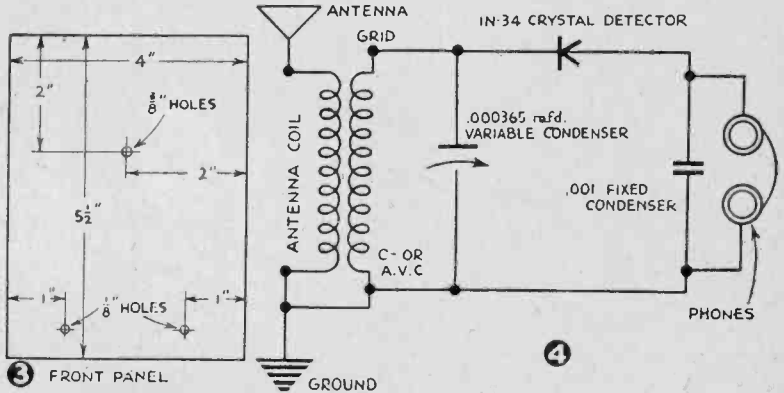

Fig. 2

Fig. 4. This should be carefully studied before wiring is started.

2. Solder a wire to the "A" or Antenna lug on the coil. The other end of this wire is connected to the Antenna post.
3. From the "G" or ground lug of the coil a wire is run to the ground post.
4. From the ground post a wire is run to the frame of the variable condenser.
5. From the frame of the variable condenser a

wire is run to the "A.V.C." or grid return lug of the coil. Another wire is run from this point to one terminal of the phone jack strip.

6. A wire is run from the stator (the stationary plates) of the variable condenser to the "G" or Grid terminal of the coil. The "plus" of the crystal detector is now wired to the same terminal.

7. The "minus" of the crystal is now connected to the single terminal lug and the other connection of the phone terminal strip is wired to this point.

8. The .001 condenser is now wired to both lugs of the phone tip jack; one side of the .001 condenser is securely wired to each lug of the phone tip jack.

Operation

A 75 to 100 foot antenna is now connected to the antenna post of the set. A water pipe or piece of pipe driven six or seven feet into moist soil is used as a ground. Be sure that all rust and corrosion are removed from the pipe before attaching the ground clamp to it. A dial is attached to the variable condenser shaft and phones are plugged into the phone tip jack.

Rotate the dial. If the wiring has been correctly done, the antenna of sufficient length and all parts good, the constructor will be rewarded for his efforts. The range of this set is limited to under fifty miles so don't expect to receive far distant stations with it.

# Heathkit TEST EQUIPMENT

*Build YOUR OWN*



**Heathkit AUDIO GEN. KIT \$34.50**



**Heathkit TUBE CHECKER KIT \$29.50**



**Heathkit 5" OSCILLOSCOPE KIT \$39.50**



**Heathkit TELEVISION GENERATOR KIT \$39.50**



**Heathkit SIGNAL TRACER KIT \$19.50**



**Heathkit BATTERY ELIMINATOR KIT \$22.50**



**Heathkit CONDENSER CHECKER KIT \$19.50**



**Heathkit ELECTRONIC SWITCH KIT \$34.50**



**NEW Heathkit IMPEDANCE BRIDGE SET \$69.50**



**Heathkit R.F. SIGNAL GEN. KIT \$19.50**



**Heathkit VACUUM TUBE VOLTMETER KIT \$24.50**



**NEW Heathkit HAND TESTER KIT \$13.50**

Heathkits are beautiful factory engineered quality service instruments supplied unassembled. The builder not only saves the assembly labor cost but learns a great deal about the construction and features of the instrument. This knowledge aids materially in the use and maintenance of the equipment. Heathkits are ideal for and used by leading universities and schools throughout the United States. Each kit is complete with cabinet, 110V 60 cycle transformer (except Hand-Tester), all tubes, coils assembled and calibrated, panel already printed, chassis all punched, formed and plated, every part supplied. Each kit is provided with detailed instruction manual for assembly and use. Heathkits provide the perfect solution to the problem of affording complete service equipment on a limited budget. The basic three instruments — an Oscilloscope, Vacuum Tube Voltmeter and Signal Generator can be purchased in Heathkits for \$83.50, about the cost of a factory built VTVM alone. Write for complete catalog.

## HEATH COMPANY

BENTON HARBOR, 23 MICHIGAN

EXPORT DEPARTMENT  
13 EAST 40TH STREET  
NEW YORK 16, N.Y.  
CABLE — ARLAB — N.Y.

# How to Get Three Speeds from a Two Speed PHONO MOTOR

By ARTHUR TRAUFFER



Fig. 1. The centering disc for Victor 45 rpm records. The writer turned his disc from cold-rolled steel.

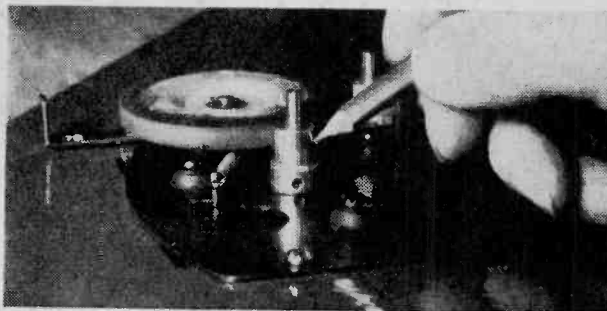

Fig. 2. The works of the General Industries Model-DR dual-speed phono motor. Pencil points to the 78 rpm diameter on removable aluminum collar over motor shaft.

IF YOU own a General Industries Model-DR dual-speed (78 and 33 rpm) phono motor which plays both standard discs and Columbia LP's, you can, by a simple operation, convert it to play in addition the new 45 rpm RCA-Victor discs. An inspection of the motor (Dwg. 1) reveals that the 78 rpm part of the motor shaft is a removable aluminum collar held by a spline type set-screw. When set-screw is loosened and collar removed you will find the motor shaft measures about .3115 in. and gives turntable a speed of about 58 rpm. Pack cotton around motor shaft to keep metal shavings out of motor bearings, and while motor is running, file shaft down to about .263 in. or just enough to give exactly 45 rpm. (Dwg. 2). Now the table speed can be shifted from 45 to 33 rpm instead of from 78 to 33 as formerly and the aluminum collar can be put back

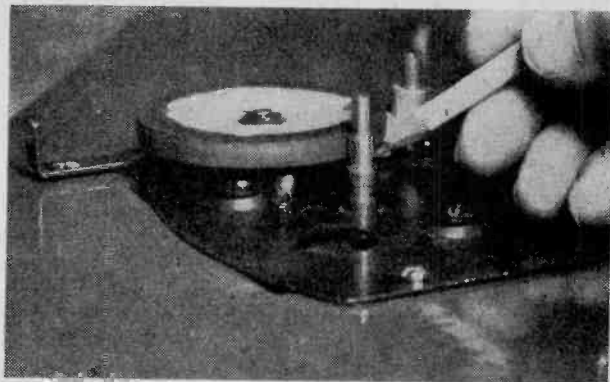

Fig. 3. The 78 rpm aluminum collar has been removed by loosening spline set-screw. Pencil points to part of motor shaft that has been filed down to .263 in. or just enough to give exactly 45 rpm. Aluminum collar can be put back for 78 rpm.

on the motor shaft to play 78 rpm discs.

Use a new or clean file to file shaft to 45 rpm. The motor shaft turns in a counter clockwise direction; move the file against the direction of turn. Take a little at a time off the shaft and test for speed each time to prevent obtaining a turntable speed below 45 rpm. Turn centering disc on a lathe from cold-rolled steel, fiber, plastic, or even hardwood (Dwg. 3).

### The Super Brake

A small electric motor, spinning 16,000 times a minute, is halted in six turns by a new magnetic brake—equivalent to stopping a mile-a-minute automobile in 2.73 feet.

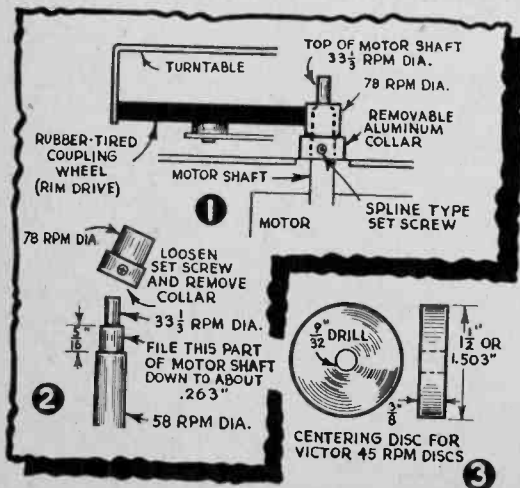

# RADIO and ELECTRICAL SOLDERING

**T**HE technique of radio soldering is not difficult if the craftsman will first study the fundamental practices involved. First, one must consider what solder is and why and how it is made to adhere to metals.

Solder is an alloy used as a bonding agent between two metal surfaces. Solder, to be more specific, is usually composed of tin and lead in various proportions.

Before the war most soft solder was composed of half tin and half lead, commonly known as 50-50 sol-



(Vega Aircraft Co. Photo)

The only complete and up-to-the-minute exposition on radio and electrical soldering ever published

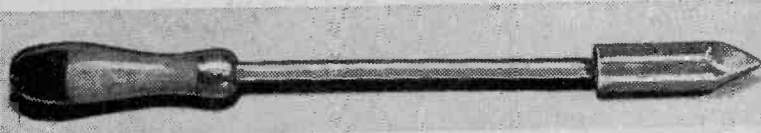

Fig. 1. The conventional soldering "iron."

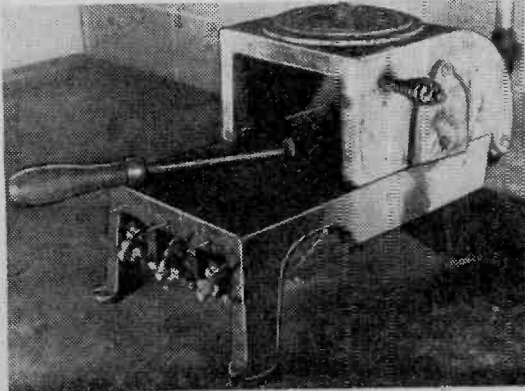

Fig. 2. A gas furnace may be used effectively for heating the soldering iron.

der or "Half and Half." Because most of our tin was imported from the Far East, it was necessary to apply conservation measures so as not to deplete our stock pile. Consequently the govern-

ment ordered reductions in the tin content of solder to not more than 20 per cent. Today tin is still scarce, so that 45-55 solder (45% tin and 55% lead) is the best normally obtainable for radio work, but you can do good radio work even with 40-60 solder.

Solder that is composed of equal parts of tin and lead will melt completely at about 415° F. This temperature is lower than the melting point of either metal. Tin will melt at 450° F. and lead will melt at 621° F.)



Soldering is the process of joining together metal surfaces through the alloying of the various metals present and causing a surface fusion when the surfaces have been properly conditioned and the joint raised to the proper temperature. This explanation will be discussed in more detail under preparation of joints, the soldering iron, solders, fluxes, and the actual soldering technique.



### Tools and Equipment for Soldering

The tools and equipment necessary for good soldering vary according to the type of work. The main governing factor is the size and quantity of work to be turned out. In radio and model work the tools are necessarily small, while in work such as the tinsmith might do larger equipment is required.

Because soldering is performed by application of heat, some tool or piece of equipment is necessary to supply

Fig. 3. Heating a conventional soldering iron with a blowtorch.

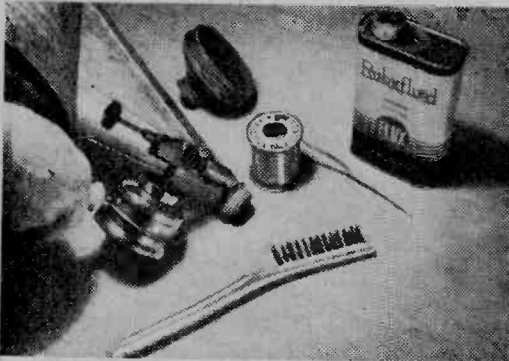

Fig. 4. This blowtorch with the soldering copper attachment can be used as a soldering iron.

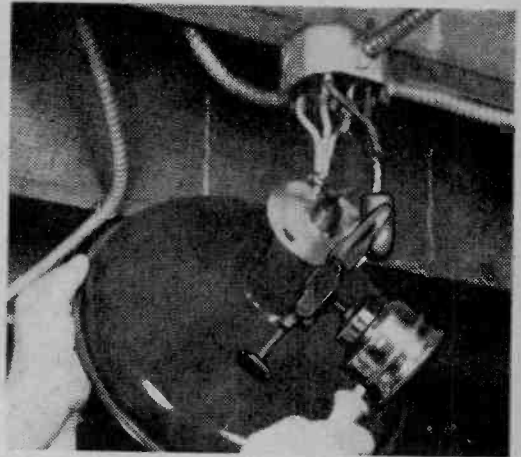

Fig. 5. By attaching a non-spill dip pot the soldering connections may be made without regard to position.

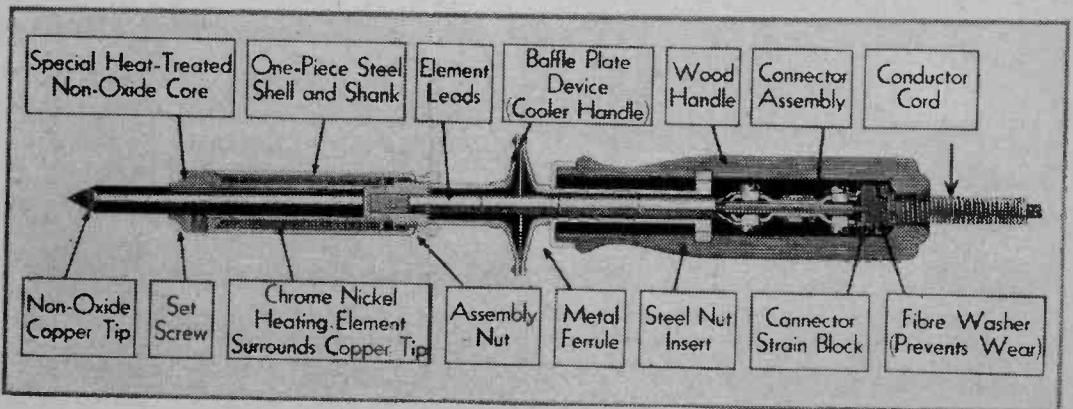
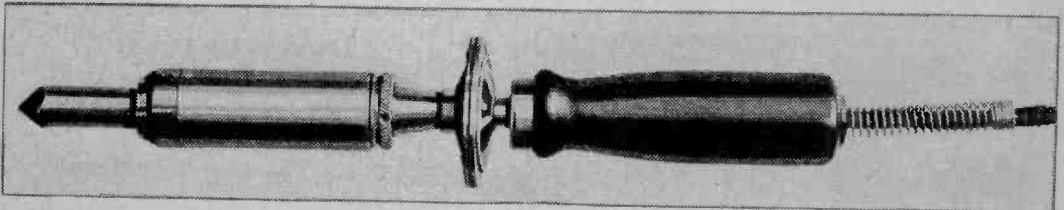

Fig. 6. Electric soldering iron and cross-section view of it.

heat. For radio work an electric soldering iron is the first choice, and the ordinary soldering copper is used only when electric power is not available.

An ordinary soldering copper, conventionally called an "iron" (Fig. 1), is inexpensive, and excellent work will be the result if properly used. It lends itself to work of repair nature better than it does to production, because it loses its heat quickly. To overcome this some operators use two irons, heating one while the other is in use. The heating of the conventional soldering iron may be either by use of a gas furnace (Fig. 2) or a blowtorch (Fig. 3). A new iron recently placed on the market supplies the heat directly to the soldering head by a gas flame. Another example of this type of gas heated soldering tip and melting pot attachment is shown in Figs. 4 and 5. In this type of torch the necessary pressure is generated within the torch itself. It is compact and very convenient when working in confined quarters or for overhead operations.

The electric iron (Fig. 6) consists of a wire wound resistance unit in the body which generates heat, which in turn is delivered through a conductor to the copper tip.

One company that manufactures electric soldering irons makes a special armor clad tip which is essentially a regular copper tip with a relatively thin sheath of special metal

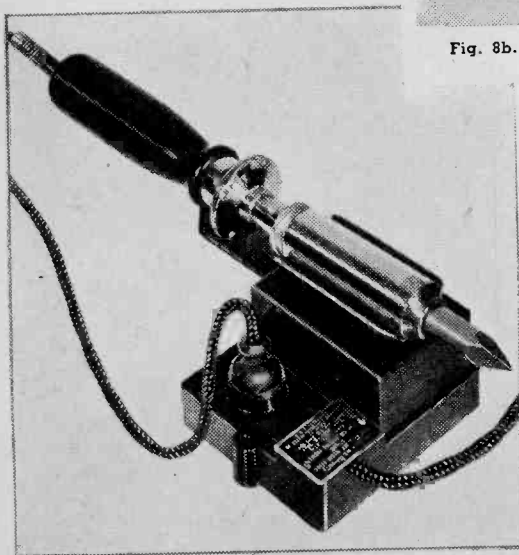

Fig. 9. The temperature regulating stand keeps the iron ready for instant use.

### HOW TO SELECT THE PROPER IRON FOR THE JOB

Work to be Done	Choice of Tip Diameter	Approximate Watts of Electric Iron	Weight Size of Non-Electric Iron
Very light radio, telephone, electric appliance, fuses, fine instruments, and for home use.	$\frac{1}{8}$ "- $\frac{3}{16}$ "	44-52	$\frac{1}{2}$ lb. (1 lb. per pr.)
Medium soldering on switchboards, telephones, radios, electric appliances, and light Mfg.	$\frac{3}{8}$ "- $\frac{1}{2}$ "	60-70	1 lb. (2 lbs. per pr.)
Fast soldering on radios, telephones, electrical appliances, jewelry, etc. For light medium jobs in home, factory and schools.	$\frac{5}{8}$ "- $\frac{3}{4}$ "	85-100	$1\frac{1}{2}$ lbs. (3 lbs. per pr.)

Fig. 7.

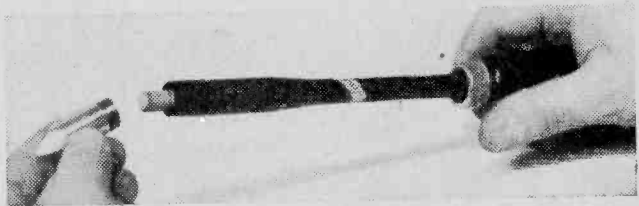

Fig. 8a. In this iron the heating unit extends into the copper tip, creating a faster heating of the iron.

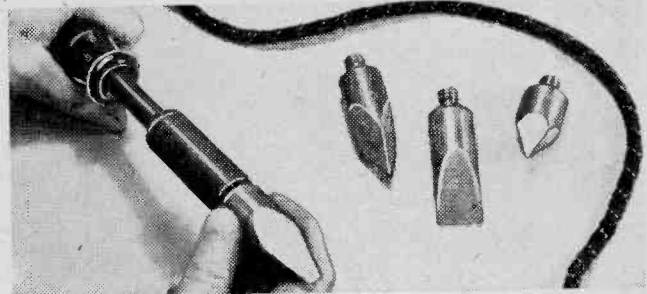

Fig. 8b. Interchangeable screw-type points for an electric iron.

bonded to the surface which eliminates excessive wear, oxidation, pitting, and amalgamation of the copper with the solder. The life of armor clad tips is reported to be from three to ten times greater than all copper tips, depending on the amount of wear or friction in the process involved in their use.

Armored tips retain their original shape for their entire life, filing being unnecessary. They are readily retinned with the use of a good flux and solder. This special metal sheath makes no noticeable difference in the transmission of the full heat of the iron. These tips can be had in a variety of shapes and sizes and are extensively used in production soldering as they do not require frequent dressing for reconditioning or replacement.

The selection of the proper size soldering iron depends to a large extent upon the type of work being done. Fig. 7 may serve as a guide in the approximate selection of the soldering iron to use

Special Soldering Equipment

Fig. 9 shows a temperature regulating stand used with an electric soldering iron. It is a thermostatically controlled device for the regulation of the temperature of an electric soldering iron while at rest. When the iron is placed on this stand, it is maintained at working temperature and ready for instant use. The temperature is adjustable from low to full working temperature as desired. A rheostat can be hooked into the circuit to function in similar manner to control the heat of the iron while it is in use as well as idle.

Another type of heat control allows constant temperature regulation at all times. There are no thermostats. A flip of the switch and the iron is ready for use in a few moments. A variable resistor allows individual temperature control to meet the requirements for each operation.

The Thermo-Grip (Fig. 11) is an electrically heated plier type of soldering tool. It operates on a resistance heating principle and attachments are available for practically any soldering job.

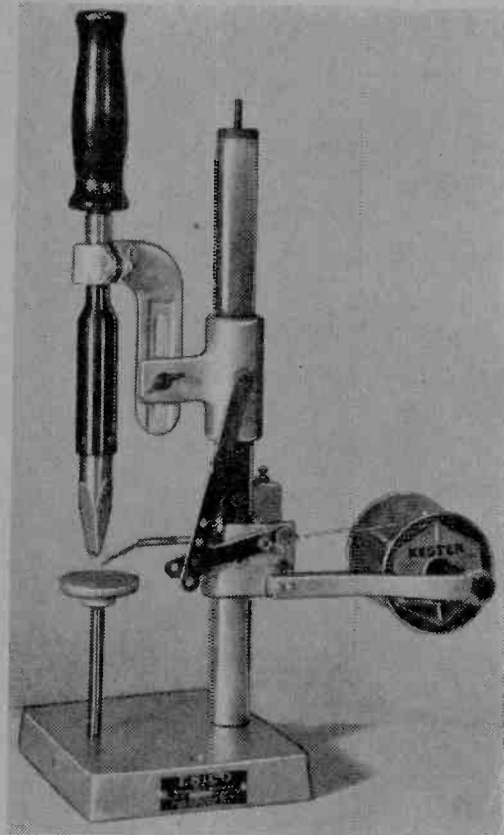

Fig. 10. The soldering machine is handy and speeds up production work.

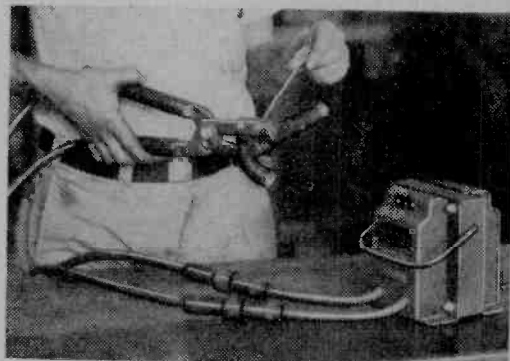

Fig. 11. Thermo-grip has instantaneous heating and is concentrated on the spot being soldered.

whether it be an electric or conventional iron.

Shapes and sizes of interchangeable screw type points for use on electric irons are shown in the photographs (Figs. 8a and 8b).

MELTING POINTS OF METALS AND SOLDERS

Metals	Degrees Fahrenheit	Degrees Centigrade
Aluminum	1216	658
Antimony	1166	630
Bismuth	514	270
Copper	1981	1083
Gold	1945	1063
Lead	621	327
Silver	1762	961
Tin	454	232
Zinc	786	419

ALLOYS OF SOLDER

Melting points only approximate  
Tin content mentioned first

Alloys	Degrees Fahrenheit	Degrees Centigrade
25/75	50	260
30/70	48	249
35/65	47	243
40/60	46	238
45/55	44	227
50/50	41	213
55/45	39	199
60/40	37	188
63/37	35	181

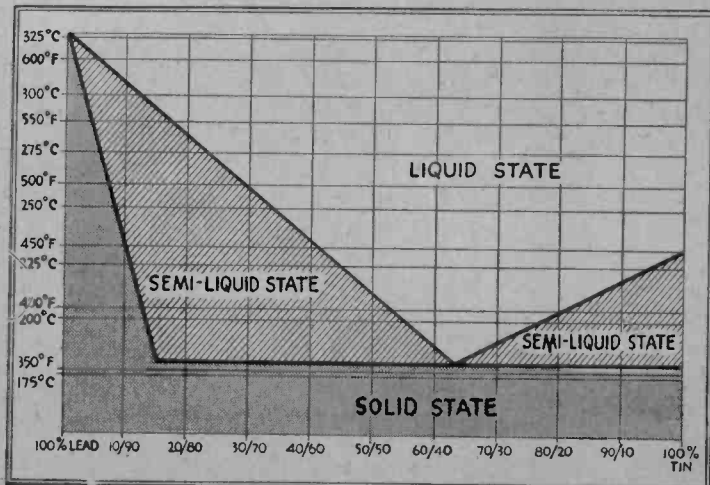

Fig. 12. Chart of melting points. First number on bottom scale is percentage tin; second is percentage lead. Note that solder with about 63% tin melts fastest and cools the fastest because it melts at a lower temperature.

Fig. 13. Support the electric iron on a block of wood when cleaning the point.

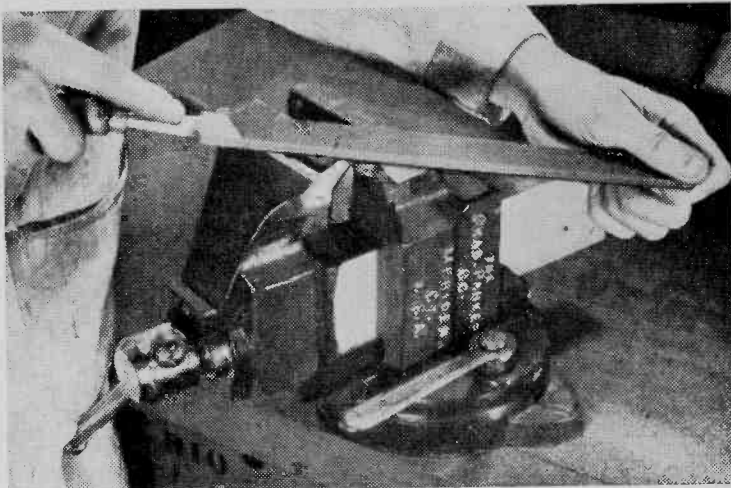
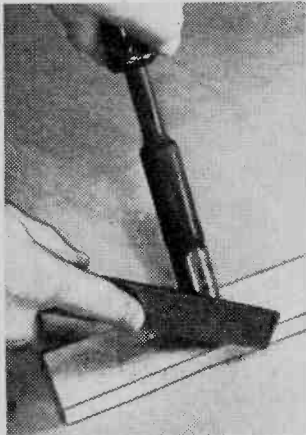

Fig. 14. A non-electric iron may be held in a vise.

The heating is almost instantaneous and is concentrated on the spot being soldered. Either soft or silver solders may be used on work ranging from delicate instruments up to heavy bars and lugs. This type of soldering tool works equally as well with low tin content solders having high melting points as it does with 50-50 solder.

### Common Solders

Tin and lead, when combined in various proportions, give certain characteristics to the alloy and are the controlling factor in solder selection for a specific purpose. In making a choice of solder for a given job one must consider the peculiar behavior of its physical character when it is heated and when it is cold. A high tin content in solder makes it crystalline, hard and easy to fracture, but it will still be ductile. The solder with a low tin content has a lower tensile strength but an increased ductility.

The selection of the proper alloy of solder to use is dependent upon the following:

1. Melting point.
2. Strength.
3. Bright or dull appearance.
4. Rapidity of solidifying.

The higher the percentage of tin the lower the melting point (up to 63 per cent tin, when the melting point rises from 358° to 450° F.). Also, the more tin, the harder, stronger, brighter and cleaner will be the joint. Naturally the high tin content solders cost more and are difficult to obtain.

While 50-50 solder is generally used for radio work, one containing approximately 63% tin and 37% lead is the ideal one to work with. As noted in Fig. 12, this alloy is at the eutectic point, which means that the two metals act as a solid and a liquid at approximately the same temperature, in this case about 375° F. This eliminates the mushy state common to other alloying percentages while cooling off. Also, you'll generally

find that the higher tin content makes a bright, smooth, neat joint.

### Soldering Fluxes

If one should attempt to apply plain solder to an uncleaned piece of metal, the melted solder would roll off without adhering. This, of course, is to be expected because the metal usually contains a film of dirt, grease, or metal oxide which prevents the molecules of solder from alloying with those of the metal to be joined. Even when the surface is cleaned by filing or scraping, one has difficulty in joining the work satisfactorily, as metal oxides form very rapidly upon application of heat.

If we are to apply solder successfully to the joint, it is necessary for these oxides to be removed as fast as they form on the heated metal. This is accomplished by supplying a flux along with the solder.

The flux should be suited to the job as some fluxes have a corrosive action which eventually eats away the joint and causes failure, especially on electrical and radio work. The most used radio flux is rosin.

**Rosin flux**—Rosin is a solidified material when at room temperature, but liquid when heated. It can be had in lump or powdered form or dissolved in a spirit solvent. It is also available as the center of "rosin core" solder. As rosin is non-corrosive and non-conductive, it is best for tinned metals, electrical connections, radio, telephones, and connections in fine instruments, tinware, lead, and copper.

To deliver the heat to the work rapidly and satisfactorily, it is necessary that all faces on the copper point of the soldering iron be covered with solder. The process of applying solder to this point is termed "tinning." Unless this tip is kept in a tinned condition, a non-conducting oxide or crust will form that will prevent the flow of heat to the work. To tin the iron:

Heat it first to a temperature comparable to the actual soldering operation, then, with a flat bastard file, preferably a new one, wire brush, or other suitable means clean the point of all scale and pits. Usually the operator will support the tip of the soldering iron on a brick, block of wood, or solid object while performing this operation (Fig. 13). Do not squeeze an electric iron in a vise. Whenever the tip has become burned or whenever it has worn out of shape, it must be filed or ground back in shape. A non-electric iron may be held in a vise without damage. (Fig. 14).

With the surface clean, the iron is ready for tinning. Should the iron get cold while preparing the tip, reheating and a light polishing of the tip may be necessary to remove the slight oxide formed by reheating. Now quickly rub rosin-core solder over the entire cleaned tip of the iron. Wipe off surplus solder with a cloth.

Never use sal ammoniac to clean or tin the iron when doing electrical or radio work as some of this material may get into the various vital parts of the assembly and cause trouble because of its high corrosive and conductive properties.

#### Preparation of the Work

The metals to be soldered must be clean and bright, free from grease, dirt or oxide and preferably tinned (coated with pure tin or solder). Cleaning may be accomplished with a file, scraper, wire brush, sand or emery paper or

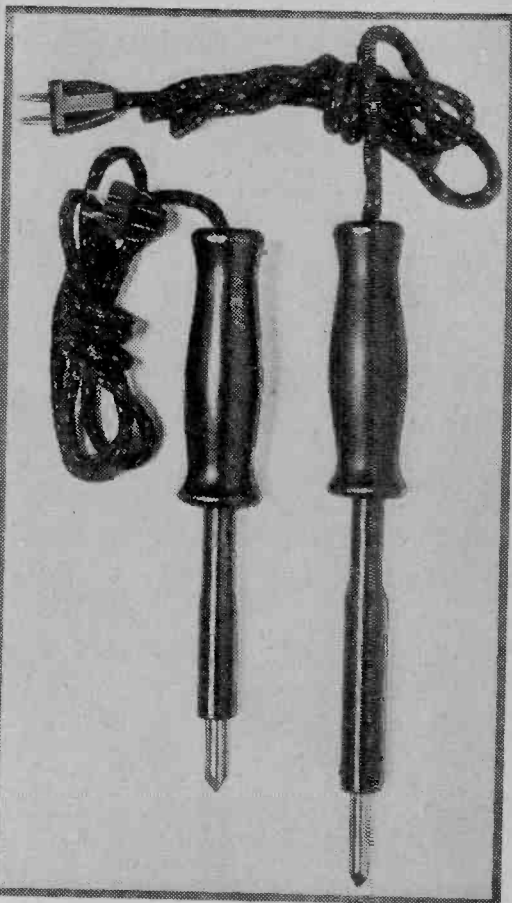

Fig. 16. A small electric soldering iron for radio.

cloth, steel wool, or by a grinding wheel. The metal should be cleaned for a reasonable area beyond that to be soldered. If the parts are oily and greasy they should first be cleaned with a solvent.

#### Radio Soldering

The soldering iron for radio work should be light in weight, with a small pointed copper tip and a rating of 50 to 100 watts if the electric type is used. One is shown in Fig. 16.

#### Use of Soldering Guns

Another special type of soldering tool that is well suited for radio repair work is the Weller soldering gun. It takes only about five seconds to get up to working heat after the trigger switch is pulled, which eliminates the need for keeping a soldering iron plugged in all day long just so it will be ready for use when needed. The wire tip can be bent to any shape needed for getting into cramped quarters, and requires no filing or tinning. A lamp bulb mounted between the wires shines directly on the work when the trigger is pulled, for working in dark corners of a chassis. The two-heat model provides extra heat

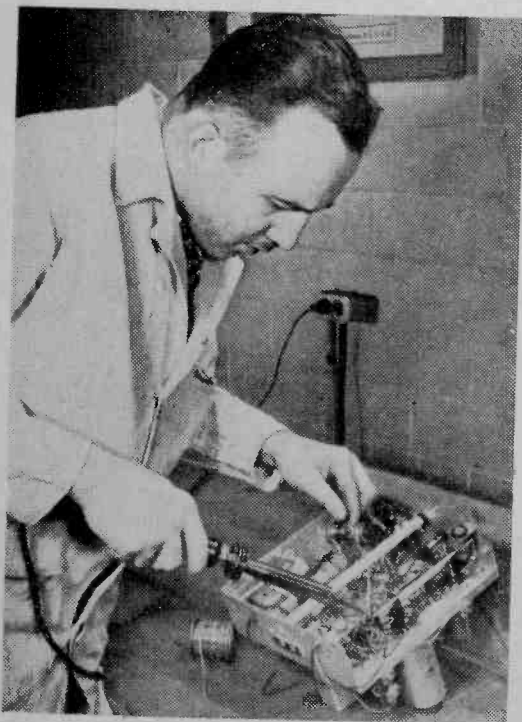

Fig. 15. The proper equipment and materials will help you do a neat job in radio work.



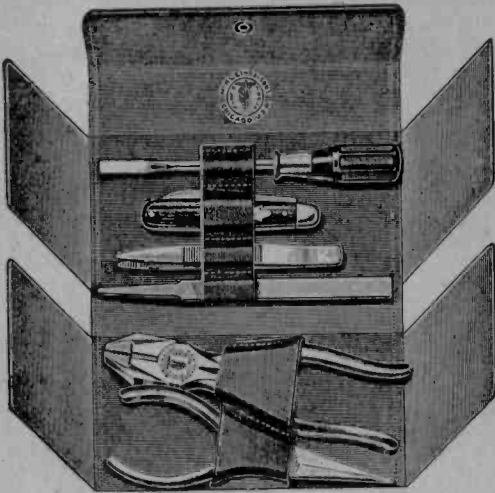

Fig. 17. A kit of tools for electrical soldering.

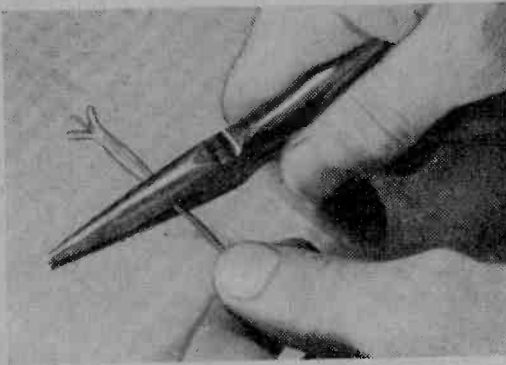

Fig. 18. Mashing insulation with long-nose pliers.

when the trigger is pulled all the way back, for soldering larger objects.

Use the gun just like a regular soldering iron. Hold the wire tip against one side of the joint, pull the trigger, apply a dab of solder between the tip and the joint to aid heat transfer, then apply solder to the other side of the joint.

Besides the iron, only a few additional tools are needed for this work. These include a pair of long-nose pliers, a pair of side-cutting pliers, a pocket knife, and a flat metal-cutting file about seven inches long. A complete kit is pictured in Fig. 17. A piece of sandpaper often comes in handy, and of course a supply of rosin-flux solder is needed. No other type of solder should be considered for radio work.

If surplus solder accumulates on a soldering iron during radio work, it is best to discard it either by wiping it off with a cloth or shaking it off with a quick downward flip of the iron. The rosin flux evaporates quickly from hot solder; hence, it is best to apply fresh solder to each joint rather than carry old solder on the iron.

Preparation of the work is even more important in radio soldering than in other forms be-

cause here we require a good electrical path as well as mechanical strength. Metal terminal lugs should be scraped or sanded until bright, as also should bare wires.

Insulated wire requires special techniques. With push-back insulated hook-up wire, push the insulation back from the end with the thumb and first finger of one hand while holding the wire in the other hand, far enough to expose about  $\frac{3}{4}$  inch of the wire. Since this kind of

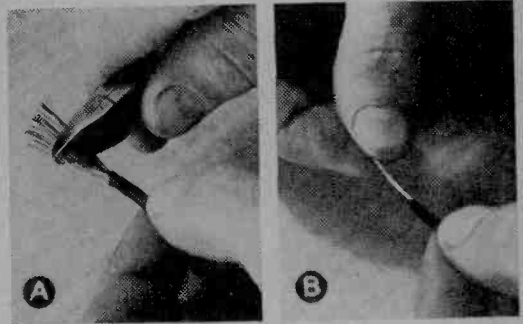

Fig. 19. Clean the spread strands and cut them off to proper length. Then twist the strands back together as shown in A and B, above.

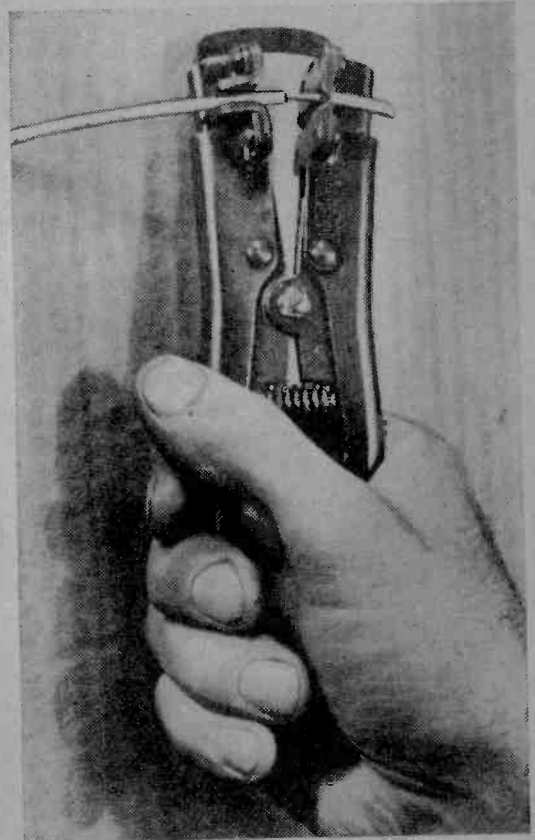

Fig. 20. An insulation stripping tool.



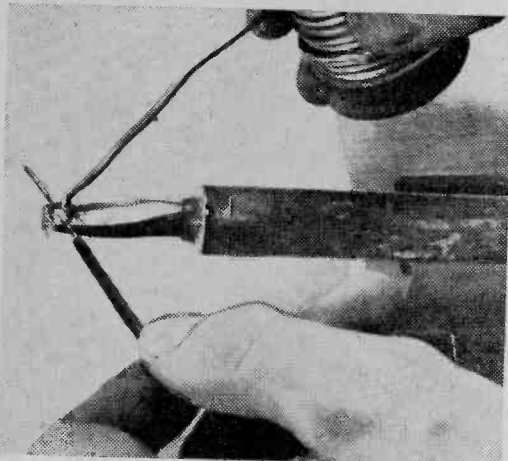

Fig. 21. Tinning the electric wire.

wire is tinned during manufacture, no further preparation is ordinarily needed.

With ordinary insulated wire, the insulation can often be split lengthwise for removal by squeezing with long-nose pliers, Fig. 18. The strips of insulation can then be pulled off with the pliers, and loose threads can be clipped off with side-cutting pliers or a pocket knife. The exposed copper wire should then be scraped lightly with the blade of the knife to remove oxides and dirt.

When insulation cannot be removed by squeezing, hold the wire flat on a workbench or block of wood and rotate it slowly with the fingers while cutting through the outer insulating covering of the wire all around with a sawing motion of a pocket knife held about  $\frac{3}{4}$  inch from the end of the wire. Slide off this covering, then peel off the inner rubber or cotton insulation with your fingers or a knife, being extremely careful not to nick the copper wire. Scrape the exposed wire as before, until bright and clean.

With stranded wire, spread out the strands and scrape, doing this several times so as to expose a different part of each strand each time to the

knife. Then cut off to the proper length and twist back together (Fig. 19). A sharp knife is best for removing insulation, as it can be held tightly to avoid cutting too far and nicking or breaking the copper wire. Even the slightest nick will weaken the wire enough to cause a break eventually at that point if the wire is subject to any vibration or bending. A new tool that strips insulation from any standard wire in one motion is shown in Fig. 20.

Enamelled wire presents problems of its own. Solid enamelled wire can be scraped with a knife or cleaned with fine sandpaper folded over the wire and moved along it. Enamel can easily be burned off with an alcohol burner, however, and this procedure is definitely to be preferred in the case of fine stranded enamelled wire such as that used for antennas. Untwist the strands for about  $1\frac{1}{2}$  inches, spread them out so no wires touch, and hold the spread-out strands just within the tip of the inner cone of flame of the lamp until the wires are red hot for about  $\frac{3}{4}$  inch from the end. Now immerse the heated wires quickly in a pan of alcohol and the enamel will dissolve, leaving a bright, clean copper surface.

In general, untinned wire is best tinned by leaving the heated soldering iron in its holder with the tip facing you, holding the cleaned end of the wire on a flat surface of the soldering iron tip, then applying rosin-flux solder to the wire while sliding and rotating the wire slowly until it is completely tinned (Fig. 21). Shake off the surplus solder.

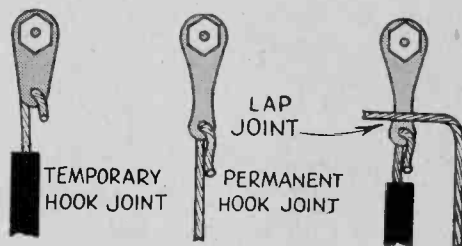

Fig. 22. Three types of lug joints.

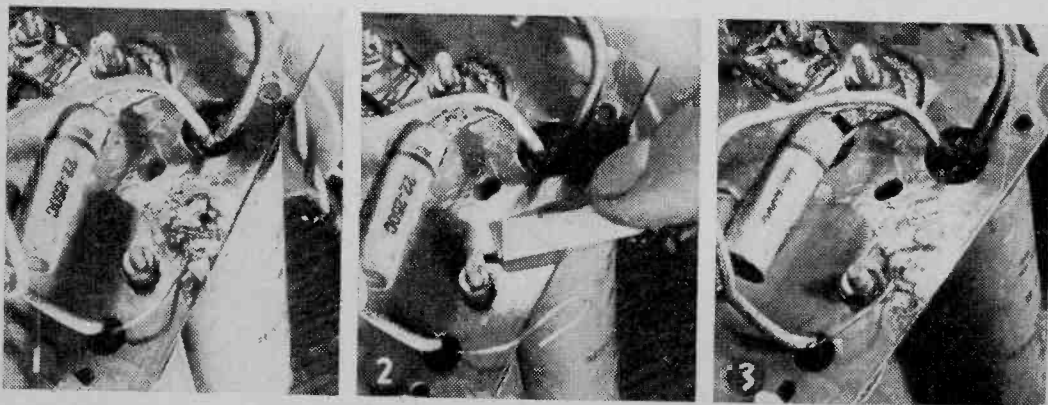
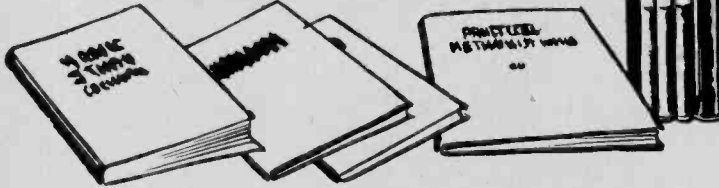

Fig. 23. (1.) Badly soldered ground connection. The iron was too cold, and too much solder was used. (2.) Clean off and try it over. (3.) This is a strongly soldered ground, but there is still too much solder.

# PRACTICAL BOOKS

## FOR HOME STUDY



**STEEL SQUARE.** Complete explanation for using this important tool. Covers various scales, using squares, calculating lengths, laying out rafters, figuring roof spans, runs, rises, pitches, etc. A real "how-to-do-it" book enabling you to learn all standard uses of the steel square. 101 illustrations. \$2.25.

**UNIVERSAL MACHINISTS HANDBOOK.** This book in the fourth edition. Contains 400 charts, tables, graphs, etc. Illustrated data for setup on lathes, milling machines, shapers and drill presses. \$2.00.

**PLASTICS — PROBLEMS AND PROCESSES.** With considerable emphasis on design, it introduces readers to the entire field of plastics without too much technical stress on any particular phase. 215 designs. 352 pages, illustrated. \$3.00.

**CARPENTRY.** This practical 436-page book explains principles of building construction. Including rafters, roofs, floors, walls, studing, girders, partitions, bridging, trusses, etc. How to make all types of joints, how to build concrete forms, how to finish both inside and outside, and hundreds of other important subjects. 541 illustrations. Exceptional value. \$2.50.

**PRACTICAL FURNITURE FINISHING.** Explains how to create original finishes as well as repair old finishes. Covers finishing of all popular hard and soft woods, also fancy veneers, inlays, rare and fancy woods. Includes latest methods for such novelty finishes as blond pickled, frosted, bone white, dusty antique, old world, polychrome, two-tone, etc. 85 illustrations, many in natural color. \$1.25.

**HORNUNG'S HANDBOOK OF DESIGNS AND DEVICES.** This book furnishes a permanent valuable source of valuable information collected by a commercial artist. It discusses the circle; the line; the band; the triangle; the square; the diamond; and the interlacement. These are only a few of the sections in this 218 page book. Price \$3.75.

**INTERNAL COMBUSTION ENGINES.** Covers basic fundamentals of all types of present-day Diesel, airplane and automotive engines, including characteristics, valve timing, thermodynamics, fuels, detonation, carburetion, injection process, spark and compression ignition engines, supercharging, etc. 450 pages. 302 illustrations. \$5.00.

**REFRIGERATION SERVICE MANUAL.** Covers newest developments in household and small commercial refrigeration. Takes up installation, testing, trouble shooting, replacement, repairs, etc.. 300 pages. 138 illustrations and diagrams. \$2.00.

**ARMATURE WINDING.** Explains with 246 illustrations, connecting diagrams and detailed instructions how to wind, test and repair A.C. and D.C. motors and generators. Written especially for home study. \$2.50.

**24 ACTION TOYS.** Complete handbook of toy-making. Covers tools and supplies, transferring design; sawing; fastening parts together; coloring and finishing; and design for making standing, rocking, and wheeling animals including kangaroo, bear, camel, tiger, buffalo. A l s o designs for jumping jacks, acrobats, pecking hens, shimmy walker, bronco buster, etc. Well illustrated. 90c.

**PRACTICAL ELECTRICITY AND HOUSE WIRING.** Discusses basic principles of circuits, wires and insulation, three-wire system, grounding, polarizing, fuses and circuits, wiring methods, planning installations, wiring new houses, installing switches, fixtures, etc., wiring houses after they are built, wiring farm buildings, wiring for motors, AC and DC, single-phase and three-phase, home repairs, etc. 190 pages. 208 illus. \$2.00.

**PRACTICAL COURSE IN MODERN LOCKSMITHING.** Simple descriptions, explanations, and illustrations. Covers the historical background of locksmithing, a glossary of technical terms and trade terms; tools and working equipment; masterkeying, warded and tumbler locks; and safe, vault, and bank locks. \$3.95.

**PRACTICAL COURSE IN HOROLOGY.** Valuable to beginner or professional, this book presents the fundamental of watch construction, repair, and adjustment. Complete coverage of tools and materials. Every trick of the trade is explained in a clear, detailed manner. \$2.75.

**THE HANDBOOK OF KNOTS.** 195 pages pocket-size book by famous knot expert, illustrates and explains 428 knots and ties in detail. These knots are used in 48 different occupations including butchers, divers, farmers, electricians, fishermen, tailors, yachtsmen and trappers. Price \$1.00.

**MIXING OF COLORS AND PAINTS.** Practical information on art of mixing colors and paint for interior decorating, house painting, arts and crafts, color formulas, color cards, furniture, polychrome finish, selecting color schemes, thinners, dryers, etc. 296 pages. \$2.50.

**1,000 WAYS TO MAKE MONEY.** Practical plans for making extra money in spare time or from limited capital. \$1.00.

**INDUSTRIAL ELECTRIC WIRING.** Covers description and analysis of every phase of construction, operation, and maintenance of both AC and DC wirings. More than 100 valuable tables, diagrams, and photographs. Price \$3.00.

**DIESEL FUEL INJECTION SYSTEMS.** Describes the construction, operation, maintenance, and servicing of fuel injection systems used on American Diesel engines. 174 pages, illustrated. \$1.00.

**BOATBUILDING.** Practical handbook designed and written to meet the needs of the builder of all types from rowboats to commercial vessels. Covers the complete processes of wooden boat construction. \$7.50.

**PATENT FUNDAMENTALS.** Demonstrates the principles of true invention, procedure in obtaining patent protection, drafting effective claims, making assignments, issuing licenses. Essential facts about trademarks and copyrights also included. \$2.00.

**2100 NEEDED INVENTIONS.** Source book of practical money-making ideas that are crying to be invented. Special chapters on the art of inventing and how to develop and protect ideas. 252 pages. \$2.50.

**AN OIL BURNER HANDBOOK.** Fields of industrial and domestic oil burners covered in this 250 page book. Useful for mechanic and technician. Diagrams, photographs and tables clarify instructions and explanation. \$2.50.

**KNOTS, SPLICES AND ROPE WORK.** Simple and complete directions for making the most useful and ornamental knots in common use and many other unusual ones. \$1.50.

**SUNSET'S BARBECUE BOOK.** Contains details for building 14 basic types of outdoor barbecues and grills; also a special section of savory recipes and menus. \$1.50.

**HOUSEHOLD MECHANICS.** Almost 150 jobs in woodworking, metal working, painting and finishing in the home, care of electrical appliances, using concrete and plaster, etc. 256 pages. 642 illustrations. \$3.00.

**GENERAL LEATHERCRAFT.** A brief history of leather and kinds of leathercraft. Contains list of tools, equipment needed and list of supply companies. Procedures are given in detail and many designs included. Price \$1.20.

**REVISED LAPIDARY HANDBOOK.** Covers the following: Sawing, gem drilling, bead making, cutting faceted gems, the optics of brilliants, artificial coloring of agates, soft carving with steel tools, carving a n d engraving, hard materials, bracelets and rings. Price \$3.00.

### USE THIS HANDY COUPON NOW

SCIENCE AND MECHANICS,  
450 East Ohio Street, Dept. R-2, Chicago 11, Ill.

Enclosed is \$..... for which send me the following books,  
all charges prepaid.

NAME .....

STREET AND NUMBER .....

CITY .....

ZONE .....

STATE .....

If you prefer, books will be sent C. O. D., plus postage in U. S. only.

For proper tinning of stranded wire, untwist the cleaned strands for about 1/2 inch from the end and spread out the strands fanwise. Tin the wires by applying solder to one side while heating the strands with the soldering iron from the other side, and shake off surplus solder while it is still molten or tap the strands with the iron. After the wire has cooled, twist the strands together again. Difficulty in tinning stranded wire means that additional careful scraping or sanding of individual wires is necessary. With new and fairly clean stranded wire, it is sometimes possible to tin the wire without untwisting, but there is the risk that the inner strands will not be thoroughly tinned, and the wire may be too stiff to bend when forming a joint.

When a wire is to be attached to a soldering lug, the lug must also be tinned. This calls for essentially the same technique as for solid wires—careful scraping, then heating from one side while rubbing the other side with solder. Lugs are extensively used for making connections to a metal chassis, because a soldered connection to a flat metal surface is usually messy in appearance and may not have adequate mechanical strength. Lugs are also used extensively on terminals of radio parts.

When a soldering lug is being tinned, the hole in its small end usually fills up with solder. This hole must be opened to permit looping the connecting wire through the hole. Brushing out the solder while molten is bad practice because it scatters molten solder in all directions and may

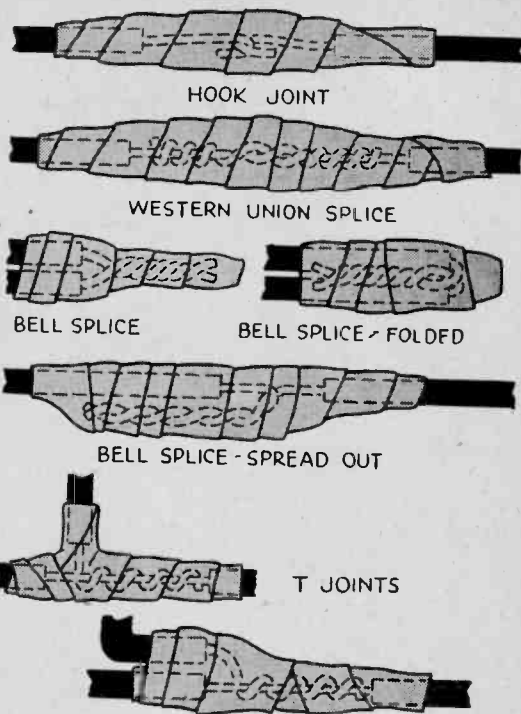

Fig. 25. Seven methods of taping joints.

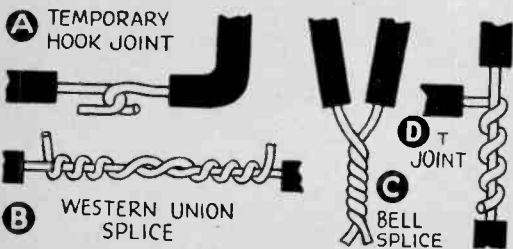

Fig. 24. Four types of wire joints.

cause short circuits. Instead, wipe surplus solder from the soldering iron tip with a cloth; then use the iron to pick up surplus solder from the lug. Wipe this from the iron, and again apply the iron to the lug, until the solder in the hole has been picked up. Sometimes the solder can be poked out of the hole by inserting the cleaned tip of the iron in the hole. Remember—the less solder on the iron, the more solder you can pick up with it. It should be mentioned that some servicemen do not bother to remove surplus solder from a lug; they simply apply the soldering iron to the lug to melt the solder; then poke the wire through the hole, and bend the wire to the desired shape after the solder has hardened.

The Types of Joints

The three types of joints most often used in

connecting a wire to a soldering lug are temporary hook joints, permanent hook joints, and lap joints (Fig. 22). To make a temporary hook joint such as is required when it may be desirable to remove the wire later without too much trouble, bend the cleaned and tinned end of the wire into a hook with long-nose pliers, and insert this hook in the hole in the lug. If there is any tendency for the wire to fall out, the hook may be closed a bit more after insertion, but should not be pinched together. Now apply the heated soldering iron to the top of the lug and on one side of the wire, and apply solder to the other side of the wire and to the lug, but not directly to the soldering iron. Use enough solder to fill the gap between the lug and the hooked wire; then remove the iron but do not move the wire until the solder has hardened.

The permanent hook joint is made in the same manner except that the hook is squeezed tightly together with long-nose pliers after insertion. It is always more satisfactory, and should be used whenever there is a possibility that the joint may be in use for some time because it provides much-needed mechanical strength as well as good electrical contact.

A temporary lap joint is made by simply holding the straight end of the tinned wire over the tinned lug, pressing the heated soldering iron over rosin-core solder so some solder will adhere to the lower face of the tip, then applying the soldering iron to the top of the wire so as to fuse together the solder on the wire and on the lug.

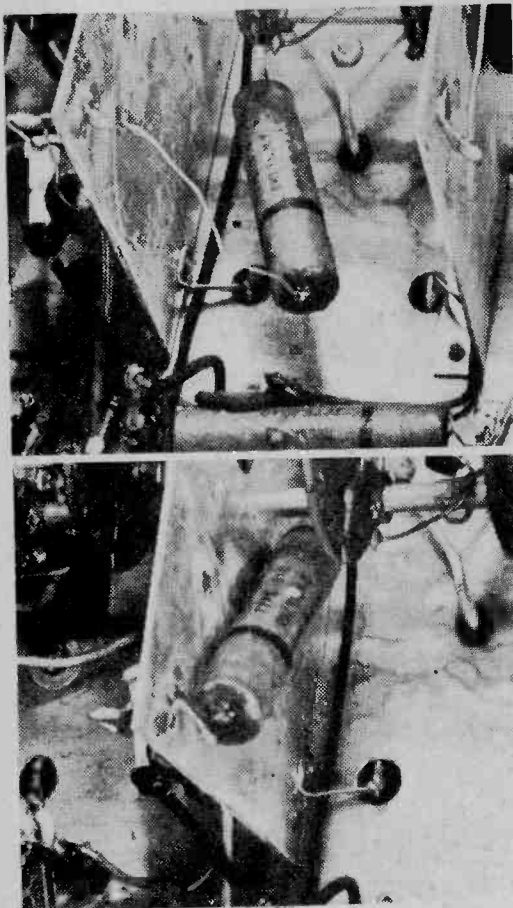

Fig. 26. Never let any parts subject to vibration hang from a soldered joint as shown in top view. Pull them up snugly as shown in the lower photo.

Remove the iron as soon as fusion occurs, but continue holding the wire rigid until the solder has hardened. If the hand is rested against some part of the chassis, it is much easier to hold the wire steady for the short cooling period required.

Whenever possible, insulation should be kept at least  $\frac{1}{8}$  inch away from the lug when the wire is in soldering position, to avoid burning the insulation. With push-back wire, the insulation can be pushed right up to the lug after the joint is completed. At this time, the joint can also be dressed by arranging the wires neatly, straightening out kinks, and nipping off surplus wire projecting from the joint.

### Joints for Wire to Wire

A number of different types of joints are in general use for soldering two wires together (Fig. 24). The only temporary joint is the hook joint, made by forming a hook in the end of each wire, linking together the hooks, then applying the heated soldering iron and solder on opposite sides. If the wires are spread apart before being hooked together, the spring tension in them will prevent

the wires from falling apart before and during soldering. A permanent hook joint is made in the same way except that the hooks are squeezed together tightly to form a semi-rigid joint.

The Western Union splice (Fig. 24-b) is preferred by radio men when mechanical strength is required, as in antenna systems. To make it, clean each wire for at least  $1\frac{1}{2}$  inches from the end, grasp one wire in each hand and cross the bared ends, then twist each wire in turn around the other, but in opposite directions. Keep the turns of wire far enough apart so solder can flow between the turns. The twisting is done with the fingers, leaving about  $\frac{1}{4}$  inch of wire untwisted at each end and cutting this off with side-cutting pliers. The joint is then straightened with the fingers, and solder is applied just as for hook joints.

A permanent Bell splice (Fig. 24-c) is somewhat easier to make, particularly in tight locations, but has little mechanical strength insofar as pulling is concerned. Simply cross the bared ends while holding both wires in one hand, and twist the ends together with the fingers of the other hand.

To connect one wire to some point other than the end of another wire, use the permanent T type joint (Fig. 24-d). Expose about one inch of wire at the desired point of connection, being extremely careful not to nick the wire outside the proposed location of the joint (nicks in the joint region will be bridged by solder). Now simply wind the end of the other wire around this wire, spacing the turns slightly. Trim off the end of the wire, then solder as before. Be sure that solder flows between the turns or twists of the wire. Methods of taping the various kinds of joints are shown in Fig. 25.

### Unsoldering Old Joints

Replacement of a defective part in electronic or radio equipment generally requires that joints for the old part be first unsoldered and the old part removed. In a few cases this simply involves applying a heated soldering iron to a joint while pulling on the wire with fingers or pliers, but with properly made joints a definite technique is required for speedy unsoldering.

First, the solder on the old joint must be melted. Mere application of the hot iron will not always do this fast enough because of the accumulation of heat-resisting oxides and dirt on the old solder. Here a little trick is well worth remembering—apply a bit of fresh rosin-core solder between the iron and the joint. This aids in transfer of heat from the iron to the joint and at the same time the rosin flux cuts through the layer of dirt. Sliding the soldering iron back and forth over the joint helps to cut through the dirt.

Often the hook in a joint can be opened with long-nose pliers while the solder is molten, in which case the wire can be easily pulled out of the hole in the lug. For stubborn joints, melt the solder as above, then remove the iron and wiggle the wire vigorously while the solder is

cooling. Spread apart the hook as much as possible now, then repeat the heating, wiggling and spreading procedure until the wire is separated from the lug. Surplus solder is then lifted off with the cleaned heated soldering iron, in preparation for connecting the new wire.

When connecting radio parts having self-supporting leads, such as small condensers and resistors, bending of the leads to their proper shapes and shortening of the leads when excessively long are important steps (See Fig. 26). Do not intentionally make sharp-cornered bends with pliers, as this may weaken the wire. Make bends with fingers, using pliers only for forming hooks in the ends of the wires. Start bends at least 1/4 inch away from the body of a resistor or condenser. Additional bending is usually required after the joints have been soldered, to keep bare wires away from the chassis or from other bare leads or terminals.

If there is any possibility of an exposed soldered joint coming in contact with other wires, the joint should be taped. A special narrow type of friction tape is made especially for radio work; being only 3/8 inch wide, it can more readily be wrapped around a small joint. Cover exposed wires with at least two thicknesses of the tape, allowing the tape to cover adjoining insulation for about 1/2 inch on each side of the joint.

### Requirements of a Good Soldered Joint

If you readily understand and follow each of the following requirements for making a good soldered joint, you should have no difficulty in making a professional looking job every time.

1. Have the soldering iron at the correct temperature.
2. Keep the iron clean and well tinned.
3. Use an iron of the correct size.
4. Use only rosin-core solder.
5. Clean your work thoroughly before attempting to solder.
6. Make good mechanical contact between parts to be soldered.
7. Tin each part separately if originally untinned.
8. Apply the solder to the part, not to the soldering iron.
9. Do not move the joint until the solder hardens.

### For Dark Corners

• Trying to use a screw driver in a dark space can be very perplexing. A small pocket flashlight of the "fountainpen type" taped to the shank of the screw driver not only illuminates the work effectively, but leaves one hand free. Use electrician's, adhesive, or Scotch tape.

RONALD EYRICH

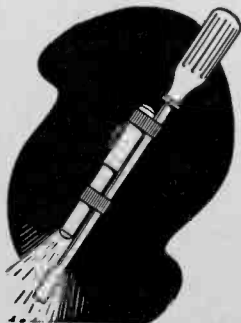

# American Beauty

*dependable*

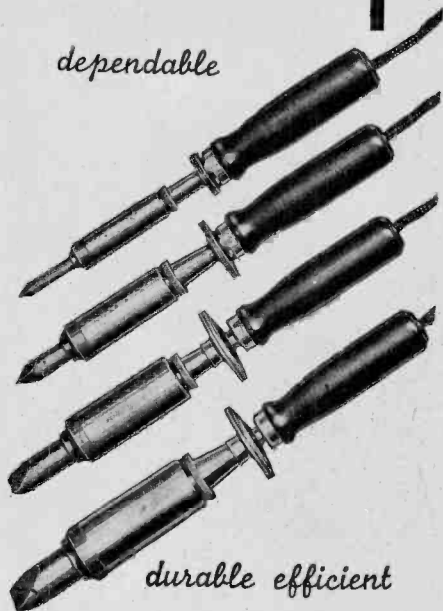

*durable efficient*

## ELECTRIC SOLDERING IRONS

are sturdily built for the hard usage of industrial service. Have plug type tips and are constructed on the unit system with each vital part, such as heating element, easily removable and replaceable. In 5 sizes, from 50 watts to 550 watts.

## TEMPERATURE REGULATING STAND

This is a thermostatically-controlled device for the regulation of the temperature of an electric soldering iron. When placed on and connected to this stand, iron may be maintained at working temperature or through adjustment on bottom of stand at low or warm temperature.

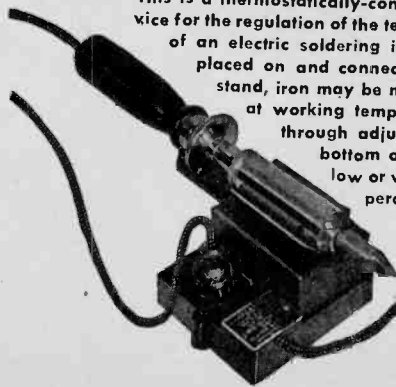

For descriptive literature write

**AMERICAN ELECTRICAL HEATER CO.**  
DETROIT 2, MICH., U. S. A.



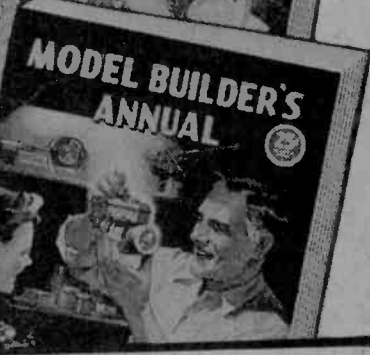

# BIG HANDBOOKS

Your Choice Only 25c Each

### CRAFTWORK

Interesting and profitable hobbycraft projects which may be made with simple tools. Over 30 projects including shell craft, hand-painted textiles, plastic gem boxes, whittling, weaving, cutting of gems, leathercraft, rubber molds, etc. Latest edition 128 pages, 25c.

### TOYS AND GAMES YOU CAN MAKE

Contains detailed plans and instructions for building 51 toys, games and puzzles that will thrill any child. Includes toy helicopter, hobby horse, toy jeep, sliding doll, mechanical acrobat, doll carriage, doll furniture, archery set. Latest edition, 160 pages, 25c.

### BOAT BUILDERS ANNUAL

Complete collection of plans and instructions for building 28 different boats—from an 8-ft. pram to a 24-ft. motor sloop. You will find plans for a row boat, canoe, cabin cruiser, sailboat, sloop, hydroplane, portable boat, folding boat, sea skiff, trailer boat, dingy, bicycle boat, etc. Terrific value. Latest edition, 25c.

### HOME OWNERS ANNUAL

Packed with helpful ideas, plans, and suggestions on home planning, remodeling and repairing. One of America's foremost architects, Paul T. Haagan, gives plans for 9 small homes, modest in cost, yet having the advantages of more expensive homes. There's a special section on modernizing the kitchen, what to do about dampness and moisture in the basement, how to install a summer cooling system for \$60.00, 14 attractive bird houses, how to build an outdoor grill to entertain your friends, and many, many, many other ideas. Latest edition, 25c.

### MODEL BUILDERS ANNUAL

Here's a handbook every model engineer will want. It brings plans and instructions for building a home made furnace to melt metals, how to make your own patterns and mold your own castings. Models include a Coast Guard Motor Life Boat, Twin Cylinder Racing Gas Engine, Oscillating Steam Engine, Centrifugal Pump, 1/8 Hp. Gas Engine, Radio Control for Models, Square Rigger, etc. Latest edition, 25c.

## Build It Yourself

A treasure house of craft ideas. In fact, you'll be thrilled with the 72 projects given in this handbook. Here are a few: magazine rack, dirt track racer, Early American Furniture, cement mixer, baby's crib, cabin trailer, record player, utility boat, metalcraft, tool cabinet, colorprint projector, centrifugal casting of plastics, humidor, spinning wheel, etc. Latest edition, 160 pages

Only **35c**



-----USE THIS HANDY ORDER FORM-----

SCIENCE AND MECHANICS MAGAZINE  
450 East Ohio St., Dept. R-5, Chicago 11, Ill.

Enclosed is \$..... for which send me the following:

<input type="checkbox"/> Craftwork.....25c	<input type="checkbox"/> Home Owner's Annual.....25c
<input type="checkbox"/> Toys and Games You Can Make.....25c	<input type="checkbox"/> Model Builder's Annual.....25c
<input type="checkbox"/> Boat Builder's Annual.....25c	<input type="checkbox"/> Build It Yourself.....35c

NAME .....

ADDRESS .....

CITY.....ZONE.....STATE.....



# What's cooking in Radio?

LOTS OF THINGS. There's television—FM—facsimile—radio telephony. All fields with lots of opportunities—for the trained man.

Do you have the training you'll need to cash in on these fast-growing fields? You can get that training—

at home in your spare time—from I. C. S. Practical, thorough training that has helped thousands like you.

Look at the coupon below. Select the course that interests you most. And mail that coupon *today!* The future won't wait!

## INTERNATIONAL CORRESPONDENCE SCHOOLS



BOX 6667-N, SCRANTON 9, PENNA.

Without cost or obligation, please send me full particulars about the course BEFORE which I have marked X:

- |  |   |
|--|---|
| <input type="checkbox"/> ELECTRONICS           | <input type="checkbox"/> ELECTRICAL DRAFTING      |
| <input type="checkbox"/> PRACTICAL TELEPHONY   | <input type="checkbox"/> ELECTRICAL ENGINEERING   |
| <input type="checkbox"/> RADIO, GENERAL        | <input type="checkbox"/> ELECTRIC LIGHT AND POWER |
| <input type="checkbox"/> RADIO OPERATING       | <input type="checkbox"/> LIGHTING TECHNICIAN      |
| <input type="checkbox"/> RADIO SERVICING       | <input type="checkbox"/> PRACTICAL ELECTRICIAN    |
| <input type="checkbox"/> TELEGRAPH ENGINEERING |   |

Name \_\_\_\_\_ Age \_\_\_\_\_ Home Address \_\_\_\_\_

City \_\_\_\_\_ State \_\_\_\_\_ Working Hours \_\_\_\_\_ A. M. to \_\_\_\_\_ P. M.

Present Position \_\_\_\_\_ Employed by \_\_\_\_\_

Length of Service in World War II \_\_\_\_\_

Enrollment under G.I. Bill approved for World War II Veterans. Special tuition rates to members of the Armed Forces. Canadian residents send coupon to International Correspondence Schools Canadian, Ltd., Montreal, Canada.

THESE MEN ARE GETTING PRACTICAL TRAINING

# IN ELECTRICITY

*On Real:*



**A.C. and D.C. MOTORS  
GENERATORS  
SWITCHBOARDS  
CONTROLLERS  
WIRING JOBS  
APPLIANCES  
ELECTRONIC UNITS**

*(Shown at left—Instructor demonstrating latest type of Test Unit for checking the efficiency of a Motor.)*

# AND RADIO-TELEVISION

*On Real:*

**TELEVISION SETS  
RADIO RECEIVERS  
F.M. (Frequency Modulation)  
RECORD CHANGERS  
AUTO RADIOS  
AIRPLANE RADIOS  
PUBLIC ADDRESS Systems**

*(Right—Instructor explaining operation of 20-inch Cathode Ray tube used in Daimont Television Set.)*



**Just Like YOU Can Get in the Great SHOPS of COYNE**

Prepare NOW for a real future the quick, practical way. Come to the Great Shops of COYNE in Chicago. Largest and best equipped school of its kind—now celebrating our 50th Anniversary. GI approved. Finance plan for non-veterans. Mail coupon.

**NOT "HOME-STUDY" COURSES!** At Coyne you learn on real, full-size equipment. Trained instructors show you how, then you do typical jobs yourself. We don't teach by mail.

**CLIP COUPON NOW** for big new illustrated Coyne book on either ELECTRICITY or RADIO-TELEVISION or both. No obligation; no salesman will call. Get the facts now!

**B. W. COOKE, Pres.  
ELECTRICAL &  
RADIO SCHOOL,  
500 S. Paulina St., Dept. 69-91H  
Chicago 12, Ill.**

**COYNE**

**Mail Coupon for  
FREE BOOK!**



**B. W. COOKE, President  
COYNE ELECTRICAL &  
RADIO SCHOOL, Dept. 69-91H  
500 S. Paulina St., Chicago 12, Ill.**

Send FREE, the book checked below, and details of your training offer. This does not obligate me and no salesman will call.

ELECTRICITY       RADIO-TELEVISION

NAME *B. W. COOKE*

ADDRESS .....

CITY ..... STATE *Ill.*

